

AIRE

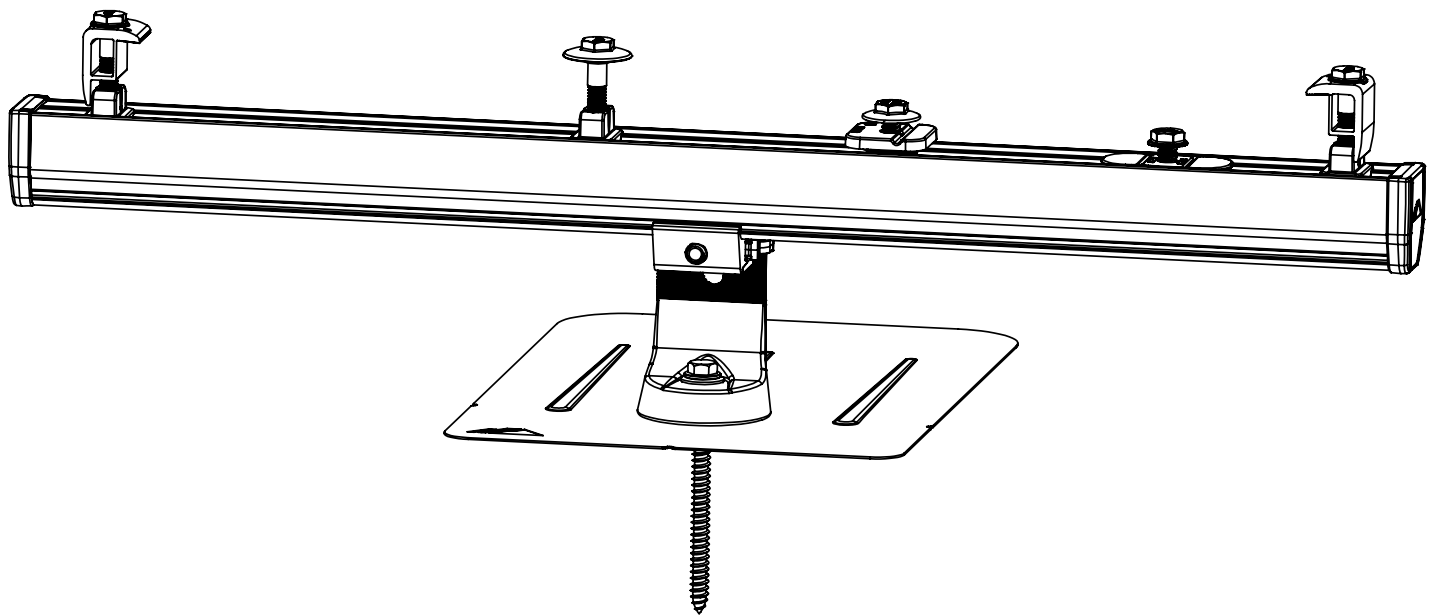

CONTENTS

DISCLAIMER	1
RATINGS	2
MARKINGS	2
ATTACHMENTS	3
COMPONENTS	4
1. PLACE ATTACHMENTS	5
2. PLACE RAILS	5
3. SECURE AIRE LUG	6
4. SECURE MODULES	6
SECURE MODULES (AIRE LOCK STEALTH)	7
EXPANSION JOINTS	8
ELECTRICAL DIAGRAM	9
COMPOSITION SHINGLE	10-12
TILE	12-13
ADDITIONAL ROOF TYPES	14
CABLE TRAY SYSTEM	15
AIRE CAP	15
AIRE CLIP	15
AIRE MLPE MOUNT	16
CONTOUR TRIM	17
MODULE COMPATIBILITY	18-24

DISCLAIMER

This manual describes proper installation procedures and provides necessary standards required for product reliability. Warranty details are [available on the website](#). All installers must thoroughly read this manual and have a clear understanding of the installation procedures prior to installation. Failure to follow these guidelines may result in property damage, bodily injury or even death.

IT IS THE INSTALLER'S RESPONSIBILITY TO:

- Ensure safe installation of all electrical aspects of the array. All electrical installation and procedures should be conducted by a licensed and bonded electrician or solar contractor. All work must comply with national, state and local installation procedures, product and safety standards.
- Comply with all applicable local or national building and fire codes, including any that may supersede this manual.
- Ensure all products are appropriate for the installation, environment, and array under the site's loading conditions.
- Use only IronRidge parts or parts recommended by IronRidge; substituting parts may void any applicable warranty.
- Review the [Design Assistant](#) and [Certification Letters](#) to confirm design specifications.
- Ensure provided information is accurate. Issues resulting from inaccurate information are the installer's responsibility.
- Ensure bare copper grounding wire does not contact aluminum and zinc-plated steel components, to prevent risk of galvanic corrosion.
- If loose components or loose fasteners are found during periodic inspection, re-tighten immediately. Any components showing signs of corrosion or damage that compromise safety shall be replaced immediately.
- Provide an appropriate method of direct-to-earth grounding according to the latest edition of the National Electrical Code, including NEC 250: Grounding and Bonding, and NEC 690: Solar Photovoltaic Systems.
- Disconnect AC power before servicing or removing modules, AC modules, microinverters and power optimizers.
- Review module and any 3rd party manufacturer's documentation for compatibility and compliance with warranty terms and conditions.
- Aire rails shall not be used as scaffolding, a roof jack, or any form of an anchoring point for roof personnel.
- Ensure that the roof is in good condition prior to installing any IronRidge components.

RATINGS

UL 2703 LISTED



Conforms to UL STD 2703 Standard for Safety First Edition: Mounting Systems, Mounting Devices, Clamping/Retention Devices, and Ground Lugs for Use with Flat-Plate Photovoltaic Modules and Panels

- Scope of Evaluation includes bonding, grounding, mechanical loading, and fire classification
- Max Overcurrent Protective Device (OCPD) Rating: 40A
- Max Module Size: 30.5 ft²
- Module Orientation: Portrait or Landscape
- System Design Load Rating: 10 PSF downward, 5 PSF upward, 5 PSF lateral
- Actual system structural capacity including spans and cantilevers are defined by PE stamped [certification letters](#)

CLASS A SYSTEM FIRE RATING PER UL 2703

- Any Roof Slope with Module Types 1, 2, 3, 13, 19, 25, 29 and 38: Allowed with any roof slope. Any module-to-roof gap is permitted, with no perimeter guarding required.
- Module Types 4 and 5: Allowed with Steep Slope Roofs ($\geq 9.5^\circ$). Any module-to-roof gap is permitted, low edge guarding (trim) required
- Class A rated PV systems can be installed on Class A, B, and C roofs without affecting the roof fire rating

CLASS B SYSTEM FIRE RATING PER UL 2703

- Module Types 4 and 5: Allowed with Steep Slope Roofs ($\geq 9.5^\circ$). Any module-to-roof gap is permitted, with no perimeter guarding required

CERTIFIED TO CSA STD TIL NO. A-40 PHOTOVOLTAIC MODULE RACKING SYSTEMS

- Load Rating: 2400 PA [50 PSF]

AIRE RAILS CERTIFIED TO CSA STD C22.2 #126.1 METAL CABLE TRAY SYSTEMS

- Conforms to NEMA VE1
- Rail Internal Cross Section: 2in²
- Material: Aluminum
- Nonventilated / non ventilé

WATER SEAL RATINGS:

- UL 441 and TAS100(A) (Flashfoot2, L-Mount, Flashvue, All Tile Hook, Knockout Tile, Halo UltraGrip)
- Tested and evaluated without sealant
- Any roofing manufacturer approved sealant is allowed.
- Ratings applicable for steep roof slopes 2:12 and above.

UL 2703A Ratings:

- Conforms to UL SUBJECT 2703A - Halo UltraGrip and BUG
- Steep Slope Ratings applicable for Asphalt Shingle roofs with slopes 2:12 and up
- Low Slope Ratings applicable for Roll Roofing (Rolled Comp) roofs with slopes 1:12 and up
- Low Slope Ratings applicable for Modified Bitumen (Mod-Bit) roofs with slopes 1/4:12 and up
- Installer must verify roof slope prior to installing HUG or BUG to validate applicable roof types

STRUCTURAL CERTIFICATION

- Designed and Certified for Compliance with the International Building Code & ASCE/SEI-7

FLORIDA PRODUCT APPROVAL #FL41593

- Approved for installation both inside and outside High Velocity Hurricane Zones (HVHZ)
- Additional details and full list of approved components can be found [here](#)

MARKINGS

Product markings are located on the Aire Dock Bolt.

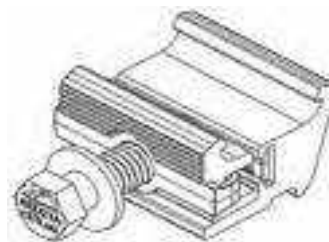

ATTACHMENTS

PRE-INSTALLATION

- Verify module compatibility. See [Page 19](#) for info.

TOOLS REQUIRED

- Cordless Drill (non-impact)
- Impact Driver (for lag bolts)
- Torque Wrench (0-250 in-lbs)
- 1/2" Socket
- 7/16" Socket
- 7/32" Drill Bit
- 1/8" Drill Bit
- 5/8" Socket
- 1/4" Drill Bit
- T30 Torx Bit
- Channel Lock Pliers
- #3 Phillips Bit
- 3/16" Hex Bit

BONDING HARDWARE TORQUE VALUES

Please refer to each attachment's individual section for full details on all torque values and instructions.

- 3/8" Aire Dock Bolt (1/2" Socket): 250 in-lbs
- All Tile Hook Carriage Bolts (1/2" Socket): 132 in-lbs
- Lynx Set Screw (3/16" Hex Drive): 150 in-lbs
- Lynx Flange Nut (1/2" Socket): 150 in-lbs

ATTACHMENTS

COMPOSITION SHINGLE



FlashFoot2

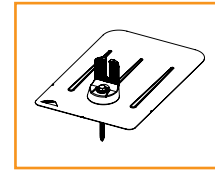

FlashVue

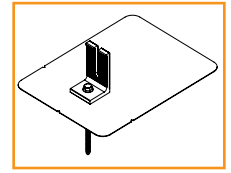

QM L-Mount

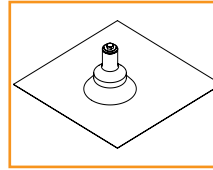

QM QBase Comp

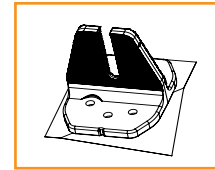

HUG
(Halo UltraGrip)

TILE

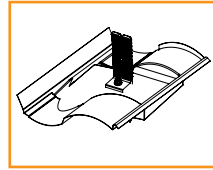

Knockout Tile

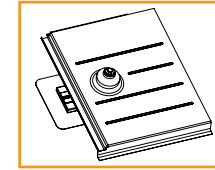

QM Tile Replacement

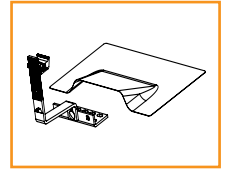

Aire All Tile Hook and
Flashing (optional)

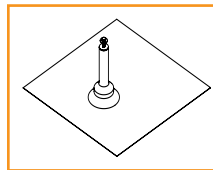

QM QBase Universal
Tile

ADDITIONAL ROOF TYPES

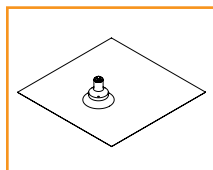

QM QBase Shake -
Slate - Metal Shingle

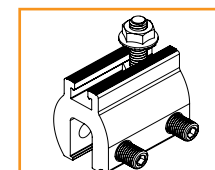

QM Lynx Metal Roof
Attachment

COMPONENTS

PRE-INSTALLATION

- Verify module compatibility. See [Page 19](#) for info.

TOOLS REQUIRED

- Cordless Drill (non-impact) □ 1/2" Socket
- Torque Wrench (0-250 in-lbs) □ T30 Torx Bit

TORQUE SPECIFICATIONS

Please refer to each attachment's individual section for full details on all torque values and instructions.

- Aire Tie Bolt (1/2" Socket): 144 in-lbs
- Aire Lock Mid (1/2" Socket): 144 in-lbs
- Aire Lock End (1/2" Socket): 144 in-lbs
- Aire Lock Stealth (1/2" Socket): 144 in-lbs
- Aire Dock (1/2" Socket): 250 in-lbs
- Aire Lug (1/2" Socket): 144 in-lbs
- Aire MLPE Mount (1/2" Socket): 144 in-lbs
- Contour Clamp (T-30 Torx Bit): 80 in-lbs
- Module Grounding Lug
 - Grounding Nut (7/16" Socket): 60 in-lbs
 - Grounding Lug Terminal Screws (7/16" Socket): 20 in-lbs

COMPONENTS

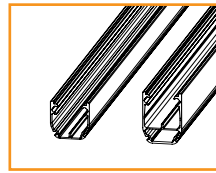

Aire A1 and A2 Rails

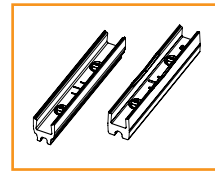

Aire A1 and A2 Ties

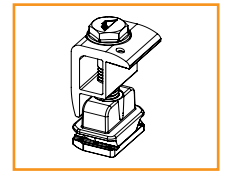

Aire Lock End

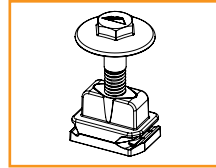

Aire Lock Mid
30-40mm

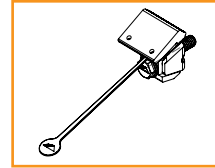

Aire Lock Stealth

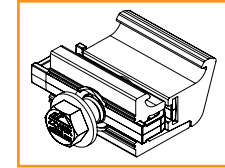

Aire Dock

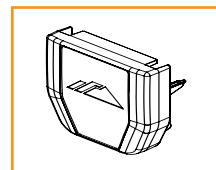

Aire A1 and A2 Caps

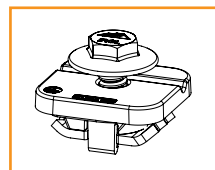

Aire Lug

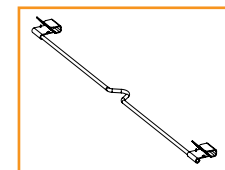

8" Bonding Jumper
Single Use Only

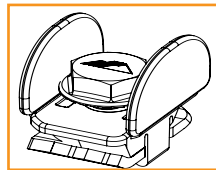

Aire MLPE Mount

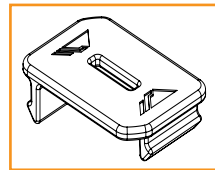

Aire Clip

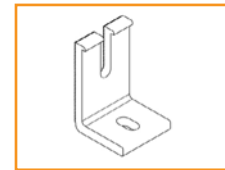

L-Foot

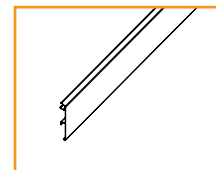

Contour Trim

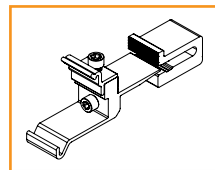

Contour Clamp

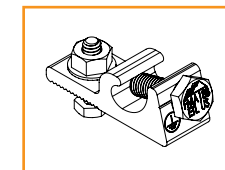

Module Grounding
Lug

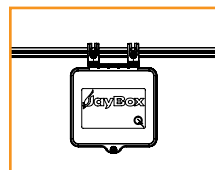

JAYBOX

1. PLACE ATTACHMENTS

The general installation method for attachments is to locate a rafter, drill a pilot hole and install the attachment. When using approved third party attachments, refer to that manufacturer's install instructions.

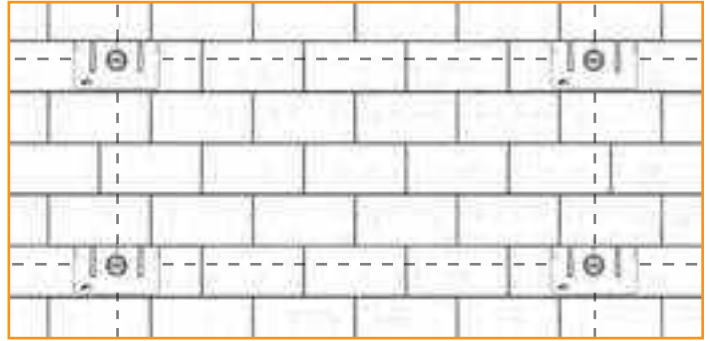

Tested or evaluated third-party roof attachments:

- [S-5! Standing Seam Metal Roof Clamps](#) - Certification of metal roof clamps includes bonding to both painted and galvalume metal roofs. Follow all instructions and installation practices outlined by S-5! in their [Resources Page](#).
- [EcoFasten Green Fasten GF-1 Anchors](#)

2. PLACE RAILS

A. Connect Aire Tie

Insert Aire Tie 4" into first Rail and secure with pre-assembled Splice Bolt. Torque to **144 in-lbs**. Slide second Rail over Aire Tie and secure to second Rail with second Splice Bolt.

- Aire Tie may be installed in any location between two attachments.
- Rows of continuous Rail exceeding 60 feet must use Expansion Joints.

B. Place Aire Dock on Roof Attachments

Place Aire Dock on Roof Attachments, preparing Aire Dock to attach to Rail. Do not torque until after Rail has been installed.

- Aire dock can be installed on the upslope or downslope side of a roof attachment.
- For steeper roof pitches greater than 8/12 (33 degs) It is recommended that Aire dock be installed on the upslope side.
- Aire Lock Mid and Aire Dock must be installed 1" away from where two Rails join together.

C. Attach Rails

Drop Rail into Aire Dock, level Rail to desired height and torque to **250 in-lbs**. Ensure Rail is properly engaged in Dock after torquing.

- Rail can face either upslope or downslope on roof.
- When using attachments with longer slots, do not install Rail lower than the top of the L-Foot to avoid damage to modules.

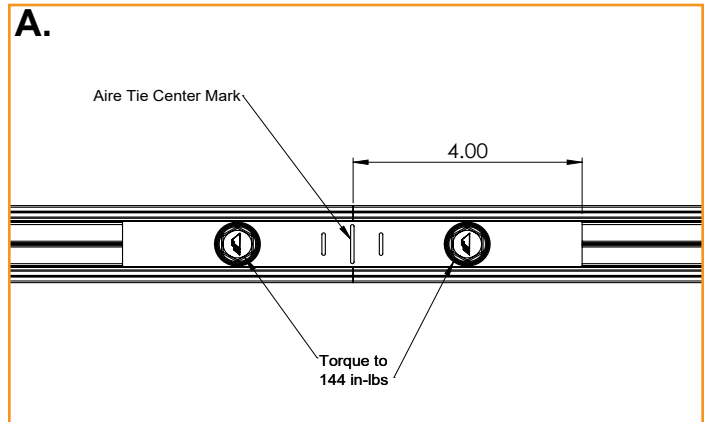

B.

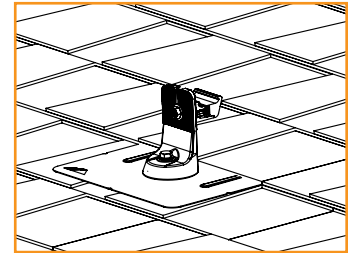
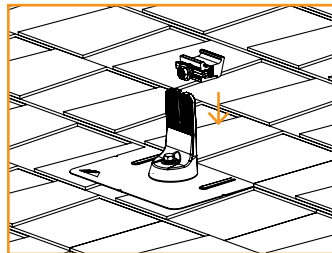

C.

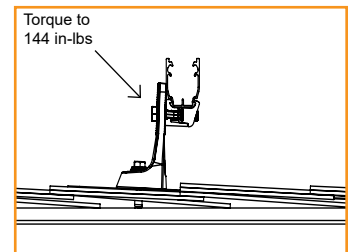
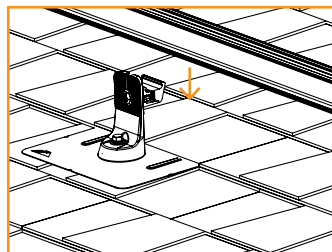

3. SECURE AIRE LUG

Aire Lug

Insert Aire Lug into Rail and twist quarter-turn clockwise to engage with Rail. Install a 10-6 AWG solid copper or stranded grounding wire. Torque pre-assembled Terminal Bolt to **144 in-lbs** securing wire to Lug and Lug to Rail.

- Aire Lugs are intended for use with one solid or stranded copper wire, conductor size 10-6 AWG.
- Aire Lugs can be installed anywhere along the Rail.
- Ensure bare copper grounding wire does not contact aluminum and zinc-plated steel components, to prevent risk of galvanic corrosion.

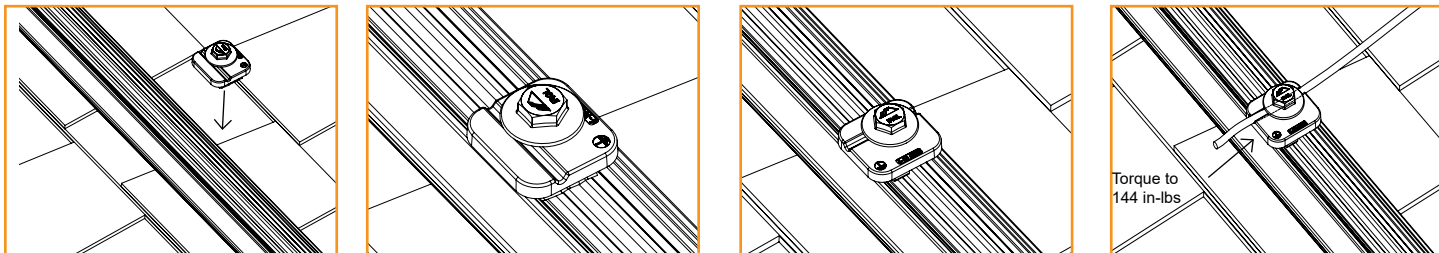

4. SECURE MODULES

A. SECURE FIRST AIRE LOCK END CLAMP

Place first module in position on Rails, a minimum of 1" from Rail ends. Rotate clamp quarter-turn into place in Rail. Fasten module to Rail ensuring clamp is fully engaged with module frame. Torque to **144 in-lbs**.

- Ensure Rails are square before placing modules
- Hold Aire Lock End while torquing to prevent rotation.
- If using Aire Lock Stealth, see [Aire Lock Stealth section](#).

A.

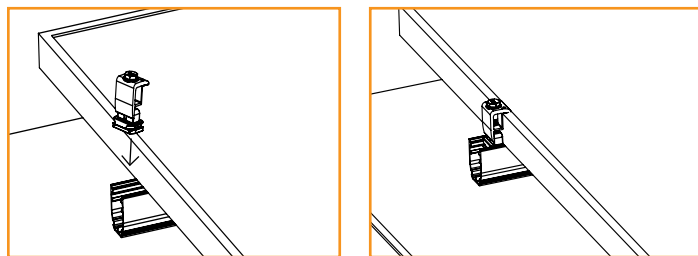

B. SECURE NEXT MODULES

Rotate Aire Lock Mid clamp quarter-turn into each Rail, slide them into place flush against the first module. Slide second module against Aire Lock Mids, torque to **144 in-lbs**. Repeat for each following module.

B.

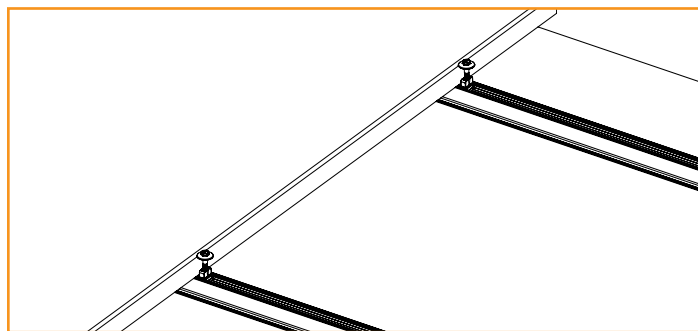

C. SECURE LAST AIRE END CLAMP

Place last module in position on Rails, a minimum of 1" from Rail ends. Rotate clamp quarter-turn into place in Rail. Fasten module to Rail ensuring clamp is fully engaged with module frame. Torque to **144 in-lbs**.

Repeat all steps for each following row of modules, leaving a minimum of 1/2" gap between rows.

C.

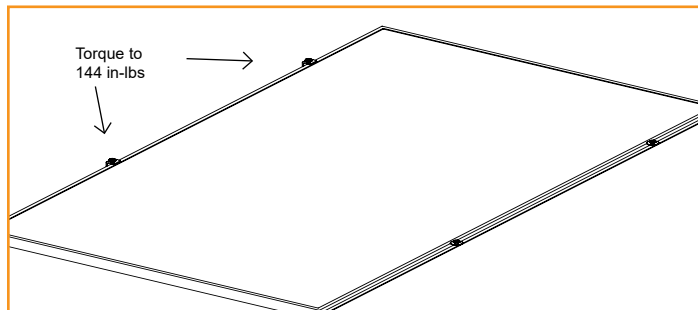

AIRE LOCK STEALTH CLAMP

A. Slide Aire Lock Stealth into Rail

Slide Aire Lock Stealth into Rail channel far enough to clear module frame.

B. Place module

Place module on rail over clamp, pull clamp onto module frame (towards Rail end) by pulling on the clamp tether. Pull until clamp can no longer move any further and is fully engaged with module frame bottom flange.

C. Secure Aire Lock Stealth

Secure the clamp to module frame and Rail by torquing the Aire Lock Stealth bolt. Pull the clamp tether as you torque the clamp bolt into place, ensuring the clamp remains in position and is fully engaged with module frame bottom flange. Torque to **144 in-lbs**.

Tuck the clamp tether into the rail and out of the way by bending it to fit inside the rail channel.

A.

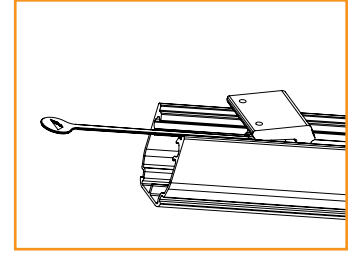
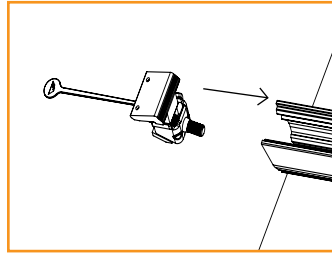

B.

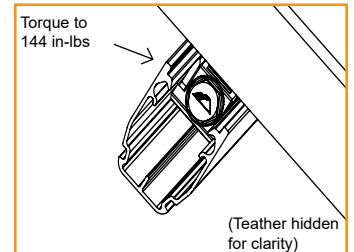
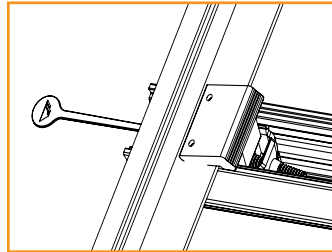

C.

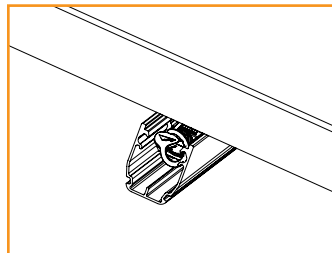

FRAME COMPATIBILITY

Aire Lock Stealth has been tested or evaluated with all modules listed in the Module Compatibility section having frames within the referenced dimensions. Be sure the specific module being used meets the dimension requirements.

- Flange Thickness (X): 1-5 mm
- Useable Bottom Flange Length (Y): 8-35 mm

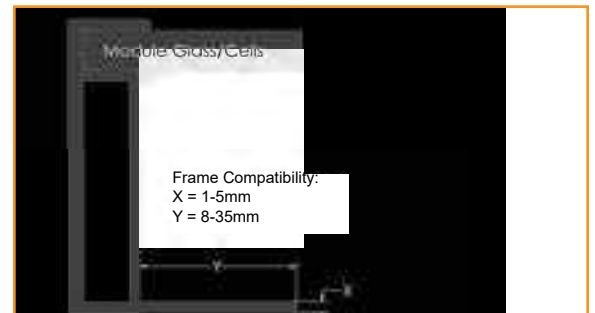

EXPANSION JOINTS

Expansion Joints are required every 60' of continuous Rail to allow for thermal expansion and contraction of the system.

A. Insert Aire Tie to alignment marks

Insert Aire Tie into first Rail up to Expansion Joint alignment mark. Slide second Rail over Aire Tie to the second Expansion Joint Alignment Mark, leaving a 1" gap between the Rails. Torque only one side of the Aire Tie, securing to Rail. Torque to **144 in-lbs**.

B. Ensure 1" gap

There must be a minimum 1" of space between both the edge of the Rail and the edge of the module, and between the two pieces of Rail, as shown below. The 1" of space between the edge of the Rail and the edge of the module is to allow proper installation of the Aire Lock End.

C. Install 8" Bonding Jumper

Install the 8" Bonding Jumper between the two modules.

- Alternatively two Aire Lugs or Module Grounding Lugs can be used with a 10 AWG or larger copper wire.
- Do not install modules over Expansion Joints.

A.

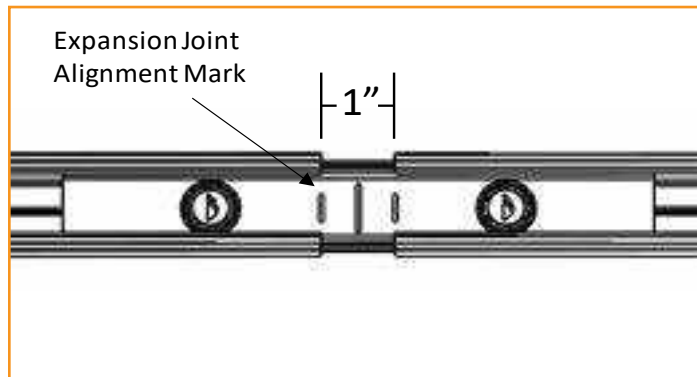

B.

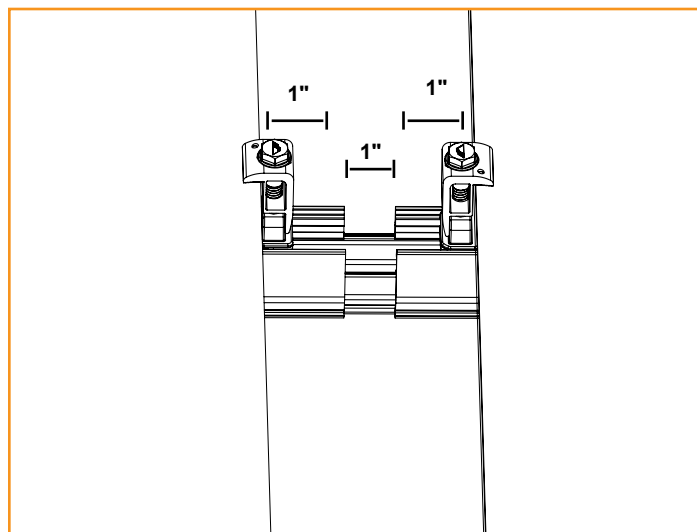

C.

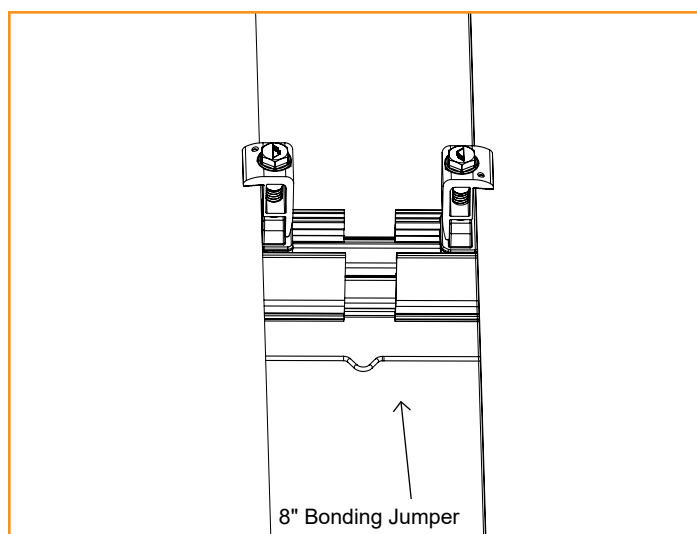

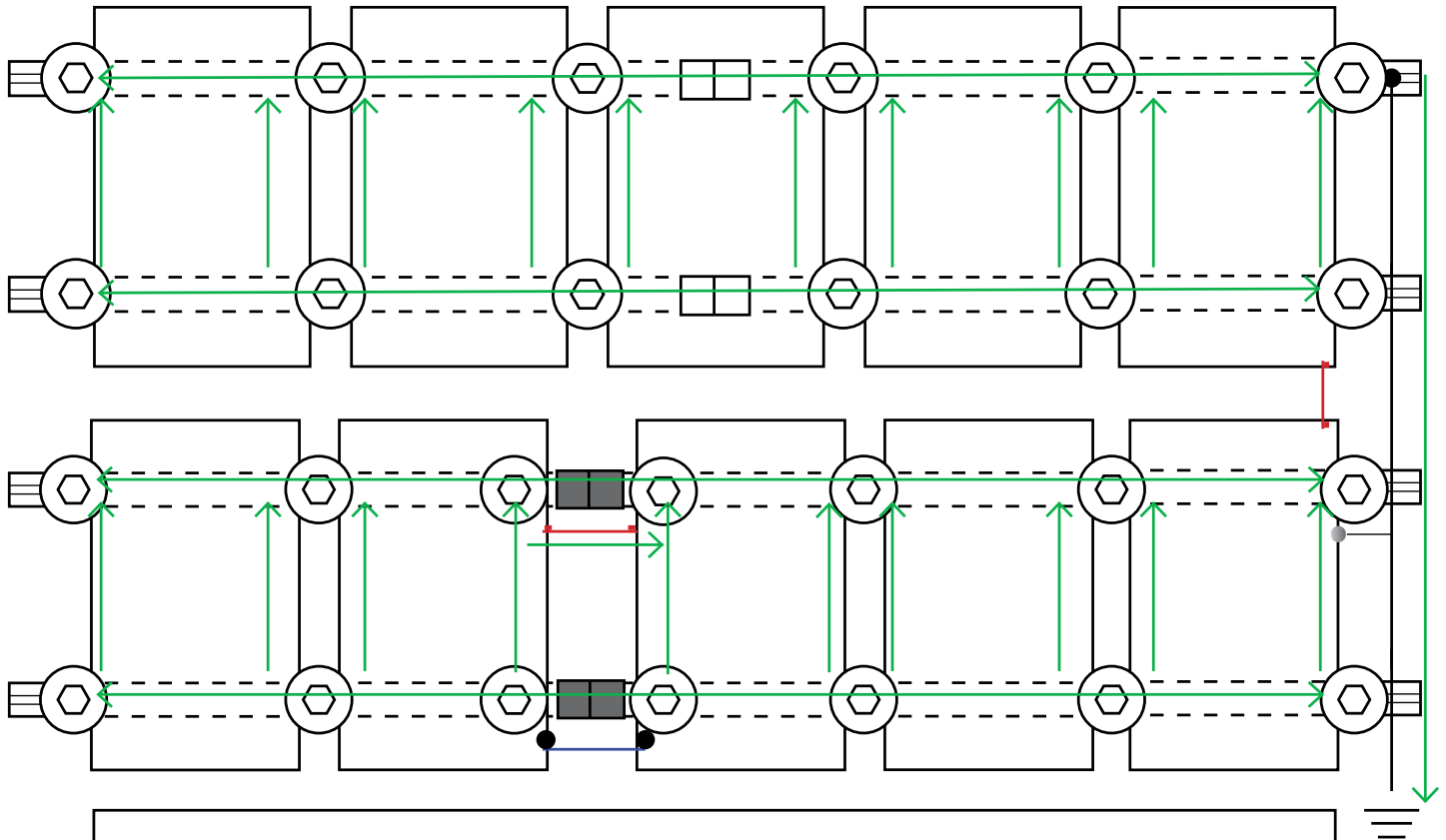

	Aire Lock Mid Aire Lock End Aire Lock Stealth		Grounding Lug*		Fault Current Ground Path		Minimum 10 AWG Copper Wire
	Aire Tie (Rail Connection)		Module Grounding Lug		8" Bonding Jumper**		
	Aire Tie Expansion Joint (Rail Connection)		Ground Lug with copper wire**				

*One Module Grounding Lug or Rail Grounding lug is required per row of a system.
Expansion joint bonding options:**
 (1) 8" bonding jumper attached to module frames.
 (2) PV grounding lugs attached to module frames with 10 AWG or larger ground wire.
 (3) Two grounding lugs installed to one row of rails with 10AWG or larger copper wire.

** The use of the 8" Bonding Jumper eliminates the need for row to row bonding. A minimum of one grounding lug per continuous array is required for earth ground.

During servicing or maintenance, if the Dynobond is used at a splice location or used between rows to bond rows together or if using a module lug instead of rail lug to bond rows together, module removal may disrupt the bonding path and could introduce the risk of electric shock. If module removal is required for servicing, then a Bonding Jumper shall be installed to the adjacent modules to maintain the ground path. Modules should only be removed by qualified persons in compliance with the instructions in this manual.

FLASHFOOT2

Locate roof rafters and mark locations on roof. Drill 1/4" pilot holes perpendicular to the roof and back fill with roofing manufacturers' approved sealant. Slide flashing between 1st and 2nd course of shingles, ensuring both that the flashing reaches under the 3rd shingle course and doesn't overhang the downhill shingle course. Line up with pilot hole and insert supplied lag bolt with washer through flashing. With a 7/16" Socket fully seat lag bolt. Place Cap onto flashing in desired orientation for E/W or N/S rails and rotate 180 degrees until it locks into place.

- Rail can be installed on either side of FlashFoot2 Cap.
- For additional details refer to the full [FlashFoot2 Installation Manual](#).

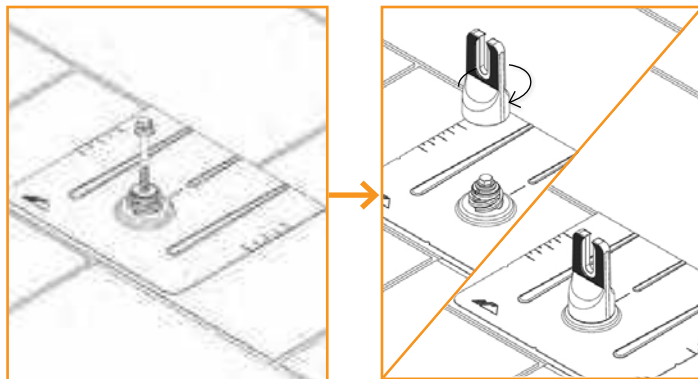

FLASHVUE

Locate rafters and snap vertical and horizontal lines to mark locations of flashings. Drill 1/4" pilot holes, then backfill with an approved sealant. Slide flashing between 1st and 2nd course of shingles, ensuring both that the flashing reaches under the 3rd shingle course and doesn't overhang the downhill shingle course. Line up pilot hole with View Port. Press Grip Cap onto flashing in desired orientation for E/W or N/S rails. Insert Lag Bolt with mechanically bonded washer through flashing. With a 7/16" Socket drive Lag Bolt until fully seated. FlashVue is now installed and ready for IronRidge Aire Rails. Attach rails to either side of the open slot using Aire Dock. Level rail at desired height, then torque to **250 in-lbs (21 ft-lbs)**. When installing GripCap+ on roofs with undulations greater than 1 inch, install GripCap+ in low points across the array as required.

- For additional details refer to the full [FlashVue Installation Manual](#).
- For additional details on the GripCap+ refer to the full [GripCap+ Installation Manual](#).

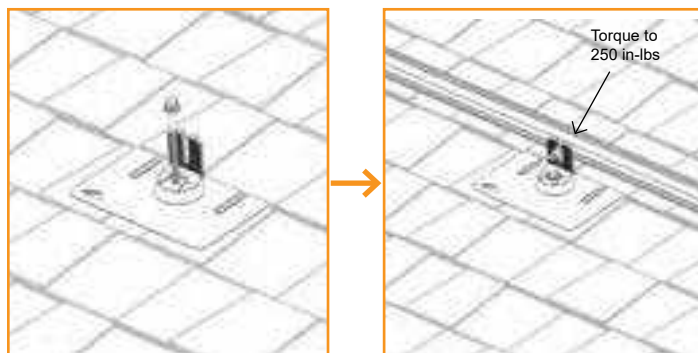

HUG (RAFTER)

Confirm shingle step does not exceed 1/8". Locate and mark centers of rafters to be mounted. Select the courses of shingles where mounts will be placed. Peel off release liner. Align HUG horizontally using the shingle edge or chalk line with the alignment grooves on the mount. Once in desired location, lightly press against roof to preliminarily hold the mount in place. Drive RD Structural Screw using 5/16" socket, ensuring that two screws are correctly installed into the center of the rafter. Drive screws until fully seated.

- Rail can be installed on either side of HUG.
- For complete installation requirements and limitations, please refer to the HUG [Installation Manual](#).
- HUG is only approved for installation with IronRidge RD Structural Screws.
- HUG cannot be installed between courses.

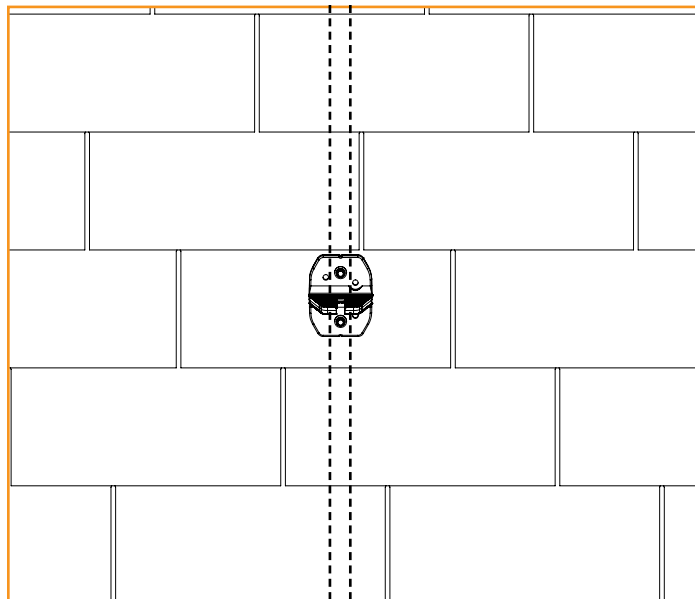

HUG (DECK)

Confirm shingle step does not exceed 1/8". Locate and mark attachment locations. Select the courses of shingles where mounts will be placed. Peel off release liner. Align HUG horizontally using the shingle edge or chalk line with the alignment grooves on the mount. Once in desired location, lightly press against roof to preliminarily hold the mount in place. Drive screws using 5/16" socket, until fully seated. All 6 RD Structural Screws must be used in deck mounted conditions.

- Rail can be installed on either side of HUG.
- For complete installation requirements and limitations, please refer to the HUG [Installation Manual](#).
- HUG is only approved for installation with IronRidge RD Structural Screws.

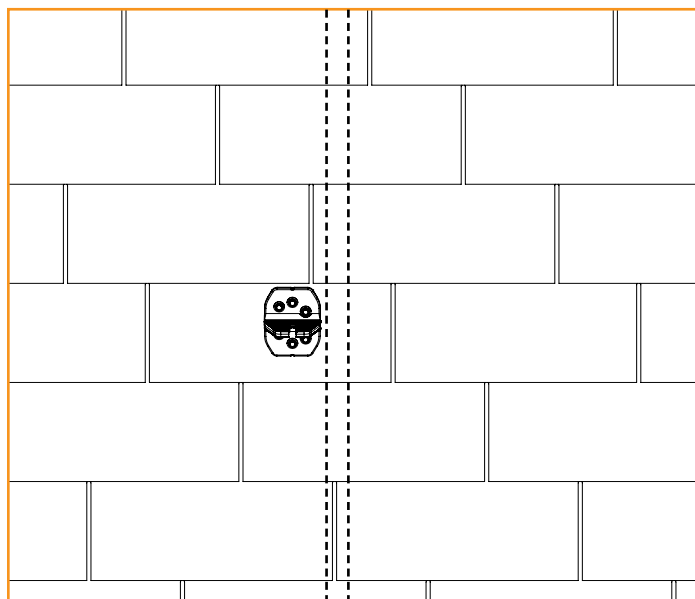

QM L-MOUNT

Locate roof rafters and mark locations on roof. Drill 7/32"(Lag) or 1/8"(ST) pilot holes perpendicular to the roof and back fill with roofing manufacturers' approved sealant. Slide flashing between 1st and 2nd course of shingles, ensuring both that the flashing reaches under the 3rd shingle course and doesn't overhang the downhill shingle course. Place L-foot on flute and rotate into desired position. Prepare lag bolt or structural screw with sealing washer. Use 1/2" socket to drive prepared lag bolt through L-foot until fully seated and L-foot can no longer rotate easily. Attach rail to L-Foot with Aire Dock and torque to **250 in-lbs (21 ft-lbs)**.

- Structural screw can be driven with T-30 hex head bit.
- For additional details refer to the full QM [Installation Manual](#).
- Aire Dock shall only be installed on back of vertical L-foot flange

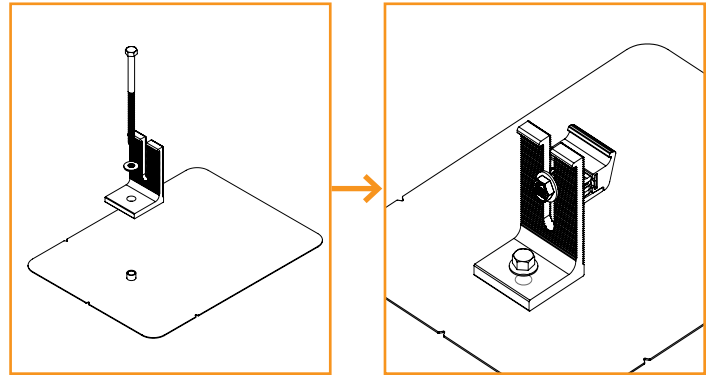

QM QBASE COMPOSITION MOUNT

Locate roof rafters and mark locations on roof. Align QBase vertical holes over center of rafter and mark. Drill two pilot holes with 7/32" drill bit, perpendicular to roof and back fill with roofing manufacturers' approved sealant. Set grade 8 cap screw through bottom of QBase, place QBase over drilled holes and secure lags. Screw Post to QBase. Proceed with roofing up until the flashing should be installed. Install flashing over mount. Allow roofing to proceed to the next course. Apply sealant where post and flashing meet, install EPDM counter flashing collar. Attach L-Foot on Standoff with hardware. Torque to **174 in-lbs (14.5 ft-lbs)**. Attach rail to L-Foot with Aire Dock and torque to **250 in-lbs (21 ft-lbs)**.

- For additional details refer to the full QM [Installation Manual](#).

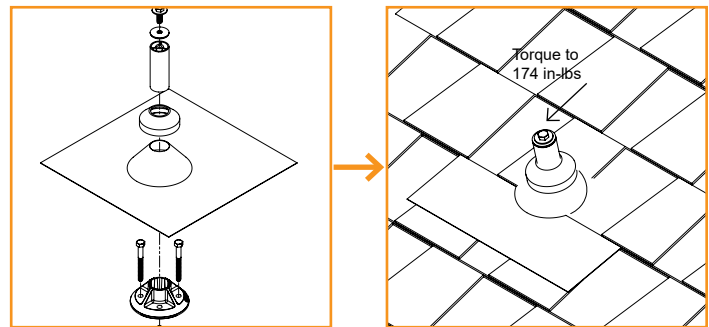

TILE ATTACHMENTS

AIRE ALL TILE HOOK

Remove tile and mark rafter. Position base over rafter, adjust arm if necessary and torque hardware to **132 in-lbs (11 ft-lbs)**. Use base as guide to drill 1/4" pilot holes, back fill with roofing manufacturer's approved sealant, then insert lag bolts and tighten until fully seated. Replace tiles and notch as necessary to ensure proper fit. Attach rails to pre installed Aire Dock and torque to **250 in-lbs (21-ft-lbs)**.

- Position arm near the center of valley for curved tiles.
- Position arm away from seam of joining flat tiles.
- Ensure top of hook does not extend above rail.
- Standalone Aire [All Tile Hook manual](#) available on website.

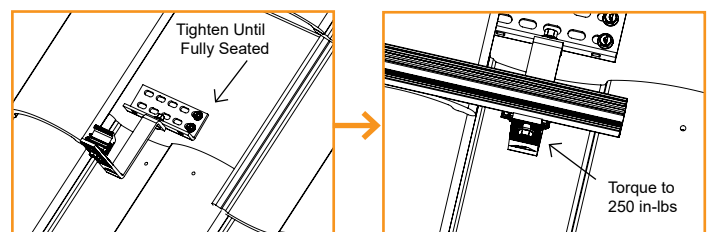
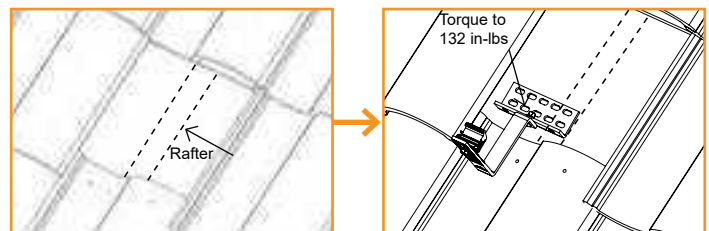

TILE ATTACHMENTS

KNOCKOUT TILE

Remove tile and mark rafter center. Use base as guide to drill 1/4" pilot hole and fill with roofing manufacturer's approved sealant. Install optional Roof Flashing and seal appropriately. Insert lag bolt with bonded washer through base (and flashing if used) and drive until fully seated. Insert Tile Replacement Flashing, lower onto base and apply pressure over the threaded post until it dimples the flashing. Place L-Foot over dimple and tap with hammer to punch threaded post through the flashing. Ensure punched pieces of flashing are cleared away. Form flashing as needed to sit flush with surrounding tiles, position L-Foot in desired orientation and torque hardware to **132 in-lbs (11 ft-lbs)**. Attach rail to L-Foot with Aire Dock and torque to **250 in-lbs (21 ft-lbs)**.

- Base can be installed in any orientation relative to rafter.
- Ensure L-Foot does not extend above rail.
- Optional deck level flashing is available. Standalone [installation manual](#) available on website
- Standalone [Knockout Tile manual](#) available on website.

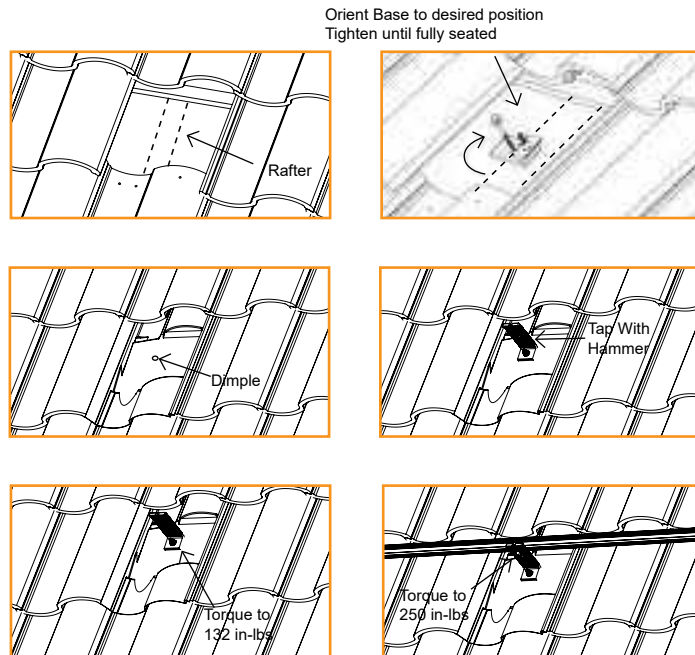

QM TILE REPLACEMENT

Remove tile and mark rafter. Measure up 8 3/4" from the adjacent tiles and mark horizontal across rafter. Align baseplate over rafter so that the lag holes align with the post groove. The orientation of the plate can be adjusted cross roof, mark location of lag holes on the roof. Drill two 1/8" Pilot holes and back fill with roofing manufacturers' approved sealant. Waterproof at underlayment level according to roofing manufacturers' instructions and the Tile Roofing Industry Alliance guidelines. Use T-30 Torx bit to lag base into position. Insert Grade 8 Serrated Flange Bolt into bottom of the Post, slide Post into Base channel. Line up post with the hole in the Tile Replacement Flashing. Leave loose for adjustments. Place Tile Replacement Flashing over the Post and Mount, allowing the flashing to properly interlock with surrounding tiles. Secure Post by tightening with channel lock pliers. Replace all tiles. Apply a bead of sealant where the post meets the flashing, slip EPDM collar over post and down to flashing. Attach L-Foot on Standoff with hardware. Torque to **174 in-lbs (14.5 ft-lbs)**. Attach rail to L-Foot with Aire Dock and torque to **250 in-lbs (21 ft-lbs)**.

- If deck level flashing is required, approved flashing methods include user supplied adhesive backed flexible flashing.
- For additional details refer to the full QM [Installation Manual](#).

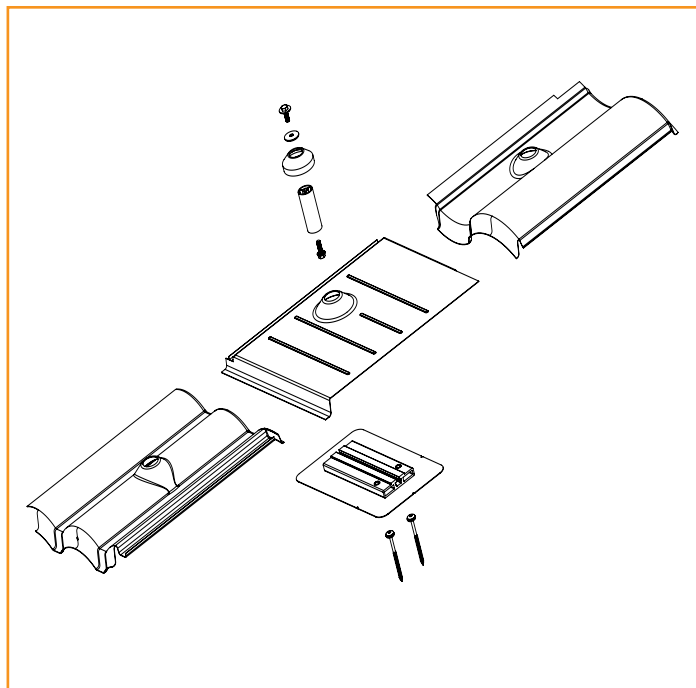

TILE AND ADDITIONAL ROOF TYPE ATTACHMENTS

QM QBASE UNIVERSAL TILE MOUNT

Remove tile and mark rafter. Measure up 6 5/8" from bottom of tiles and mark horizontally. Align QBase over rafter center and drill two 7/32" pilot holes, back fill with roofing manufacturers' approved sealant. Place grade-8 Cap Screw under QBase, lag QBase into rafter location. Install Sub-flashing, waterproof at underlayment level according to roofing manufacturers' instructions and the Tile Roofing Industry Alliance guidelines. Cut tile with diamond blade to allow post to pass through. Place tile in position and then install Post, tighten with channel lock pliers. Install 18"x18" flashing, pre-bent to follow the contour of the tile as required. Apply sealant where Post and Flashing meet and install EPDM counter flashing. Attach L-Foot on Standoff with hardware. Torque to **174 in-lbs (14.5 ft-lbs)**. Attach rails to L-Foot using Bonding Hardware and torque to **250 in-lbs (21-ft-lbs)**.

- For additional details refer to the full QM [Installation Manual](#).

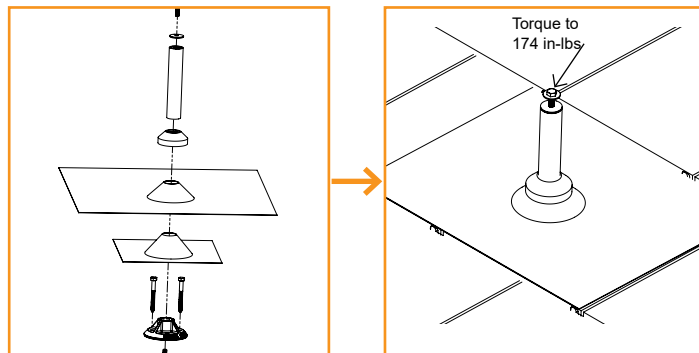

QM QBASE METAL, SHAKE AND SLATE

The QM QBase can be used to install on multiple roofing types with different installation methods.

- For instructions on installing the QBase on Slate refer to the full QM [Installation Manual](#).
- For instructions on installing the QBase on Shake refer to the full QM [Installation Manual](#).
- For instructions on installing the QBase on Metal Shingle refer to the full QM [Installation Manual](#).

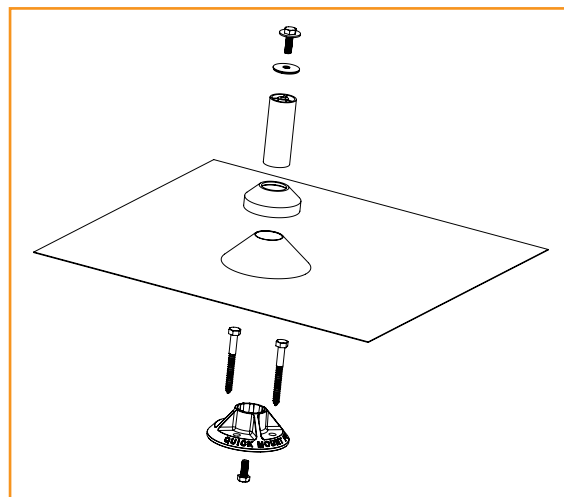

QM LYNX

Locate the desired mount placement over a roofing seam, make sure block is fully seated on metal seam. Torque Set Screws to **150 in-lbs(12.5 ft-lbs)** using 3/16" Hex Drive, alternate driving each bolt till required torque is met. Slide Hex Bolt into slot and to desired position. Place Rail attachment bracket over Hex Bolt and secure with Flange Nut, torque Flange Nut to **150 in-lbs(12.5 ft-lbs)** using 1/2" socket.

- For additional details and seam compatibility refer to the full QM [Installation Manual](#).
- Certification of Lynx clamp includes bonding to both painted and galvalume metal roofs.
- Aire Dock shall only be installed on back of vertical L-foot flange.
- The technology in this product is licensed by S-5!

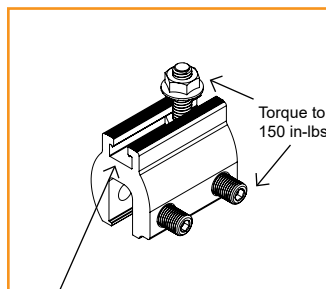

Slide hardware in to desired position

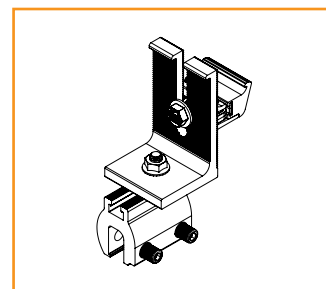

CABLE TRAY SYSTEM

The Aire Rails and Air Ties are certified for use as a Cable Tray System per NEMA VE1/CSA C22.2 #126.1. Wires may be routed in the Rail as a Cable Tray. Route all wires in Rail near module frame edge and avoid routing wires underneath the center of the module.

Install Aire Caps

Optional Aire Caps provide closure of the Cable Tray system and also prevent debris and pests from collecting inside the Rail. To install firmly press Aire Cap into Rail.

- Aire Caps can be installed on either end of the Rail.
- Water relief is provided at the bottom of the Cap.

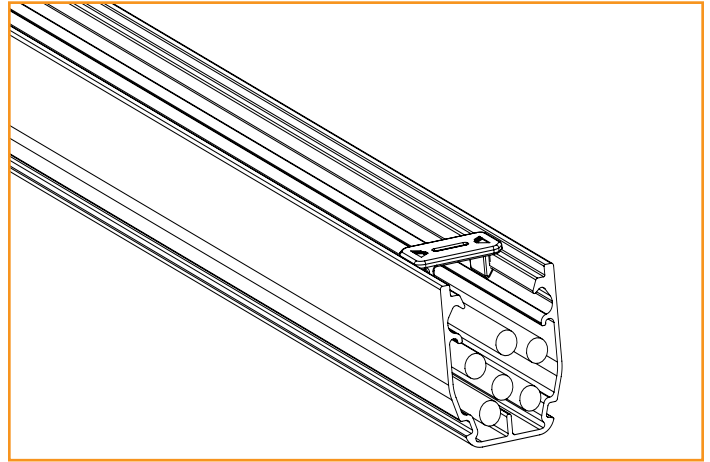

Install Aire Clips

- Firmly press Aire Clip into Rail Channel.
- Ensure Aire Clip runs perpendicular to Rail
- Aire Clips are to be installed no more than 55" apart, and within 12" of entry into the the Rail, per NEC Section 334.30.

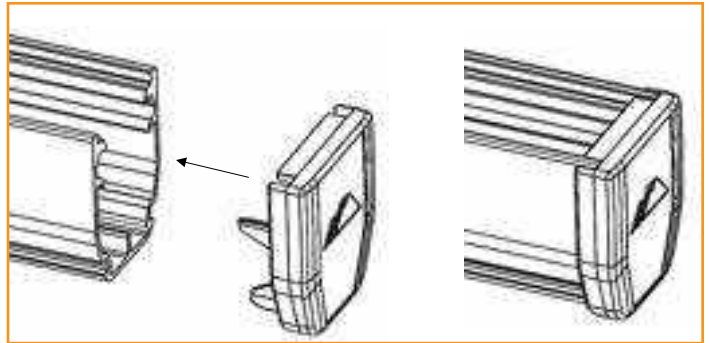

Removal of Wire Clips

Aire Clips can be removed by rotating quarter-turn counter-clockwise (by hand or using a flat-blade screwdriver) and pulling up.

Cable Tray Fill

Max cable fill is 2 in² cross section per NEC Article 392. Total sum of all cable cross sections installed in Cable Tray/Rail shall not exceed 25% of max cable fill. The Aire Rail always maintains a gap greater than 7/8" above the roof surface and does not require additional temperature derating.

- Review and calculate conductor ampacity per NEC Section 310.15 as required by local codes.

Examples of Cable Tray Fill Options that meet 25% fill:

- Option 1: (Qty10) - #12 AWG PV Wire
- Option 2: (Qty 8) - #10 AWG PV Wire
- Option 3: (Qty 5) - Enphase Q Cables
- Option 4: (Qty 5) - #10 AWG PV Wire + (Qty 2) - Enphase Q Cables
- Option 5: (Qty 6) - #12 AWG PV Wire + (Qty 2) - Enphase Q Cables

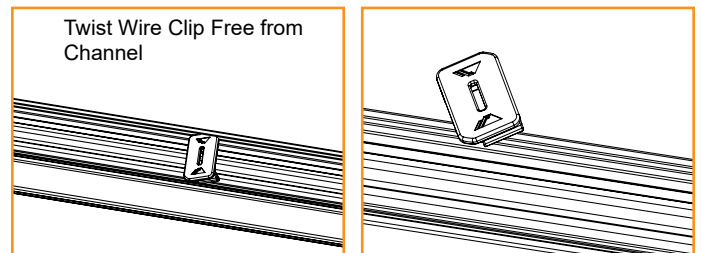
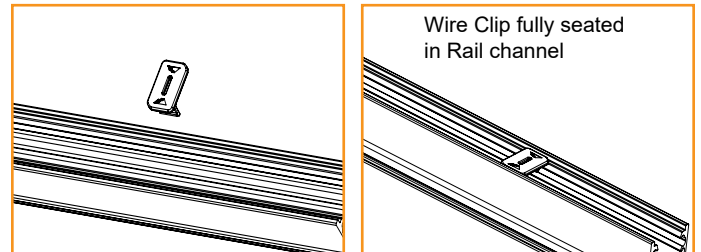

WARNING! DO NOT USE RAIL AS A WALKWAY, LADDER OR SUPPORT FOR PERSONNEL. USE ONLY AS A MECHANICAL SUPPORT FOR PV MODULES, WIRES AND CABLES.

AVERTISSEMENT! NE PAS UTILISER LE RAIL COMME PASSERELLE, ÉCHELLE OU SUPPORT POUR LE PERSONNEL. UTILISER UNIQUEMENT COMME SUPPORT MÉCANIQUE POUR LES MODULES PHOTOVOLTAÏQUE, FILS ET CÂBLES ÉLECTRIQUES.

AIRE MLPE MOUNT

Aire MLPE Mount Into Rail Channel

Install Aire MLPE Mount into rail channel by holding foldable wings and rotating the mount quarter turn clockwise as you insert it into the Rail channel. Final position of the Mount should be perpendicular to Rail channel. Foldable installation wings will lay flat in Rail channel.

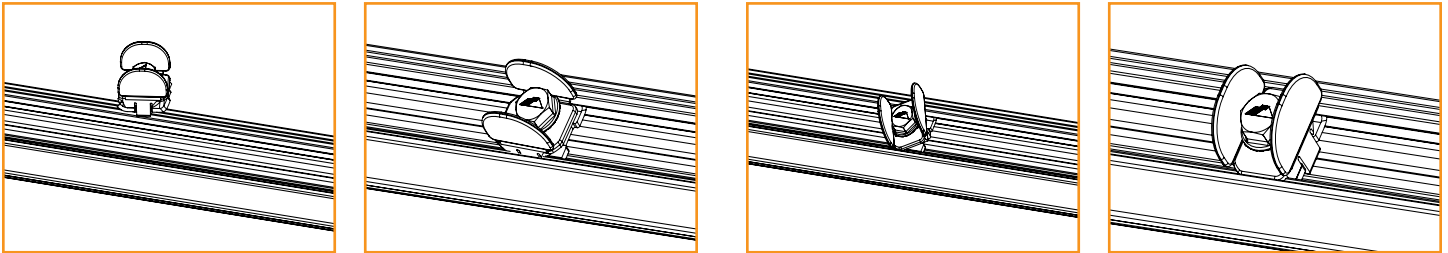

Attach MLPE to Rail via MLPE Mount

Slide the MLPE mounting bracket between the top of the Rail and the bottom side of the Aire MLPE bolt flange. Secure the assembly to the Rail by tightening the bolt. Torque to **144 in-lbs**.

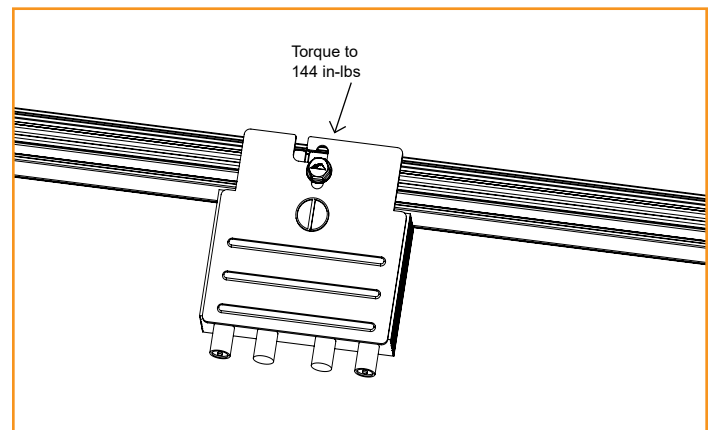
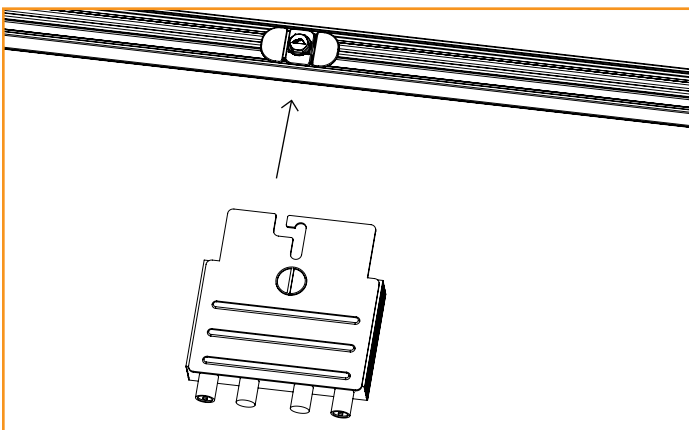

COMPATIBLE PRODUCTS

Enphase

M250-72, 250-60, M215-60, C250-72, S230, S280, IQ 6, IQ 6+, IQ IQ7, IQ 7A, IQ 7+, IQ7 PD, IQ 7X, Q Aggregator; IQ8-60, IQ8PLUS-72, IQ8A-72, IQ8H-208-72, IQ8H-240-72, IQ8M-72, may be followed by -2-US

Darfon

MIG240, MIG300, G320, G640

Solar Edge

M1600, P300, P320, P340, P370, P400, P401, P405, P485, P505, P600, P700, P730, P750, P800p, P800s, P801, P850, P860, P950, P960, P1100, P1101, S440, S500, S500B, S650B, S1200, S1201

SMA

RoofCommKit-P2-US, TS4-R Module Retrofit Kits (TS4-R-S, TS4-R-O, TS4-R-F)

Generac

S2502

Hoymiles

HM-xxxNT

where xxx can be 300, 350, 400, 600, 700, 800, 1200 and 1500

Yotta

DPI 208/480

Tigo

Tigo Access Point (TAP)

TS4-R-X (where X can be F, M, O, or S)

TS4-R-X-DUO (where X can be M, O, or S)

TS4-A-X (where X can be F, 2F, O, O-DUO, or S)

AP Systems

DS3, QS1, QT2 and YC600

NEP

BDM-300, BDM-300X2, BDM-550, BDM-650 and BDM-800

- Remove Grounding Washer on AP Systems QS1, QT2, DS3 and YC600 or Yotta inverters before installing to Aire rails.
- Remove the Stainless Steel Clip on Tigo-"A" MLPE Devices before attaching to Aire rails.
- Use the number of Aire MLPE Hardware allowed by the MLPE mounting flange. Some will require 1 kit and others 2 kits.

CONTOUR

Install Contour

Install Contour on a completed array.

A. Start by placing Contour Clamp on module frame within 12 inches of the down roof corner of the array. Each piece of 84" Contour Trim must be supported by two Clamps. Clamps must be installed in the 12" clamping zones at edge of trim. Once trim is placed and in position, secure trim by tightening Clamp set screw to **80 in-lbs**.

B. Multiple Contour pieces can be joined using Contour Splice. Install Splice on existing Contour edge and install Clamps in appropriate clamping zones for next piece of trim. Place trim on Clamps, slide into splice to join two pieces together. Secure Contour by tightening Clamp set screw to **80 in-lbs**. Repeat as needed across the array.

C. Cut trim to line up with edge of array.

D. Install Clamps within clamping zones on side of array. Install second Clamp as needed up array. Place Corner Cap on trim and slide side trim to align with Cap. Repeat as needed along roof for both inside and outside corners.

E. Use optional End Caps to cover any exposed edges of Contour as desired.

- Do not install on side of array facing roof peak.
- Contour can be installed with 1 clamp if trim section is 12" long (or shorter) and has a splice attached on one end, on which the section of trim the 12" section is spliced to also has 2 clamps.
- Contour Trim when installed when installed up roof requires the use of Aire Stealth Clamps.
- Wind Speed: no restrictions
- Ground Snow: up to 90 PSF

A.

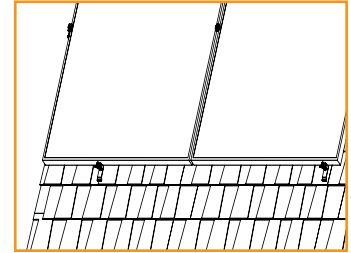
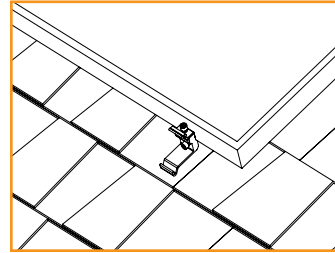
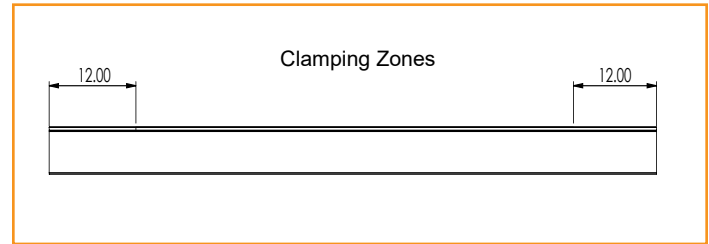

B.

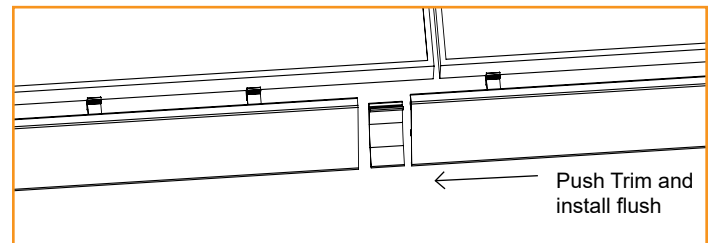

C.

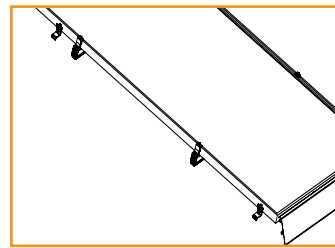

D.

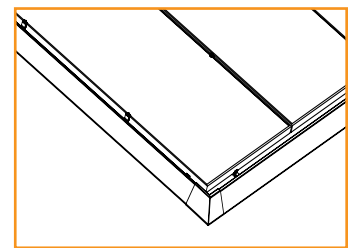

E.

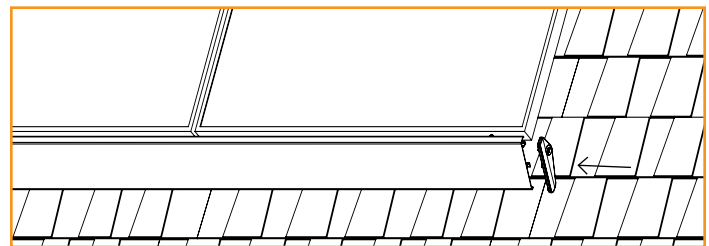

FRAME COMPATIBILITY

Contour Clamp has been tested or evaluated with all modules having frames within the referenced dimensions. Be sure the specific module being used meets the dimension requirements.

- Flange Thickness: 1-3.5mm
- Usable Flange Length: 0-33mm.

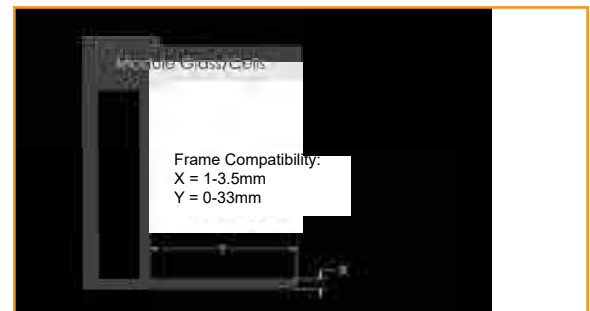

A.

Prior to installation, use step drill bit to place pass through holes for conduits or water-tight connectors. Drill bit starter locations are provided on the sides and front of enclosure.

- Do not install conduit facing up roof.

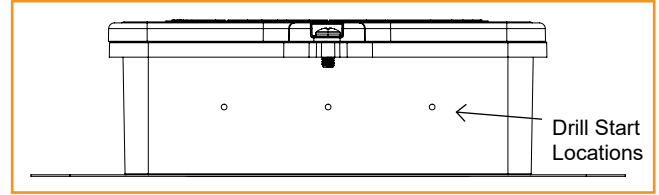

B (Rail).

Use rail-specific MLPE mounting hardware to attach Rail Hangers to rail. Ensure junction box is pushed as close to the rail as possible. Torque to 80-in lbs (1/2" or 7/16" socket).

- Do not over-tighten
- If installing in areas with ground snow loads greater than 40 psf, install JayBox under module directly next to module frame edge.

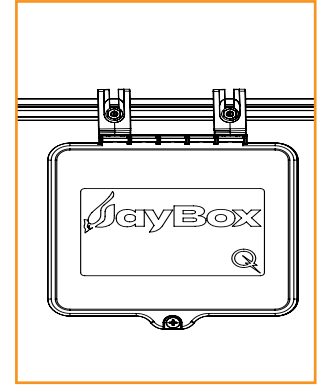
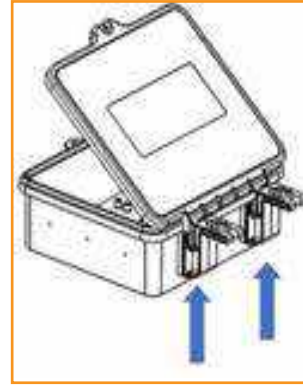

B (Shingle).

Align sealing oval of box to align with mating feature on flashing. An EPDM foam gasket is pre-installed to the underside of the junction box to seal the flashing to the box without the need for additional sealant. Secure with supplied #12 x 1-3/4" deck screws (2x) until the junction box is pulled tight to the flashing. Do not over-tighten screws to avoid stripping screws in OSB.

- If installing pass through fittings, ensure that the JayBox and roof deck are both properly prepared. Complete installation process before attaching the Jaybox to the deck.
- Do not install JayBox under shingle seam as illustrated below.

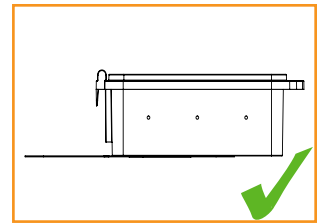
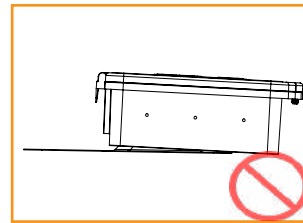

C.

Install wiring, conduit and fittings per NEC Requirements and following local AHJ guidance. Using Philips Head Driver tighten the bolt.

- For additional details refer to the full QM [Installation Manual](#).

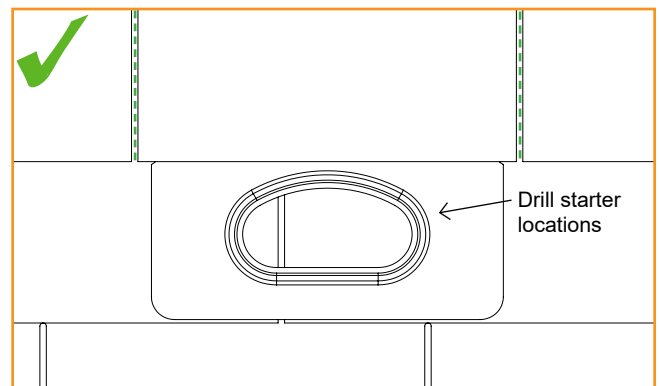
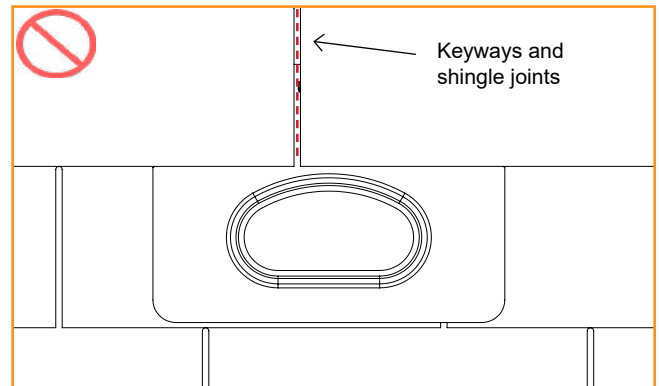

CONDUIT MOUNT

QM CONDUIT MOUNT - COMPOSITION SHINGLE

Place conduit mounts along path of conduit. Lift shingle above mount location and insert flashing into position. Mark center for drilling, remove flashing and drill pilot hole with 1/8" bit. Clean area, fill hole with roofing manufacturer's approved sealant. Lift shingle and slide Conduit Mount into place. Prepare the lag bolt with sealing washer and pipe clamp (not included). Insert lag through hole in block and drill with 7/16" socket until block is tight.

- Install mounts as required to support conduit across the roof.
- For additional details refer to the full QM [Installation Manual](#).

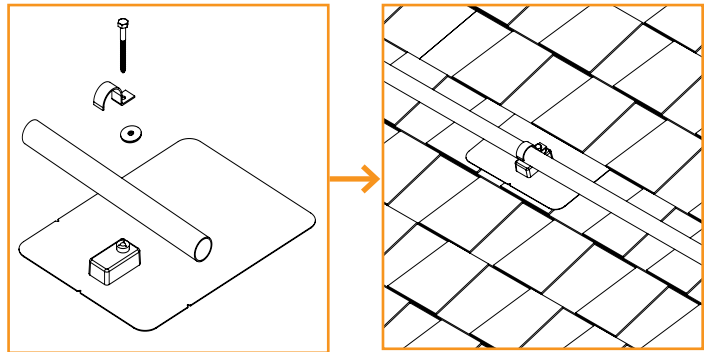

QM BUG - COMPOSITION SHINGLE

Place BUG conduit mounts along path of conduit. Clean area, place mount and drive RD Structural Screw using 5/16" socket. Prepare the Tri-lobe Screw and pipe clamp (not included). Insert screw in an unused hole in block and drill with 5/16" socket until screw is tight.

- Install mounts as required to support conduit across the roof.
- For additional details refer to the full QM [Installation Manual](#).

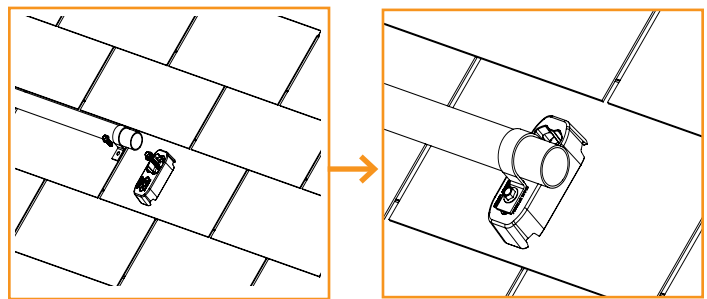

QM CONDUIT MOUNT - TILE

Remove the tile that the mount will be installed on, and the tiles in the course above it. Lift the bottom of the tile and slide the bottom clamp over the bottom edge of the tile. Insert the 4" tap bolt through the slot into the threaded hole and use a 7/16" socket to thread the screw. Tighten until the top clamp hook end unbends and forms a 90 degree angle with the tile. Use the Cap Screw (included) to attach your pipe clamp (not included) to bottom clamp. Insert conduit and tighten with 7/16" socket.

- The clamp is reversible, use the wider hook end on tile greater than 1" thick and the thinner hook end on tiles less than 1" thick.
- The installation process is the same on curved tile, make sure that the Conduit Mount is installed on the crown (high point) of the tile.
- Install mounts as required to support conduit across the roof.
- For additional details refer to the full QM [Installation Manual](#).

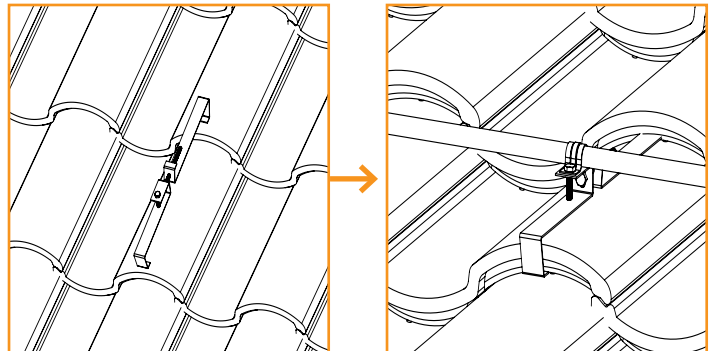

MODULE COMPATIBILITY

The Aire System has been tested and evaluated to UL 2703 for bonding, grounding, mechanical loading and fire classification, and may be used to ground and/or mount PV modules listed to UL 1703 or UL 61730. A list of approved modules is included below. Unless otherwise noted, "xxx" refers to the module power rating and both black and silver frames are included in the certification.

FRAMED MODULE LIST

MAKE	MODELS
Adani	Adani modules with 35 and 40 mm frames ASX-Y-ZZ-xxx Where "X" can be B, M or P, "Y" can be 6, 7 or M10 and "ZZ" can be blank, 144, PERC, B-PERC, or AB-PERC
AIONRISE	AIONRISE modules with 35 and 40 mm frames AIONyyG1-xxx Where "yy" can be 60 or 72
Amerisolar	Amerisolar modules with 35 and 40 mm frames AS-bYxxxZ Where "b" can be 5 or 6; "Y" can be M, P, M27, P27, M30, or P30; and "Z" can be blank, W or WB
Aptos Solar	Aptos modules with 35 and 40 mm frames DNA-yy-zzaa-xxx Where "yy" can be 108, 120 or 144; "zz" can be MF or BF; and "aa" can be 10, 23 or 26
Astronergy Solar	Astronergy modules with 30, 35 and 40 mm frames aaSMbbyyC/zz-xxx Where "aa" can be CH or A; "bb" can be 60, 66, or 72; "yy" can be blank, 10 or 12; "C" can M, P, M(BL), M-HC, M(BL)-HC, P-HC, M(DG), M(DGT) or N(DG); and "zz" can be blank, HV, F-B, or F-BH
ASUN	ASUN modules with 35 and 40 mm frames ASUN-xxx-YYZZ-aa Where "YY" can be 60 or 72; "ZZ" can be M, or MH5; and "aa" can be blank or BB
Auxin	Auxin modules with 35 and 40 mm frames AXNCyzAxxxB Where "C" can be 6, 10 or G1; "y" can be M or P; "z" can be blank, 08, 09, 610, 11, or 612; and "A" can be blank, F, M or T; and "B" can be blank, A, B, C or W
Axitec	Axitec Modules with 30, 35 and 40 mm frames AC-xxxY/aaZZb Where "Y" can be M, P, MB, MBT or MH; "aa" can be blank, 125- or 156-; "ZZ" can be 54, 60, 72, 108, 120, or 144; "b" can be S, X, V, VB, XV, or MX
Bluesun Solar	Bluesun modules with 30 and 35 mm frames BSMxxxY-AAA Where "Y" can be M or M10; and "AAA" can be 54HPH, 60HPH or 72HBD
Boviet	Boviet modules with 35 and 40 mm frames BVMZZaaYY-xxxBcc Where "ZZ" can be 66 or 76; "aa" can be 9, 10 or 12; "YY" is M or P; and "B" can be blank, L or S; and "cc" can be blank, H, H-BF, H-BF-DG, H-HC, H-HC-BF, H-HC-BF-DG, HC-BF or HC-BF-DG
BYD	BYD modules with 35 mm frames BYDxxxAY-ZZ Where "A" can be M6, P6, MH, MLT or PH; "Y" can be C or K; and "ZZ" can be 30 or 36
Canadian Solar	Canadian Solar modules with 30, 32, 35 and 40 mm frames CSbY-xxxZ Where "b" can be 1, 3, 6 or 7 "Y" can be H, K, L, N, P, R, U, V, W, X or Y; and "Z" can be M, P, MS, PX, M-SD, P-AG, P-SD, MB-AG, PB-AG, MS-AG, MS-HL, or MS-SD
CertainTeed	CertainTeed modules with 30, 35 and 40 mm frames CTBBxxxYZZ-AA Where "BB" can be blank or M10; "Y" can be M, P, or HC; "ZZ" can be 00, 01, 10, or 11; and "AA" can be 01, 02, 03, 04, 06, 08 or 09

MODULE COMPATIBILITY

Crossroads Solar	Crossroads Solar modules with 40 mm frames Crossroads Solar xxx
CSUN	Csun modules with 35 and 40 mm frames YYxxx-zzAbb Where "YY" is CSUN or SST; "zz" is blank, 60, or 72; and "A" is blank, P, M or MM; "bb" is blank, BB, 5BB, BW, or ROOF
Dehui	Dehui modules with 30, 35 and 40 mm frames DH-MYYYYZ-xxx Where "YYY" can be 760, 772, 860, 872; and "Z" can be B, F or W
Ecosolargy	Ecosolargy modules with 35 and 40 mm frames ECOxxxYzzA-bbD Where "Y" can be A, H, S, or T; "zz" can be 125 or 156; "A" can be M or P; "bb" can be 60 or 72; and "D" can be blank or B
Emmvee	Emmvee modules with 35 mm frames Exxx-YYZZZ-A Where "YY" can be M, P, HCM, HCMW, HCBG, HCBT; "ZZZ" can be 72, 120 or 144; and "A" can be blank or B
ET Solar	ET Solar modules with 30, 35 and 40 mm frames ET-YZZZxxxAA Where "Y" can be P, L, or M; "ZZZ" can be 660, 660BH, 672, 672BH, 754BH, 766BH, 772BH; and "AA" can be GL, TB, TW, WB, WW, BB, WBG, WWG, WBAC, WBCO, WWCO, WWBCO or BBAC
Flex	Flex modules with 35 and 40 mm frames FXS-xxxYY-ZZ; Where "YY" can be BB or BC; and "ZZ" can be MAA1B, MAA1W, MAB1W, SAA1B, SAA1W, SAC1B, SAC1W, SAD1W, SBA1B, SBA1W, SBC1B, or SBC1W
Freedom Forever	Freedom Forever modules with 35 mm frames FF-MPa-BBB-xxx Where "a" can be blank or 1
Freevolt	Freevolt modules with 35 mm frames ECP-PVGRAF-144HC-xxx
GCL	GCL modules with 35 mm and 40 mm frames GCL-ab/YY xxx Where "a" can be M or P; "b" can be 3 or 6; and "YY" can be 60, 72, 72H, or 72DH
GigaWatt Solar	Gigawatt modules with 40 mm frames GWxxxYY Where "YY" can be either PB or MB
Goldi	Goldi modules with 35 mm frames GS10-Byyy-zz-xxx Where "yyy" can be 108 or 144; and "zz" can be GF or TF
Grape Solar	Grape modules with 35 mm frames GS-M120-xxx-FAB1
GreenWatts Solar	GreenWatts modules with 30 and 35mm frames HSYY-A-xxx-ZZ Where "YY" can be 54, 60, 66, 72 or 78; "A" can be blank or F; and "ZZ" can be MN or BOB
Hansol	Hansol modules with 35 and 40 mm frames HSxxxYY-zz Where "YY" can be PB, PD, PE, TB, TD, UB, UD, or UE; and "zz" can be AH2, AN1, AN3, AN4, HH2, HV1, or JH2
Hanwa Solar	Hanwha Solar modules with 40 mm frames HSLaaP6-YY-1-xxxZ Where "aa" can be either 60 or 72; "YY" can be PA or PB; and "Z" can be blank or B

MODULE COMPATIBILITY

Hanwha Q CELLS	<p>Hanwha Q CELLS Modules with 32, 35, 40 mm frames aaYY-ZZ-xxx where "aa" can be Q. or B.; "YY" can be PLUS, PRO, PEAK, LINE PRO, LINE PLUS, PLUS DUO, PEAK DUO or Tron; and "ZZ" can be G3, G3.1, G4, G4.1, L-G2, L-G2.3, L-G3, L-G3.1, L-G3y, L-G4, L-G4.2, L-G4y, LG4.2/TAA, BFR-G3, BLK-G3, BFR-G3.1, BLK-G3.1, BFR-G4, BFR-G4.1, BFR G4.3, BLK-G4.1, G4/SC, G4.1/SC, G4.1/TAA, G4.1/MAX, BFR G4.1/TAA, BFR G4.1/MAX, BLK G4.1/TAA, BLK G4.1/SC, EC-G4.4, G5, G5/SC, G5/TS, BLK-G5, BLK-G5/SC, BLK-G5/TS, L-G5, L-G5.1, L-G5.2, L-G5.2/H, L-G5.3, G6, G6/SC, G6/TS, G6+/TS, G6+, BLK-G6, L-G6, L-G6.1, L-G6.2, L-G6.3, G7, BLK-G6+, BLK-G6+/AC, BLK-G6+/HL, BLK-G6+/SC, BLK-G6/TS, BLK-G6+/TS, BLK-G7, G7.2, G8, BLK-G8, G8+, BLK-G8+ L-G7, L-G7.1, L-G7.2, L-G7.3, L-G8, L-G8.1, L-G8.2, L-G8.3, L-G8.3/BFF, L-G8.3/BFG, L-G8.3/BGT, M-G2+, BLK M-G2+, ML-G9, BLK ML-G9, ML-G9+, BLK ML-G9+, BLK-G10, BLK-G10+, BLK G10+/AC, BLK-G10+/HL, ML-G10, BLK ML-G10, ML-G10+, BLK ML-G10+, ML-G10.a, BLK ML-G10.a, ML-G10.a+, BLK ML-G10.a+, BLK ML-G10 +/t, BLK ML-G10+/TS, XL-G9, XL-G9.2, XL-G9.3, XL-G9.3/BFG, XL-G10.2, XL-G10.3, XL-G10.c, XL-G10.d, XL-G10.d/BFG, XL-G10.3/BFG, XL-G11.2, XL-G11.3, XL-G11.3/BFG or XL-G11S.3/BFG</p>
Heliene	<p>Heliene modules with 35 and 40 mm frames YYZZxxxA Where "YY" can be 36, 60, 72, 96, 108, 120, 132, 144 or 156; "ZZ" can be HC, M, P, or MBLK; and "A" can be blank, HomePV, Bifacial, M10-SL, M10-SL-BLK, M10 Bifacial or M10 SL-Bifacial</p>
HT-SAAE	<p>HT-SAAE modules with 35 and 40 mm frames HTyy-aaaZ-xxx Where "yy" can be 60, 66, 72 or 78, "aaa" can be 18, 156 or 166, "Z" can be M, P, M-C, P-C, M(S), M(VS), M(V), P(V), M(V)-C, P(V)-C, or X</p>
Hyperion Solar (Runergy)	<p>Hyperion modules with 30 and 35 mm frames HY-DHzzzA8-xxxB Where "zzz" can be 108 or 144; "A" can be N or P; and "B" can be blank or B</p>
Hyundai	<p>Hyundai modules with 32, 33, 35 and 40 mm frames HiY-SxxxZZ Where "Y" can be A, D or S; "S" can be M or S; and "ZZ" can be GI, HG, HI, KI, MI, MF, MG, PI, RI, RG, RG(BF), RG(BK), SG, TI, TG, YH(BK) or XG(BK)</p>
Itek	<p>Itek Modules with 40 mm frames IT-xxx-YY Where "YY" can be blank, HE, or SE, or SE72</p>
JA Solar	<p>JA Solar modules with 30, 35 and 40 mm frames JAyyzz-bbww-xxx/aa Where "yy" can be M, P, M6 or P6; "zz" can be blank, (K), (L), (R), (V), (BK), (FA), (TG), (FA)(R), (L)(BK), (L)(TG), (R)(BK), (R)(TG), (V)(BK), (BK)(TG), or (L)(BK)(TG); "bb" can be 48, 54, 60, 66, 72 or 78; "ww" can be D09, D10, D20, D30, S01, S02, S03, S06, S09, S10, S12, S17, S20, S30 or S31; and "aa" can be BP, MB, MR, SI, SC, PR, 3BB, 4BB, 4BB/RE, 5BB</p>
Jinko	<p>Jinko modules with 35 and 40 mm frames JKMYxxxZZ-aa Where "Y" can either be blank or S; "ZZ" can be M, N, P, or PP; and "aa" can be blank, 54HL4-B, 60, 60B, 60H, 60L, 60BL, 60HL, 60HB, 60HBL, 6HBL-EP, 60-J4, 60B-J4, 60B-EP, 60(Plus), 60-V, 60-MX, 6RL3, 6RL3-B, 6TL3-B, 7RL3-V, 7RL3-TV, 72, 72B, 72-J4, 72B-J4, 72(Plus), 72-V, 72H-V, 72L-V, 72HL-V, 72HBL-V, 72HL4-V, 72HL4-BDV, 72HL4-TV, 72-MX, 72H-BDVP, 72HL-TV, or 72HL-V-MX3</p>
KB Solar	<p>KB Solar modules with 35 mm frames KBS-xxx-Mono-YY Where "YY" can be blank or BF</p>
Kyocera	<p>Kyocera Modules KYxxxZZ-AA Where "Y" can be D or U; "ZZ" can be blank, GX, or SX; and "AA" can be LPU, LFU, UPU, LPS, LPB, LFB, LFBS, LFB2, LPB2, 3AC, 3BC, 3FC, 4AC, 4BC, 4FC, 4UC, 5AC, 5BC, 5FC, 5UC, 6BC, 6FC, 8BC, 6MCA, or 6MPA</p>
LA Solar	<p>LA Solar modules with 35 mm frames LSxxxYY Where "YY" can be BF, BL, BLA, HC or ST</p>

MODULE COMPATIBILITY

LG	<p>LG modules with 35 and 40 mm frames LGxxxYaZ-bb Where "Y" can be A, E, M, N, Q, S; "a" can be A, 1, 2 or 3 "Z" can be C, K, T, or W; and "bb" can be A3, A5, A6, B3, B6, E6, E6.AW5, G3, G4, J5, K4, L5, N5, V5, V6</p>
Longi	<p>Longi modules with 30, 35 and 40 mm frames LRa-YYZZ-xxxM Where "a" can be 4, 5 or 6; "YY" can be blank, 54, 60, 66, or 72; and "ZZ" can be blank, BK, BP, HV, PB, PE, PH, HBD, HIB, HIH, HPB, HPH, HIBD, HABB or HABD</p>
Maxeon	<p>Maxeon modules with 35, 40 and 46 mm frames SPR-AAAY-xxx-zzz Where "AAA" can be MAX, P or X; "Y" can be 3, 5, 6, 21 or 22; and "zzz" can be R, BLK, BLK-R, COM or UPP</p>
Meyer Burger	<p>Meyer Burger Modules with 35 mm frames Meyer Burger Black, White or Glass</p>
Mission Solar (mSolar)	<p>Mission Solar modules with 33, 35 and 40 mm frames YYYbb-xxxZZaa Where "YYY" can be MSE, TXI or TXS; "bb" can be blank, 6, 10 or 60A; "ZZ" can be blank, HT, MM, SE, SO, SQ, SR, SX, TS, 108, 120 or 144; and "aa" can be blank, 0B, 2B, BB, BW, 1J, 4J, 4S, 5K, 5R, 5T, 60, 6J, 6S, 6W, 6Z, 8K, 8T, 9R, 9S or 9Z</p>
Mitrex	<p>Mitrex modules with 30 and 40 mm frames Mxxx-XYZ Where "X" can be A, B, I or L; "Y" can be 1 or 3; and "Z" can be F or H</p>
Mitsubishi	<p>Mitsubishi modules PV-MYYxxxZZ Where "YY" can be LE or JE; and "ZZ" can be either HD, HD2, or FB</p>
Moltech	<p>IM and XS series modules with 40 mm frames</p>
Navitas	<p>Navitas Modules with 35 mm frames NSMxxx-yyy Where "yyy" can be 120, 132 or 144</p>
Next Energy Alliance	<p>Next Energy Alliance modules with 35 and 40 mm frames yyNEA-xxxZZ where "yy" can be blank or US; "ZZ" can be M, MB or M-60</p>
NE Solar	<p>NE Solar modules with 30, 35 and 40 mm frames NESExxx-zzMHX-yy Where "zz" can be 54, 60 or 72; "X" can be blank or B; and "yy" can be M6 or M10</p>
Neo Solar Power	<p>Neo Solar Power modules with 35 mm frames D6YxxxZZaa Where "Y" can be M or P; "ZZ" can be B3A, B4A, E3A, E4A, H3A, H4A; and "aa" can be blank, (TF), ME or ME (TF)</p>
Panasonic (HIT)	<p>Panasonic modules with 35 and 40 mm frames VBHNxxxYYzZA Where "YY" can be either KA, RA, SA or ZA; "zz" can be either 01, 02, 03, 04, 06, 06B, 11, 11B, 15, 15B, 16, 16B, 17, or 18; and "A" can be blank, E, G, or N</p>
Panasonic (EverVolt)	<p>Panasonic modules with 30 mm frames EVPVxxxA Where "A" can be blank or H, K, HK or PK</p>
Peimar	<p>Peimar modules with 40 mm frames SbxxxYzz Where "b" can be G, M or P; "Y" can be M or P; and "zz" can be blank, (BF) or (FB)</p>
Philadelphia Solar	<p>Philadelphia modules with 30, 35 and 40 mm frames PS-YzzAA-xxxW Where "Y" can be M or P; "zz" can be 60, 72, 108 or 144; "AA" can be blank, (BF), (HC) or (HCBF); and "W" can be blank or W</p>

MODULE COMPATIBILITY

Phono Solar	Phono Solar modules with 30, 35 and 40 mm frames PSxxxY-ZZ/A Where "Y" can be M, M1, MH, M1H, M4, M4H, M5GF, M5GFH, M6, M6H, M8, M8H, M8GF, M8GFH or P; "ZZ" can be 18, 20 or 24; and "A" can be F, T, TH, THB, U, UH, UHB, VH or VHB
Prism Solar	Prism Solar modules with 35 mm frames PST-xxxW-M72Y Where "Y" can be H, HB or HBI
Rayzon Solar	Rayzon Solar modules with 35 and 40 mm frames RSxxxWC
Recom	Recom modules with 35 and 40 mm frames RCM-xxx-6yy Where "yy" can be MA, MB, ME or MF
REC Solar	REC modules with 30 and 38 mm frames RECxxxYYZZ Where "YY" can be AA, M, NP, NP2, NP3, PE, PE72, TP, TP2, TP2M, TP2SM, TP2S, TP3M or TP4; and "ZZ" can be blank, Black, BLK, BLK2, SLV, 72, Pure, Pure-R, Pure-RX or Pure 2
Renesola	ReneSola modules with 35 and 40 mm frames AAxxxY-ZZ Where "AA" can be SPM(SLP) or JC; "Y" can be blank, F, M or S; and "ZZ" can be blank, Ab, Ab-b, Abh, Abh-b, Abv, Abv-b, Bb, Bb-b, Bbh, Bbh-b, Bbv, Bbv-b, Db, Db-b, or 24/Bb
Renogy	Renogy Modules with 35 and 40 mm frames RZZ-xxxY-AAA Where "ZZ" can be NG or SP; "Y" can be D or P; and "AAA" can be blank, 144, BB-108, BB-120 or BK-120
Risen	Risen Modules with 30, 35 and 40 mm frames RSMyy-a-xxxZZ Where "yy" can be 60, 72, 110, 120, 132 or 144; "a" can be 6, 7 or 8; and "ZZ" can be M, P or BMDG
Saatvik	Saatvik Modules with 35 mm frames SGExxx-YYYZZZ Where "YYY" can be 108 or 144; and "ZZZ" can be MHC, MBHC or MHCB
S-Energy	S-Energy modules with 35 and 40 mm frames SABB-CCYYY-xxxZ Where "A" can be C, D, L or N; "BB" can be blank, 20, 25, 40 or 45; "CC" can be blank, 60 or 72; "YYY" can be blank, BDE, MAE, MAI, MBE, MBI, MCE or MCI; and "Z" can be V, M-10, P-10 or P-15
SEG Solar	SEG Solar with 30, 35 and 40 mm frames SEG-aYY-xxxZZ Where "a" can be blank, 6 or B; "YY" can be blank, MA, MB, PA, or PB; and "ZZ" can be blank, BB, BG, BW, HV, WB, WW, BMB, BMA-HV, BMA-BG, BMA-TB, BMB-TB, BMB-HV, BMD-HV, BMB-BG, BTA-BG or BMD-TB
Seraphim USA	Seraphim modules with 30, 35 and 40 mm frames SRP-xxx-YYY-ZZ Where "xxx" is the module power rating; and "YYY" can be BMA, BMD, 6MA, 6MB, 6PA, 6PB, 6QA-XX-XX, and 6QB-XX-XX; ZZ is blank, BB, BG or HV
Sharp	Sharp modules with 35 and 40 mm frames NUYYxxx Where "YY" can be SA or SC
Shinsung E&G	Shinsung Modules with 35 mm frames SSVxxx-144MH
Silfab	Silfab Modules with 35 and 38 mm frames SYY-Z-xxxAb Where "YY" can be IL, SA, LA, SG or LG; "Z" can be blank, M, P, or X; "A" can be blank, B, H, M, N; and "b" can be A, C, C+, G, K, L, M, N, T, U or X

MODULE COMPATIBILITY

Sirius PV	Sirius PV Modules with 35 mm frames ELNSMzzM-HC-xxx Where "zz" can be 54 or 72
Solar4America	Solar4America modules with 30, 35 and 40 mm frames S4Axxx-YYzzAA Where "YY" can be 60, 72, 108 or 144; "zz" can be MH5 or MH10; and "AA" can be blank or BB, BW, SW or STT
Solarever	Solarever modules with 35 mm frames SE-zzz*yy-xxxM-aaa Where "zzz" can be 166 or 182; "yy" can be 83 or 91; and "aaa" can be 108, 144 or 144N
Solaria	Solaria modules with 35 and 40 mm frames PowerA-xxxY-ZZ Where "A" can be X or XT, "Y" can be R or C; and "ZZ" can be blank, AC, BD, BX, BY, PD, PL, PM, PM-AC, PX, PZ, WX or WZ
Solarcity (Tesla)	Solarcity modules with 40 mm frames SCxxxYY Where "YY" can be blank, B1 or B2
SolarTech	SolarTech modules with 40 mm frames AAA-xxxYY Where "AAA" can be PERCB-B, PERCB-W, HJT B-B, HJT B-W or STU; "YY" can be blank, PERC or HJT
SolarWorld AG	SolarWorld Sunmodule Plus, Protect, Bisun, XL, Bisun XL, may be followed by mono, poly, duo, black, bk, or clear; modules with 31 and 33 mm frames SW-xxx
SolarWorld Americas	SolarWorld Sunmodule Plus, Protect, Bisun, XL, Bisun XL, may be followed by mono, poly, duo, black, bk, or clear; modules with 33 mm frames SWA-xxx
Sonali	Sonali Modules with 35 and 40 mm frames SS-M-xxx Where "M" can be blank or M
Star Solar	Star Solar modules with 35 mm frames Star-xxxW-YYY-ZZZ Where "YYY" can be M60H or M60HB; and "ZZZ" can be blank or M10
Stion	Stion Thin film modules with 35 mm frames STO-xxx or STO-xxxA
SunEdison	SunEdison Modules with 35 and 40 mm frames SE-YxxxZABCDE Where "Y" can be B, F, H, P, R, or Z; "Z" can be 0 or 4; "A" can be B,C,D,E,H,I,J,K,L,M, or N; "B" can be B or W; "C" can be A or C; "D" can be 3, 7, 8, or 9; and "E" can be 0, 1 or 2
Suniva	Suniva modules with 35, 38 and 40 mm frames OPTxxx-AA-B-YYY-Z MVXxxx-AA-B-YYY-Z Where "AA" is either 60 or 72; "B" is either 4 or 5; "YYY" is either 100,101,700,1B0, or 1B1; and "Z" is blank or B
Sunmac Solar	Sunmac modules with 30 and 35 mm frames SMxxxMaaaZZ-YY Where "aaa" can be 660, 754 or 772; "ZZ" can be NH or SH; and "YY" can be BB or TB
Sunpower	Sunpower standard (G3 or G4) or InvisiMount (G5) 35 and 40 mm frames SPR-Zb-xxx-YY Where "Z" can be A, E, M, P or X; "b" can be blank, 17, 18, 19, 20, 21, or 22; and "YY" can be blank, BLK, COM, C-AC, D-AC, E-AC, BLK-E-AC, G-AC, BLK-G-AC, H-AC, BLK-H-AC, BLK-C-AC, or BLK-D-AC

MODULE COMPATIBILITY

Sunspark	Sunspark modules with 40 mm frames SYY-xxxZ-A Where "YY" can be MX or ST; and "Z" can be M, MB, M3, M3B, P or W; and "A" can be 60 or 72
Suntech	Suntech modules with 35 and 40 mm frames STPxxxy-zz/aa Where "y" is blank or S; and "zz" can be 20, 24, A60, A72U, B60 or B72; and "aa" can be Vd, Vem, Vfw, VfH, Vnh, Wdb, Wde, Wd, WfHb or Wnhb
Talesun	Talesun modules with 30, 35 and 40 mm frames TAByZZaa-xxx-b Where "A" can be D or P; "B" can be 6 or 7; "y" can be blank, F, G, H, I or L; "ZZ" can be 54, 60, 66, 72 or 78; "aa" can be M, M(H), or P; and "b" can be blank, B, T, or (H)
Tesla	Tesla modules with 40 mm frames TxxxY Where "Y" can be H or S
Thornova	Thornova Modules with 30 and 35 mm frames TS-YYZZ(xxx)-X Where "YY" can be BB, BG or BGT; "ZZ" can be 54, 60 or 72; and "X" can be blank or X
Trina	Trina Modules with 30, 35 and 40 mm frames TSM-xxxYYZZ Where "YY" can be DD05, DD06, DD14, DE14, DE15, DE15V, DEG15, DEG15VC, DE18M, DEG18MC, DE09, DE19, DEG19C.20, DE06X, PA05, PC05, PD05, PD06, PA14, PC14, PD14, PE14, PE15, NEG19RC or NE09RC ; and "ZZ" can be blank, .05, .05(II), .08, .08(II), .10, .18, .08D, .18D, 0.82, .002, .00S, 05S, 08S, .20, .20(II), A, A.05, A.08, A.10, A.18, (II), A(II), A.05(II), A.08(II), A.082(II), A.10(II), A.18(II), C.05, C.07, C.05(II), C.07(II), H, H(II), H.05(II), H.08(II), HC.20(II), HC.20(II), M, M(II), M.05(II), MC.20(II)
Universal	Universal Solar modules with 35 mm frames UNI-xxx-yyyZZZ-aa Where "yyy" can be 108, 120 or 144; "ZZZ" can be M, MH, BMH; and "aa" can be blank, BB or DG
URE	URE modules with 35 mm frames DyZxxxxaa Where "D" can be D or F, "y" can be A, B, 6 or 7; "Z" can be K, L or M; and "aa" can be C8G, H3A, H4A, H8A, L4A, E7G-BB, E8G, E8G-BB, MFG, MFG-BB or M7G-BB
Vikram	Vikram solar modules with 35 and 40 mm frames XVSyy.ZZ.AAA.bb Where "X" can be blank, Paradea, Prexos or Somera; "yy" can be M, P, MBB, MDH, MDHT, MH, MS, MHBB, or PBB; "ZZ" can be 54, 60 or 72; "AAA" is the module power rating; and "bb" can be 03, 04 or 05
VSUN	VSUN modules with 30, 35 and 40 mm frames VSUNxxxA-YYz-aa Where "A" can be blank or N; "YY" can be 60, 72, 108, 120, 132, 144; "z" can be M, P, MH, PH, or BMH; and "aa" can be blank, BB, BW, or DG
Waaree	Waaree modules with 35 and 40 mm frames AAyy-xxx Where "AA" can be WS or Bi; and "yy" can be blank, M, MB, MD, MDI, MDIB, 33, 55, 57 or 66
Winaico	Winaico modules with 35 and 40 mm frames Wsy-xxxZa Where "y" can be either P or T; "Z" can be either M, P, or MX; and "a" can be blank or 6

MODULE COMPATIBILITY

Yingli	Yingli modules with 30, 35 and 40 mm frames YLxxxZ-yy Where "Z" can be D or P; "yy" can be blank, 29b, 30b, 34d, 35b, 36b, 37e 1/2, 37e 1500V 1/2, 40d, 49e 1/2 or 49e 1500V 1/2
Yotta	Yotta modules with 30 and 35 mm frames YSM-Bxxx-ZZ-72-1 Where "ZZ" can be 06 or 10
Zeus	Zeus Solar Modules with 40 mm frames ZxxxM-HB
ZN Shine	ZN Shine modules with 30 and 35 mm frames ZXMY-AAA-xxx/M Where "Y" can be 6, 7 or 8; "AAA" can be 72, NH120, NH144, NHDB144, NHLDD144, SH108, SH144, SHDB144, SHLDD144 or TP120