



aPbox Installation and Operations Manual

Version 1.1

Issued on: December 22, 2022

©2022 FranklinWH Energy Storage Inc. All rights reserved.

All information in this Manual is subject to the copyright and other intellectual property rights of FranklinWH Energy Storage Inc. This manual may not be modified, copied or reproduced, in whole or in part, without the prior written permission of FranklinWH Energy Storage Inc.

Please visit www.franklinwh.com/support for the latest Franklin Home Power documents.

All brands and trademarks mentioned in this document are the property of their respective owners, and their use in this document does not imply the sponsorship or recognition of their products or services.

Please read this document carefully to ensure the best reliability of the product and your warranty eligibility. For further information about warranty, please refer to the **Franklin Home Power Limited Warranty**.

This document is intended for use by professional installation and maintenance service providers only and no statements, information or recommendations in this document constitute any express or implied warranty.



Please read this document carefully before installing or using the Franklin Home Power equipment. Failure to follow any instructions or warnings in this document may result in damage to the equipment, personal electric shock, severe injury, or even death.

Product Information

The FranklinWH aPbox provides the functions of an electrical meter and the ability to remotely disconnect from and connect to PV systems, controlled by the aGate X.

FranklinWH Energy Storage Inc. ("FranklinWH") reserves the right to make any improvements to the product, and the contents in this document shall be subject to updates without further notification.

All images and pictures provided in this manual are only for demonstration purposes and may differ in detail from the product, based on the product version.

FCC Compliance

This equipment has been tested and found to comply with the limits for a Class B digital device, pursuant to part 15 of the FCC Rules. These limits are designed to provide reasonable protection against harmful interference in a residential installation. This equipment generates, uses and can radiate radio frequency energy and, if not installed and used in accordance with the instructions, may cause harmful interference to radio communications. However, there is no guarantee that interference will not occur in a particular installation. If this equipment does cause harmful interference to radio or television reception, which can be determined by turning the equipment off and on, the user is encouraged to try to correct the interference by one or more of the following measures:

- Reorient or relocate the receiving antenna.
- Increase the separation between the equipment and receiver.
- Connect the equipment into an outlet on a circuit different from that to which the receiver is connected.
- Consult the dealer or an experienced radio/TV technician for help.

MPE caution (if a FCC certified RF module is inserted in & the separation distance is indicated in the FCC grant of RF module)

To satisfy FCC / IC RF exposure requirements, a separation distance of 8 inches (20 cm) or more should be maintained between the antenna of this device and persons during device operation.

To ensure compliance, operations at closer than this distance is not recommended.

Feedback

If you have any questions or comments, please send us an email at: service@franklinwh.com

Disposal of Scrapped Products

Scrapped products (including their internal chemicals and electrical materials) should not be disposed of with household wastes. Please refer to your local laws and regulations regarding disposal.



CONTENT

Safety Statements.....	1
Important Information	1
Safety Symbols	1
Safety Instructions.....	2
Warranty Statement.....	4
Service and Maintenance	5
Service.....	5
Maintenance	5
Product Overview.....	6
Specifications.....	6
Components.....	7
Application	8
PV on the load side of the FHP.....	9
PV on the line side of the FHP	10
aPbox Installation	11
Preparation.....	11
Installation	12
Unboxing.....	12
Open the aPbox door	13
Cable Access	14
aPbox wall installation.....	16
Wiring.....	18
Make AC power connections	18
Communications connections	20
App settings	24
Add aPbox accessories.....	24

aPbox Setting..... 26

Technical Support..... 28





Safety Statements

Important Information

The FranklinWH aPbox is an electrical device. Please read this entire document to ensure proper use. Failure to follow this may void the warranty. Please strictly follow the safety instructions described in this manual during operation, otherwise it may result in equipment malfunction, electrical shock, serious injury or death.

Safety Symbols

This Manual contains the following safety symbols.

	DANGER: This indicates a hazardous situation which, if not avoided, may result in death or serious injury.
	WARNING: This indicates a situation where failure to follow instructions may be a safety hazard or cause equipment malfunction. Use extreme caution and follow instructions carefully.
	NOTE: This indicates information that is important for optimal system operation. Closely follow instructions.
	ELECTRONIC DEVICE: DO NOT THROW AWAY! All scrapped products (including their internal chemicals and electrical materials) should not be disposed of with household wastes. Please refer to your local laws and regulations regarding disposal.









* The DANGER, WARNING, and NOTE alerts are supplemental to the safety instructions and are not exhaustive.

Safety Instructions

General Information

	The aPbox is electrical equipment that, when used improperly, can present a risk of electrical shock and fire, and misuse may void the warranty. Only FranklinWH certified and qualified electricians should install, maintain or replace the equipment or wiring. Workers must wear personal protective equipment (PPE) during operation.
	The aPbox should be installed away from heating equipment, or any source of heat and/or fire.
	It is strictly forbidden to install, maintain or handle aPbox units outdoors during bad weather such as thunder, rain, snow and high winds.
	It is strictly forbidden to work on or operate an aPbox alone. For safety, make sure that there is someone around you who can help.
	When installing and maintaining an aPbox, avoid any foreign objects being inserted or dropped into the enclosure.
	To prevent misoperation, ensure that the upstream and downstream switches are disconnected and padlocked during installation or maintenance.
	During the transport and handling of an aPbox, extreme care is required to avoid dropping, bumping, stomping, or inverting the equipment.
	Only use parts or accessories purchased from FranklinWH or a FranklinWH-certified party.
	Do not paint any part of the aPbox unless the paint surface of the equipment housing is accidentally damaged during transport, installation or maintenance. The damaged part can be repaired with paint or topcoat of the same color.
	If any equipment failure occurs, please contact your installer or after-sales service provider for support. Do not attempt to take apart, repair and/or modify an aPbox without the authorization of FranklinWH. Otherwise, it may lead to safety hazards and void your warranty.
	Do not use an aPbox if there is functional or cosmetic damage noticed after unboxing (except for slight paint damage). Contact after-sales service for support.
	The installation, wiring, maintenance, transportation, and handling of the aPbox should follow local laws, regulations and standards, and the Safety Instructions in this Guide serve as supplementation to the laws, regulations and standards.

During the installation, use, storage, and transport of equipment:

	DANGER: Keep away from flammable and explosive materials.
	DANGER: Additional protective measures should be taken to protect equipment from access by children.
	WARNING: Install in dry, cool and well-ventilated location for satisfactory performance.
	WARNING: Install away from standing water or from areas that can pool water.
	WARNING: Keep away from dust and smoke.
	WARNING: Install where there is no direct exposure to sunshine, rain or snow.
	WARNING: Keep way from water sources including downspouts, sprinklers, faucets and liquid containers.
	WARNING: If wall-mounted, ensure sufficient bearing capacity.
	WARNING: This product can expose you to lead, which is known to the State of California to cause cancer, birth defects or other reproductive harm. (For more information go to www.p65warnings.ca.gov).

Warranty Statement

To meet warranty requirements, FranklinWH aPbox products must be installed and operated properly according to the instructions in related FranklinWH documents.

To secure the full warranty, the FranklinWH aPbox products must be reliably connected to Franklin Home Power (FHP) system to access remote services provided by FranklinWH.

Please visit us at www.franklinwh.com/support to learn more about the warranty.

Service and Maintenance

Service

- Keep the equipment away from leaves or other foreign materials, especially keep objects from the top of the unit and keep the space clear between the unit and the back wall.
- Keep the equipment away from direct sunlight.
- Keep all equipment in an environment with acceptable temperature and humidity.
- Clean the equipment surface using a soft cloth. If water is needed, please make sure the cloth is slightly damp (water only) and the equipment is completely de-energized.
- Don't block the vents.
- Keep the equipment away from flammable, explosive, and/or poisonous materials.
- Keep the equipment operating within the allowed power range and avoid overloading.
- Make sure all cables are wired reliably and all connectors are free of stress.
- Keep the equipment away from hazardous zones and potential risks.
- A nearby smoke detector is recommended if the equipment is installed indoors.

Maintenance

- Please check the running status of your equipment on your mobile app. If any alarm is found, please contact the qualified service group.
- Never attempt to repair the system by yourself. Contact professionals certified by FranklinWH.

Product Overview



The aPbox can be used to measure the amount of electricity generated by a PV system, and can also be used as a disconnect to sever the connection to the PV system when the photovoltaic over-generation is triggered. It supports access of up to two PV systems with a total current of no more than 65A.

Specifications

Electrical Specifications	
Nominal Voltage	120/240VAC, split
Frequency	60 Hz
Rated Output Current	1 circuit, max 65A
Rated Input Current	2 circuits, max 65A total
Mechanical Specifications	
Dimensions (W x H x D)	11.8 in. x 17.7 in. x 5.9 in. (300mm x 450mm x 150mm)
Weight	21.2 lbs. (9.6kg)
Mounting Options	Wall mount (Indoors/Outdoors)
Environmental Specifications	
Operating Temperature Range	-4°F~122°F (-20°C~50°C)
Storage Temperature Range	-22°F~140°F (-30°C~60°C)
Operating Humidity (RH)	0~100%
Maximum Altitude	9843 feet (3000 meters)
Type of Enclosure	NEMA 3R
Compliance Information	
Compliance	FCC 

Components

The aPbox includes the following components and features.

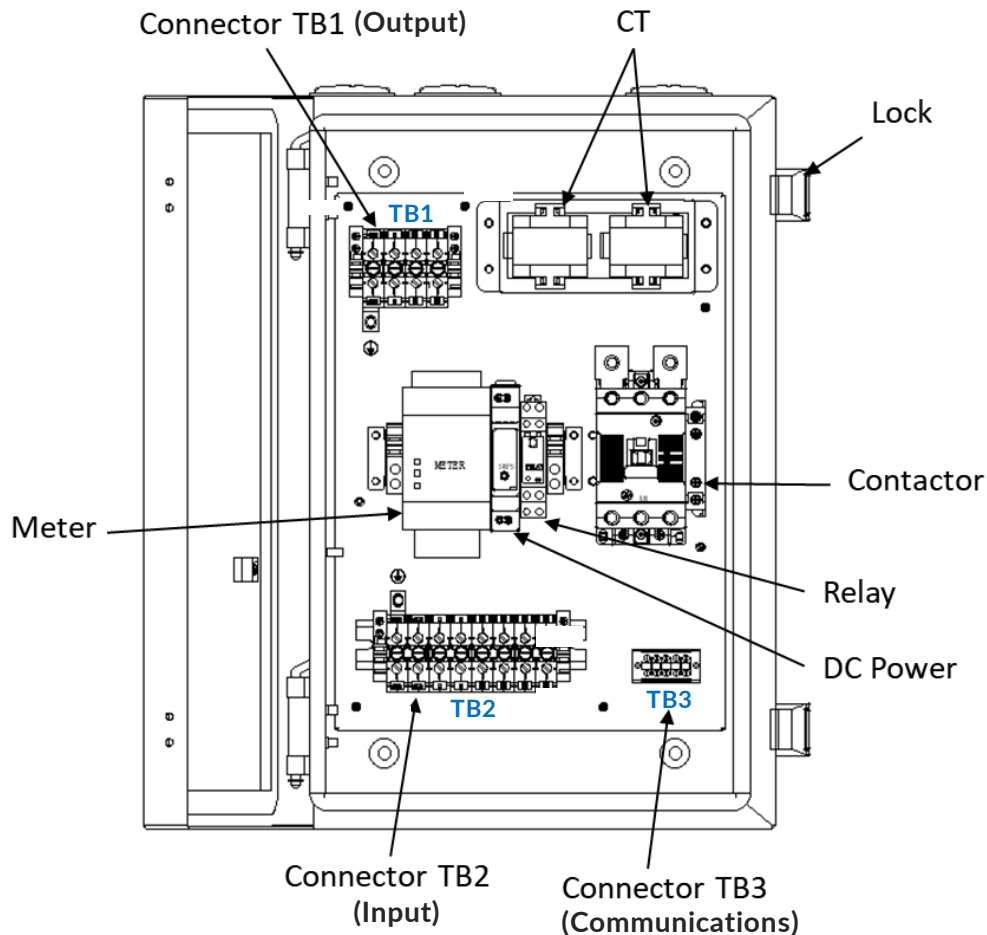

- **Control System:** Consisting of a DC Power, a relay and a contactor, executing the command from the aGate X that allows the aPbox to disconnect from or reconnect to the PV system.
- **Metering System:** Metering the PV production by a built-in meter and CTs. The CTs collect current data from the PV system and forward that data to the meter for analysis and reporting to the aGate X.
- **Connectors:** The wiring connector including TB1, TB2 and TB3. TB1 is connected to the grid (or an equivalent AC power). TB2 is connected to the PV system and TB3 is connected to the aGate X for communications.

Application

While the aGate X has a PV breaker as an optional component, there are some situations in which the PV system cannot be connected through the breaker or where there are multiple PV connections needed. In those instances, an aPbox can be used to connect the solar source to the aGate X or the grid.

There are two scenarios that define how the external connections with an aPbox are connected.

PV on the load side of the FHP

Installation of an aPbox is required to meter the production of and cutoff the connection to an individual PV system installed on the load side of the FHP system due to:

- Existing constraints, such as the location of the PV system and the aGate X, preventing the PV system connection to the aGate X internal PV interface.
- Multiple PV systems on-site prevent a distinct PV system from being connected to the aGate X.
- The total PV system output power exceeding the power rating of the aGate X internal PV interface.
- The total amount of the PV production exceeding the aPower energy capacity.

In this scenario, one aGate X supports up to two aPbox connections. The FHP system controls the PV system connection according to whether the photovoltaic over-generation in the off-grid mode.

The example site layout is shown in the following figure.

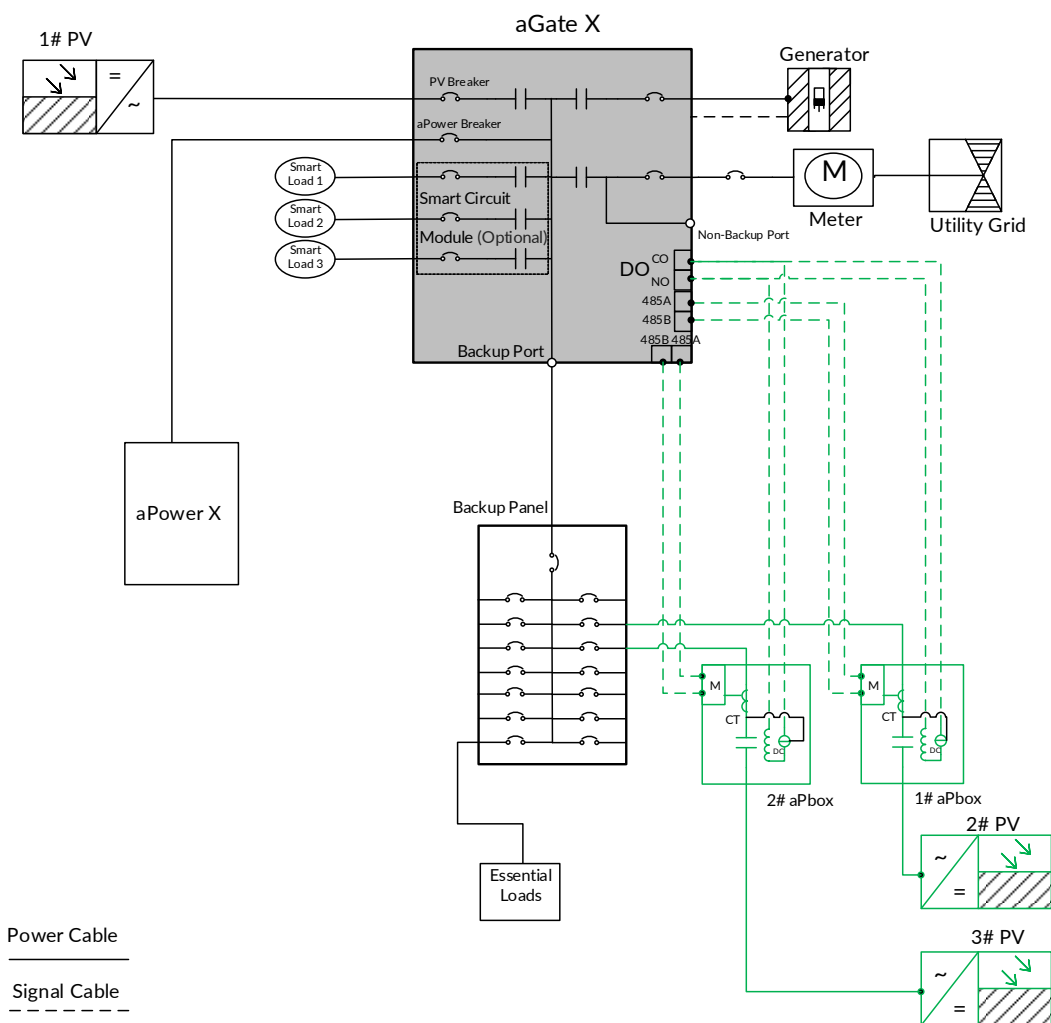

PV on the line side of the FHP

The installation of an aPbox is to monitor the generation of the PV system and provide data to the FHP system.

In this scenario, one aGate X only supports one aPbox connection.



NOTE

When there is a grid outage, the separated PV system will disconnect from the grid and shut down.

The example site layout is shown in the following figure.

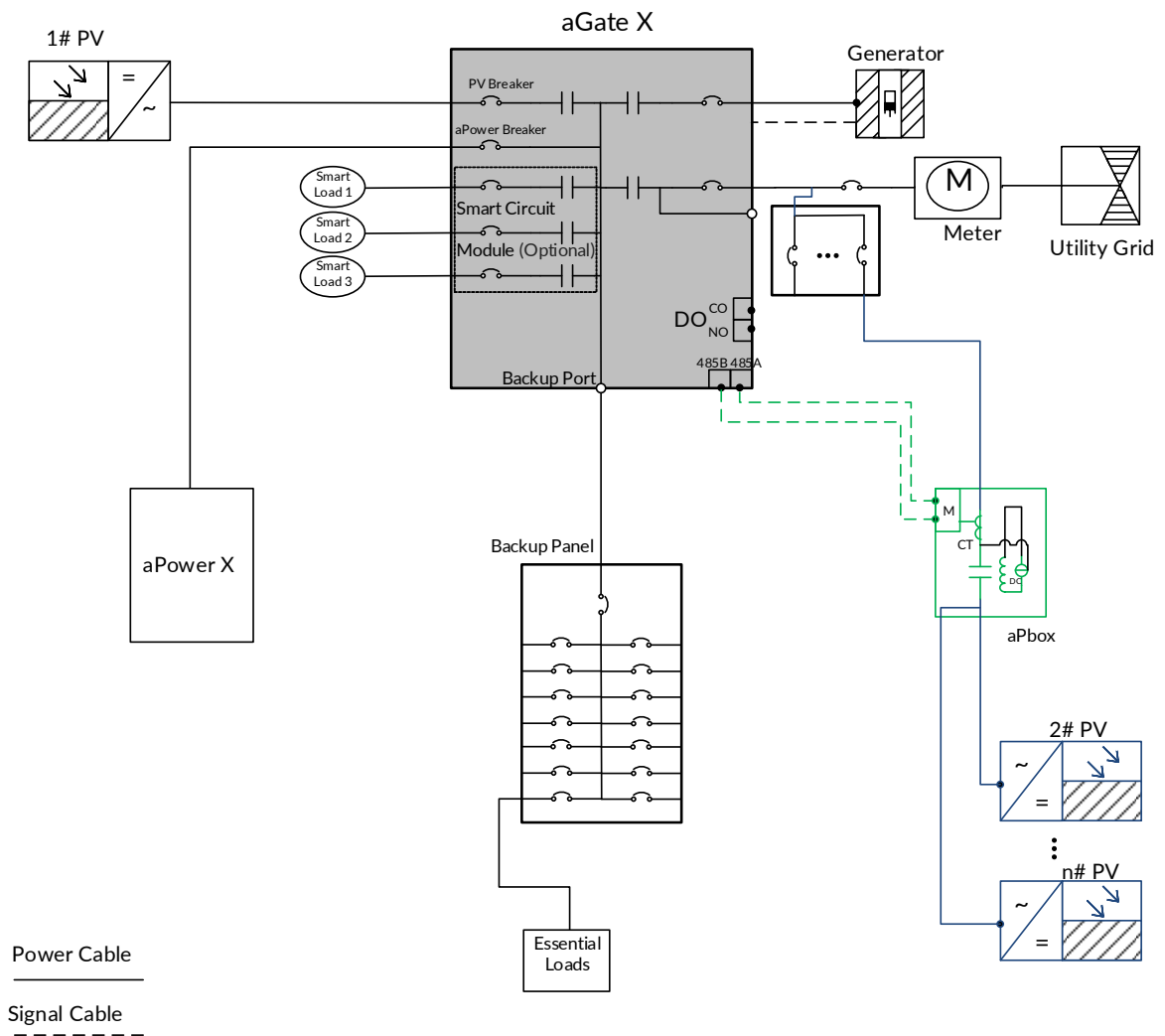

aPbox Installation

Preparation

Ensure that you have the following before installation:

- **Personal protective equipment (Safety glasses, gloves, protective shoes, dust masks)**
- **Electric drill with**
 - o 5/32" Brad Point Bits or 5/32" twist drill bits for drilling mounting holes in wooden walls.
 - o 1/2", 3/4", 1", 1-1/2", 2" wood drill bits for drilling cable conduits in wooden walls.
 - o 1/2", 3/4", 1", 1-1/2", 2" hole saw drills for drilling cable conduits in masonry or concrete walls.
- **Hammer drill with**
 - o 1/2", 3/8" Masonry Bits for drilling mounting holes in masonry or concrete walls.
 - o 1/2", 3/8", 3/4", 1", 1-1/2", 2" diamond core drills for drilling cable conduits in masonry or concrete walls.
- **Socket wrench, extension bar and 4pcs 1/4" expansion bolts**

The tools is for installing expansion bolts.
- **Torque wrench**

With various slotted screwdriver heads for mounting the aPbox on the wall connector cables and checking torque.
- **Torque wrench extension rod**

6" (150mm) and more extension rod to mount the aPbox on the wall.
- **Utility knife**

Used for unboxing.
- **Wiring tools**

Wire stripper, Wire cutter, Utility wire shear
- **Stud finder**

Detects the location of the wires in the wall to prevent short circuits before drilling
- **Multimeter**

Used to measure the voltage and current.
- **Work light**

For lighting during power-off
- **Spirit level**

Used to the aPbox is level.
- **Marker**

Marks the mounting hole location.
- **Camera**

Records the installation process.
- **Deep Cut Band Saw**

For thin-walled steel pipe or PVC pipe cutting.
- **Knockout Tool Kit**

Used to enlarge the hole or to make new holes when the conduit diameter is larger than the aPbox knockout hole, or if any new hole needs to be made.

Installation

The length of the communications wire between the aGate X and the aPbox should not exceed 328 feet (100 meters).

Unboxing

Step 1 Inspect the packaging for damage.

Step 2 Use a retractable utility knife to cut open the sealing tape of the package box, with the knife blade shorter than 0.3 inch to avoid damaging the aPbox case.

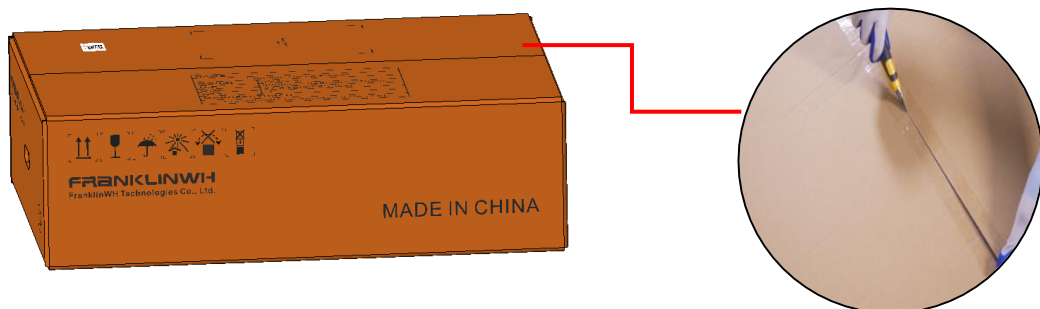

Step 3 Remove the box contents and check for the following items:

- One aPbox
- One mounting template
- One accessory bag including the following:
 - i. Four 1/4" water-tight washers
 - ii. Ten cable ties
 - iii. Two keys



NOTE

- Save the mounting template for marking the mounting holes.
 - During handling and installation, make sure the aPbox is well protected to avoid scratches or damage.
-

Step 4 Remove the buffer foam and PE bag wrapping the aPbox.

Open the aPbox door

Use the key from the accessory bag to open the clasp locks, release the clasp and open the door, as shown in the following figure.

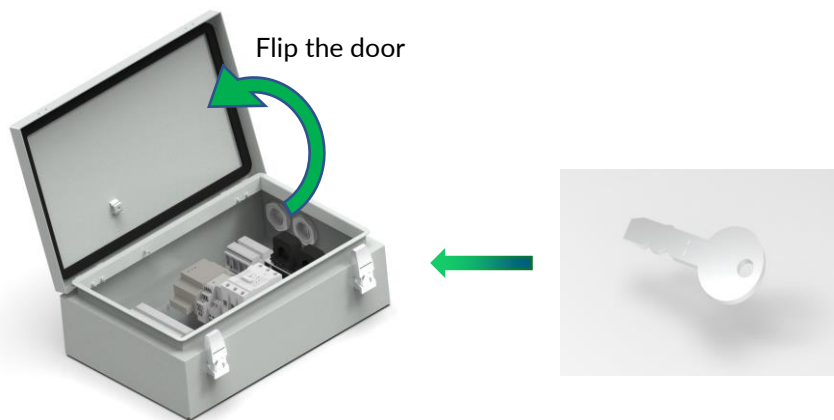

Cable Access

Based on the preplanned installation position and electric conduit arrangements, choose which knockouts and plugs in the aPbox should be removed.

Remove the plugs

Open the door, then turn the selected plug nut counterclockwise by hand, until the nut is removed. Then remove the plug.

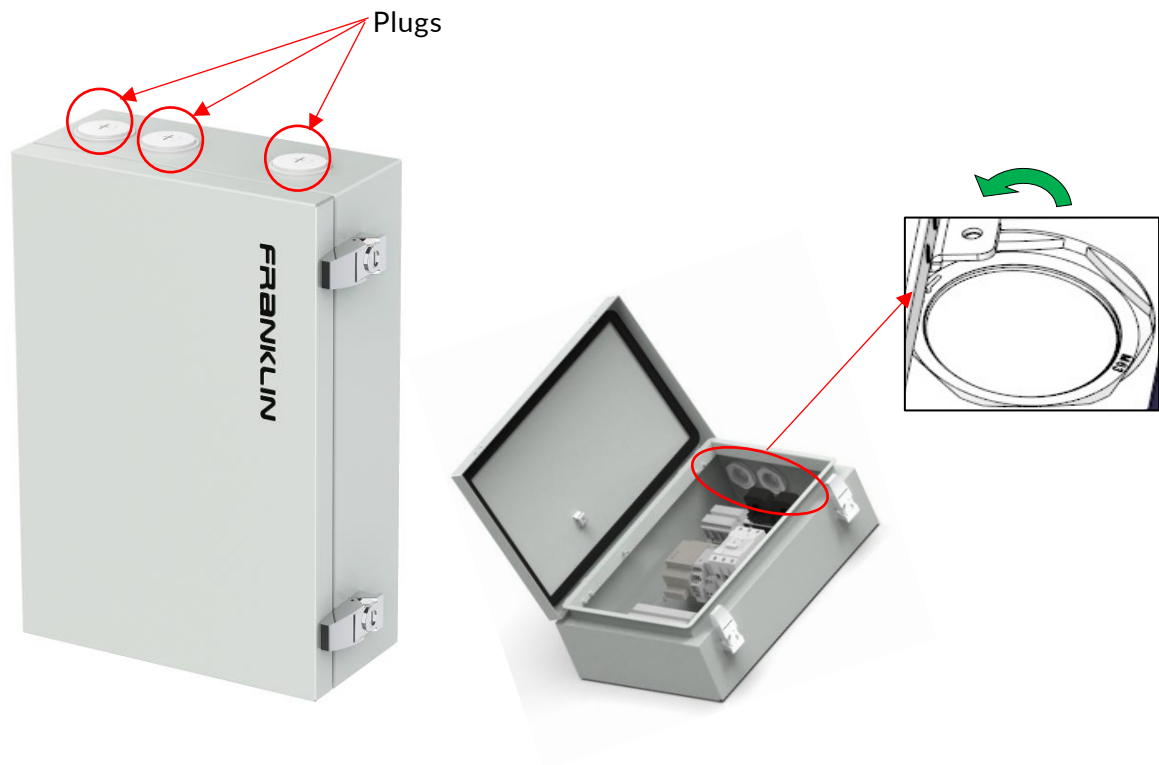

Remove the knockouts

- Step 1** Place a 1/4"X4" straight screwdriver against the black spot printed on the knockout hole, and then knock it with a hammer. Hammer until the knockout plug is angled out.

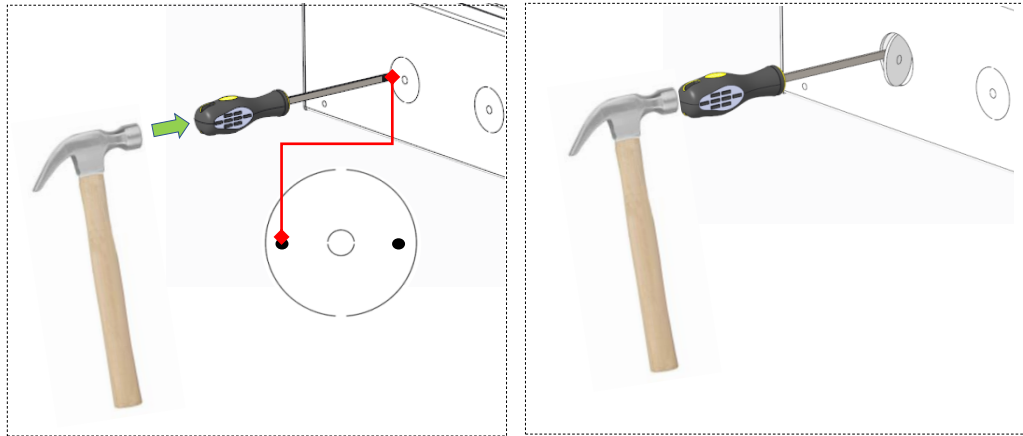

- Step 2** Using a needle-nose plier, twist the plug back and forth until the attachment points snap.

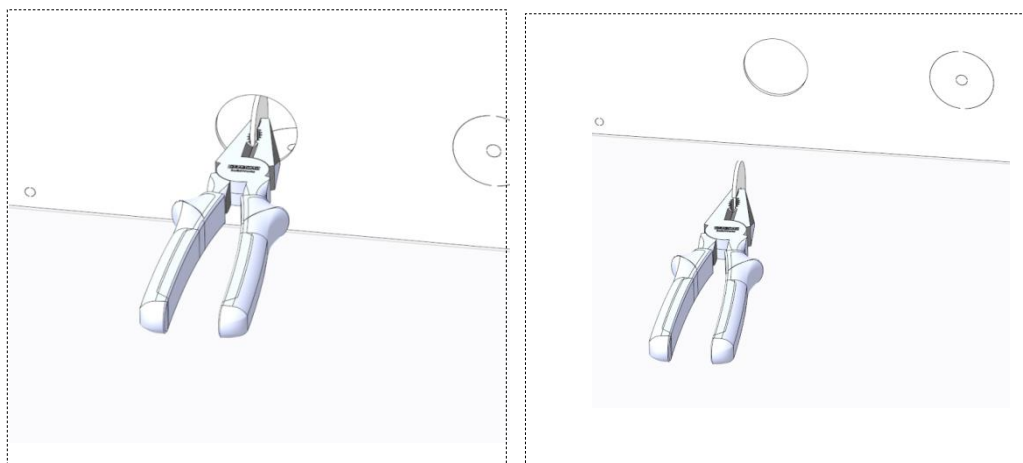

- Step 3** Dislodge the rest of the knockout. If burrs remain, remove them with a deburring tool.

aPbox wall installation

Follow the steps below to mount the aPbox on the wall.

- Step 1** Place the guide board at the planned installation position (refer to the local laws, regulations and codes for building construction to set the minimum height of aPbox). Use a spirit level to adjust the guide board, and then make marks at the four holes on the guide board.

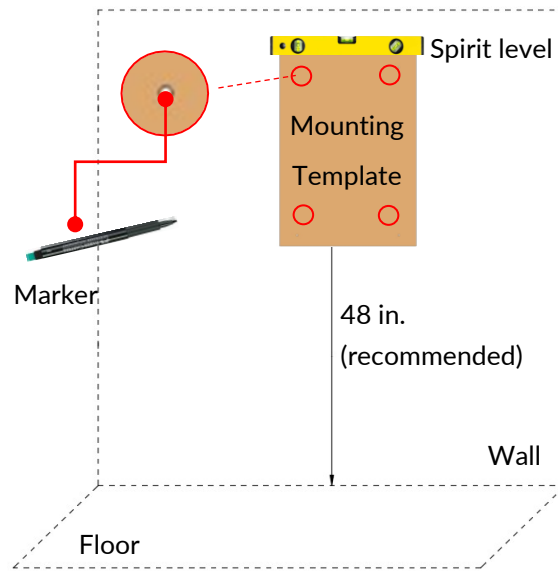

- Step 2** Using a hammer drill and the appropriate drill bits for the wall material (See [Preparation](#)), drill a hole the same diameter as the anchor diameter, and at least 1-1/2" deeper than the expected embedment. Ensure that all fasteners are at least 1.5 in (38 mm) away from the edges of masonry blocks or bricks. Clean debris out the holes.



DANGER

Do not drill electrical wires or pipes that are in the wall.

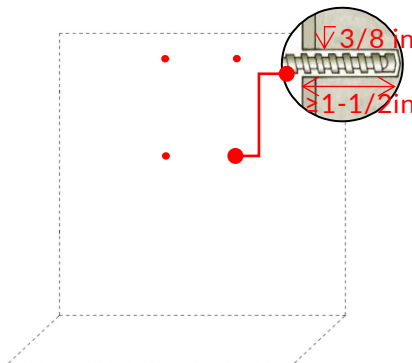

Step 3 Set the nut flush with the top of the sleeve anchor. Then, use a hammer to drive the sleeve anchor into the hole in the base material until the washer and nut are tight against the fixture. Use a 7/16" wrench to turn the nut in the counterclockwise direction, and remove the nut, spring washer, and flat washer from the sleeve anchor.

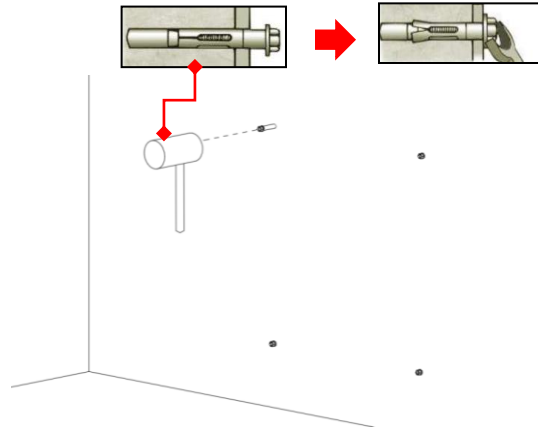

Step 4 Fasten the aPbox to the wall using the 1/4" water-tight washers (from the accessory bag), spring washers, and nuts in sequence. Use a torque wrench with an extension rod to check that the torque is 4.42 foot pounds.



NOTE

- Make sure that there is at least 0.24 in. (6mm) clearance between the aPbox unit and the wall in accordance with the NEC.

The following figure shows mounting of an aPbox.

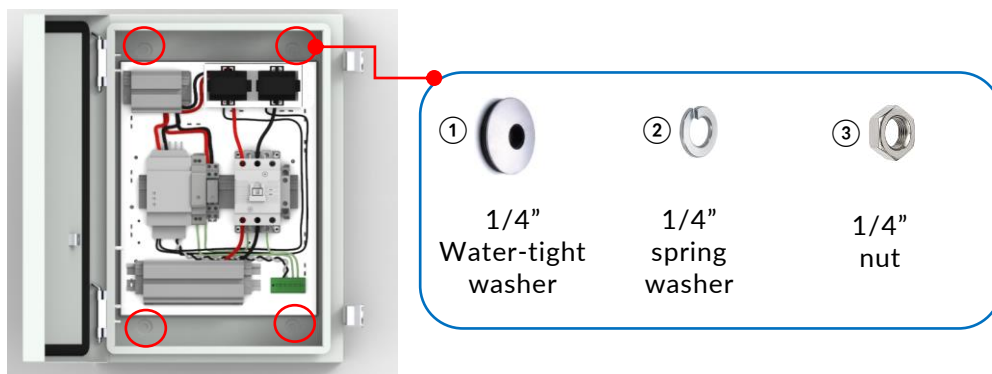

Wiring



DANGER

Before wiring, check that all circuits to be connected to the aPbox are completely de-energized, and lock out any associated circuits breakers and disconnect switches.

Make AC power connections



NOTE

- TB1 must be connected to the grid or an equivalent 240 Volt, 60Hz AC power source.
- TB2 must be connected to the PV system(s). TB2 supports up to two PV system connections.
- Incorrect wiring of AC power conductors presents a risk of electrical shock or damage to equipment. Before connecting power, ensure all connections are made according to the instructions in this document and in accordance with all local wiring codes and regulations.
- Always connect an aPbox with two phase wires, one neutral, one ground.
- Protection devices, such as circuit breakers and fuses, should be installed upstream of the TB1, the amperage of which should be depending on the site requirements and in accordance with NEC and local codes and regulations.
- Cut and strip the wires outside the aPbox enclosure and make sure no copper wires or powder remain in the box.

Use copper wires rated at 167°F (75°C) or 194°F (90°C), depending on the requirements. Connect the grid (or an equivalent AC power source) conductors to the TB1 terminal, and the PV conductors to the TB2 terminal.

Refer to [Table 1 aPbox Power Wiring](#) below for wiring requirements including wire gauges, torques and strip lengths.

Table 1: aPbox Power Wiring

Terminal	Wire Gauge (Copper)	Torque Lb*In (N*m)	Strip Length In (mm)
TB1	3AWG max.	30.1 (3.5)	0.6 (16)
TB2	3AWG max.	30.1 (3.5)	0.6 (16)
TB3	16-20AWG	4.5 (0.5)	0.28 (7)

Follow the steps to make AC Power Connections:

- Step 1** Run the grid (or an equivalent AC power source) wires and PV wires through the cable entry holes on the aPbox and pull them into the aPbox enclosure. Mark an appropriate length for later stripping.
- Step 2** Pull the wires out of the aPbox enclosure, cut off the wires from the marker point and strip the ends according to Table 1.

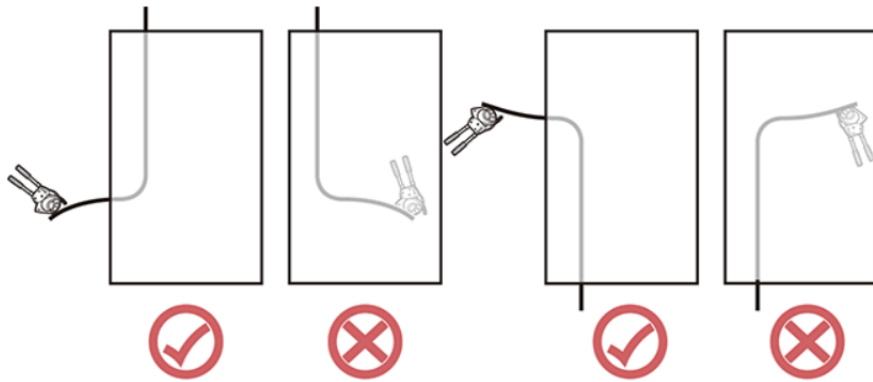

- Step 3** Insert the wires into the corresponding terminal lugs as shown in the following figure. Tighten the lugs according to Table 1 above.

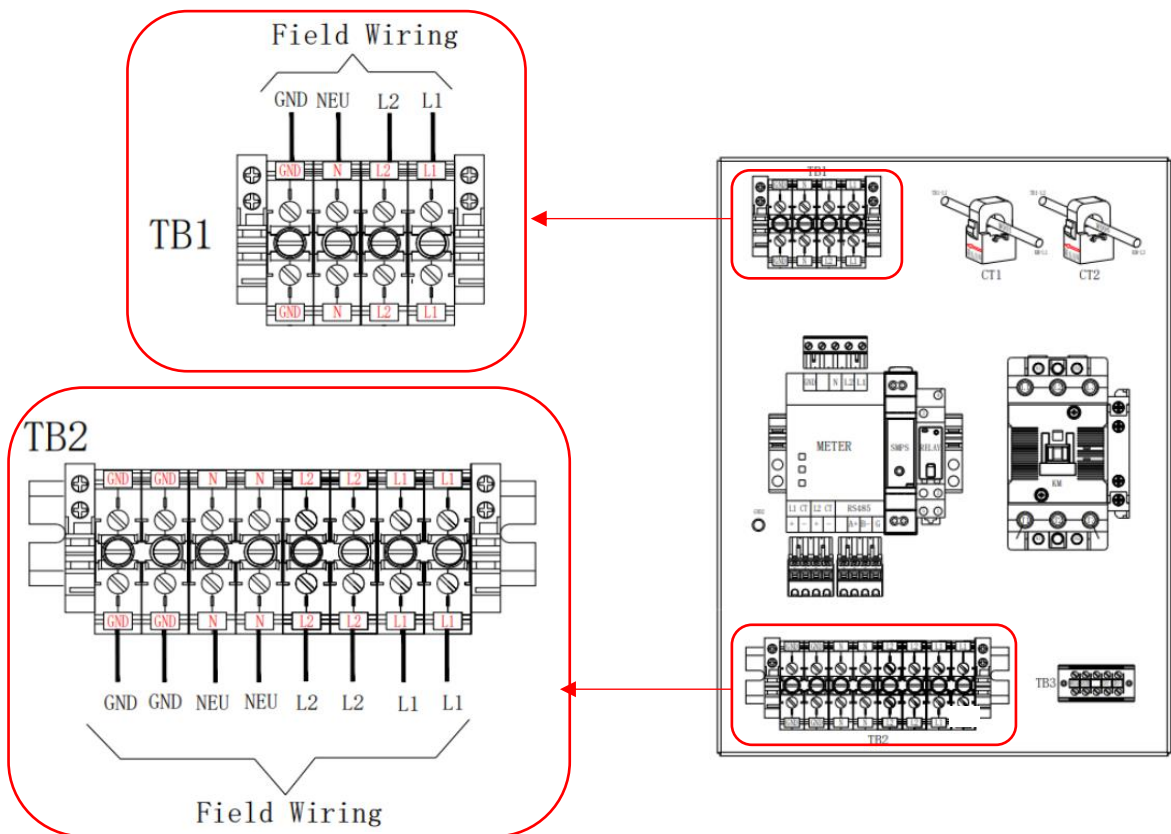

Communications connections

Connect the communications conductors to TB3 terminals. Pay attention that cutting and stripping should be carried out outside the aPbox enclosure and is prohibited inside the enclosure.

One aPbox connected to an aGate X

When one unit is connected to an aGate X, the 485A and 485B terminals on the aPbox TB3 module are connected to the RS485 A1 and B1 terminals on the aGate X, respectively, DO+ and DO- terminals to the aGate DO terminals (without distinguishing the polarity).

Use the following diagram as a reference when making communications connections.

- 1) When one aPbox is installed on the load side of the FHP system, the communications wiring figure is as follows.

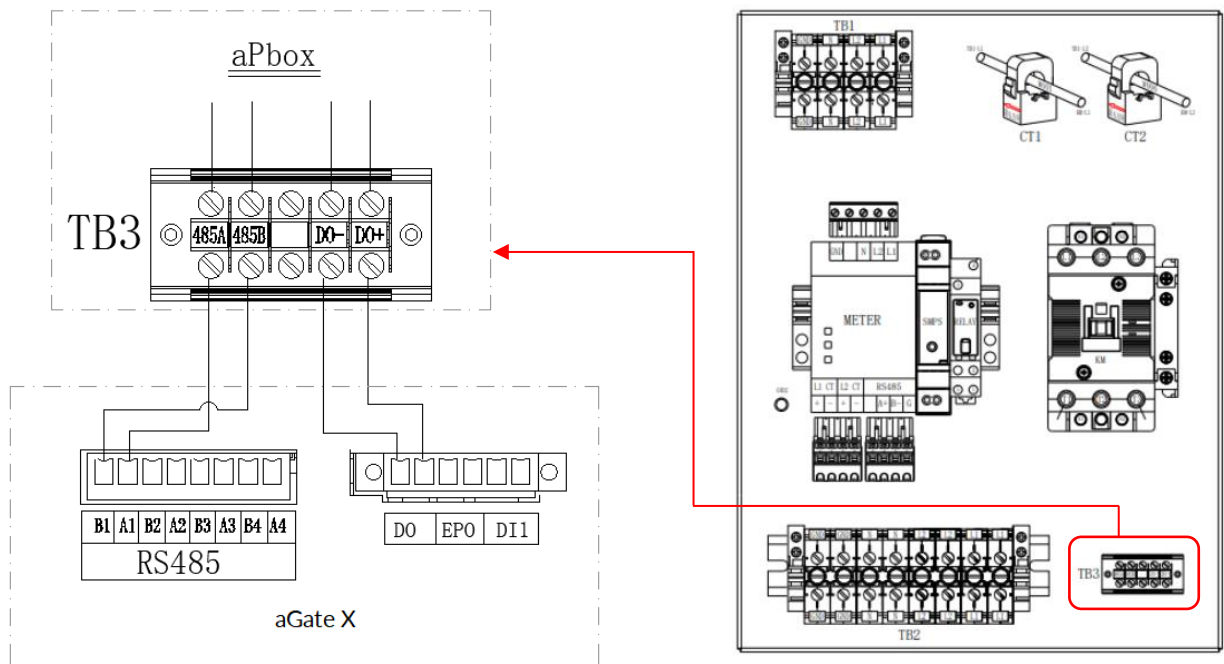

2) When one aPbox is installed on the line side of the FHP system, the communications wiring figure is as follows.

Make sure the D0- and D0+ short connector of TB3 are reliably connected, otherwise the equipment will not work properly.



NOTE

- The length of the communications cables between the aPbox and the aGate X shall not exceed 328 feet (100 meters)
- Use twisted pair cables for RS485 conductors.
- Refer to Table 1 above for wire gauge recommendations.

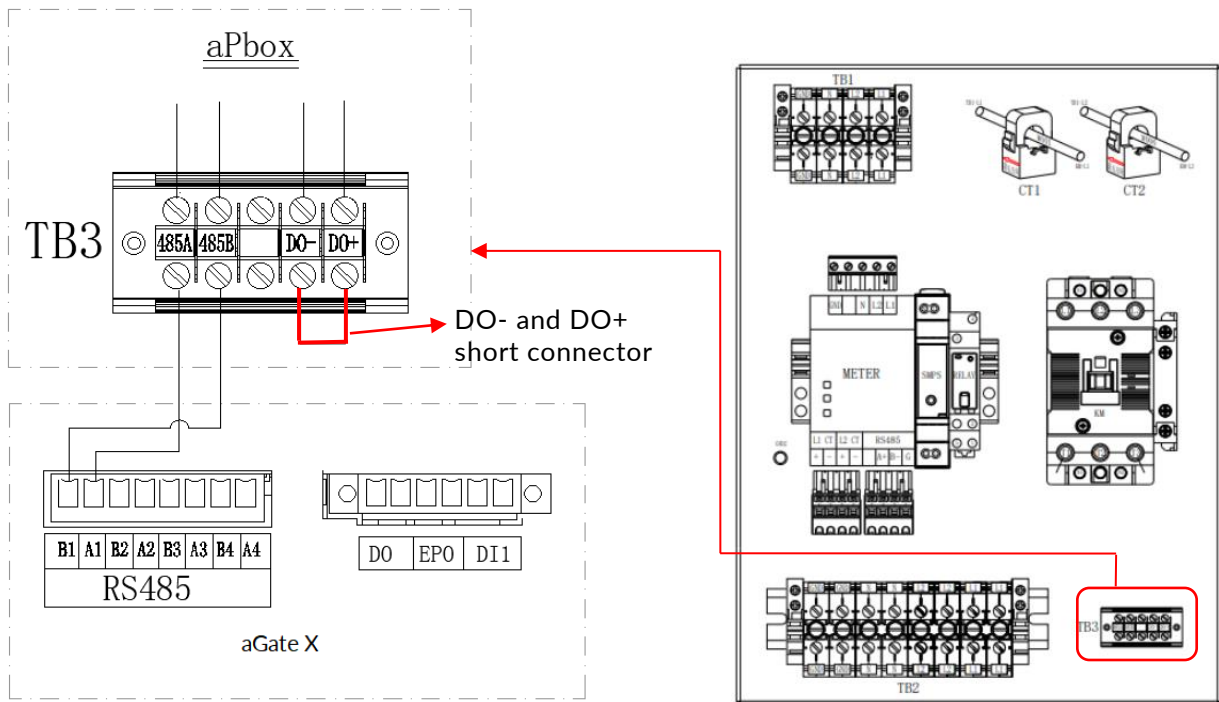

Two aPbox's connected to an aGate X

One aGate X supports up to two aPbox connections on the load side of the FHP system. When two units are connected in parallel to an aGate X:

- First aPbox
 - o TB3 485A connected to the aGate A1 terminal
 - o TB3 485B connected to the aGate B1 terminal
- Second aPbox
 - o TB3 485A connected to the aGate A2 terminal
 - o TB3 485B connected to the aGate B2 terminal

The two paralleled DO+ terminals and the two paralleled DO- terminals are connected to the aGate DO terminals (without polarity distinction), as shown in the following figure.

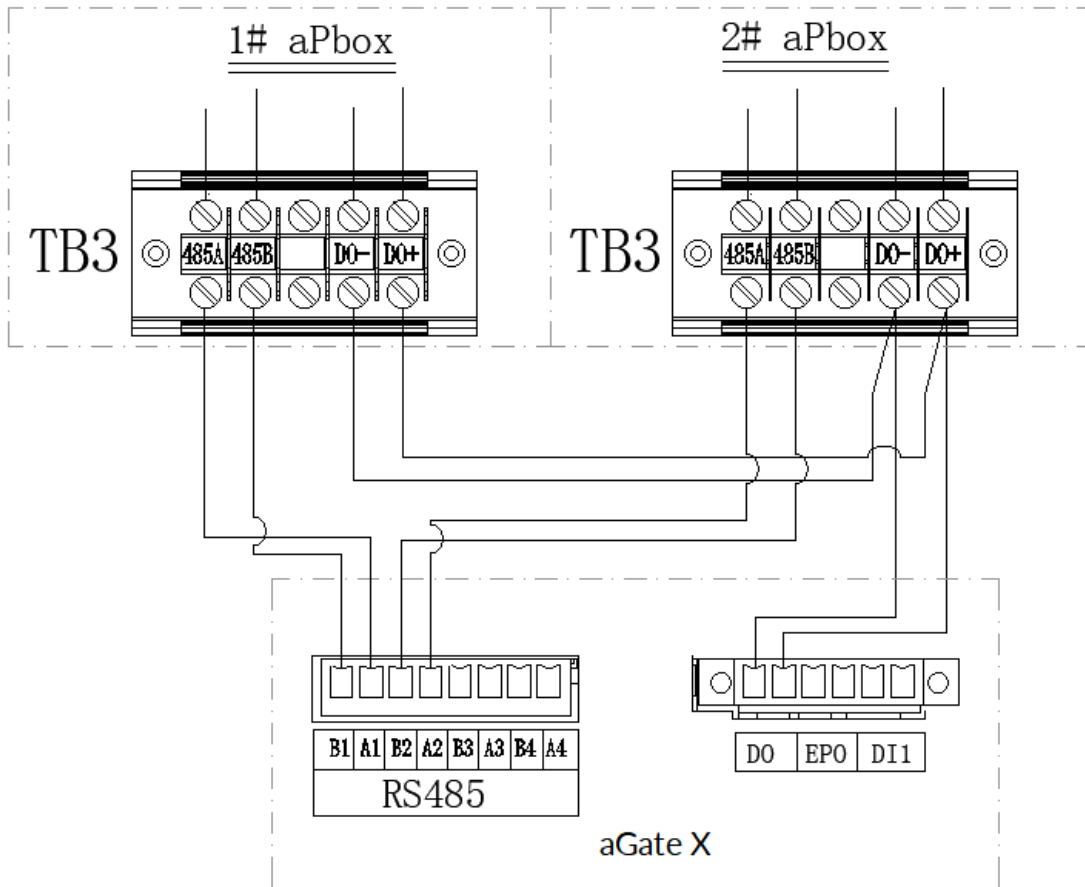

NOTE

- The length of the communications cables between the aPbox and aGate X should not exceed 328 feet (100 meters)
- Use twisted pair cables for RS485 conductors.
- The DO- DO+ terminals of the two aPbox's should be connected in parallel. Make sure that they are not interchanged with one another.
- When two units are connected to an aGate X, use 20AWG cables for DO- and DO+ conductors.

App settings

The aPbox works with the FranklinWH app. Keep the app up to date for normal operation. You can install the latest version of FranklinWH App from the Apple App Store and Google Play Store.



Follow the steps below to configure the aPbox.

Add aPbox accessories

Step 1 Login to the installer account on the app.

Step 2 Left swipe the device that you want to set, and then click "FHP Accessories".

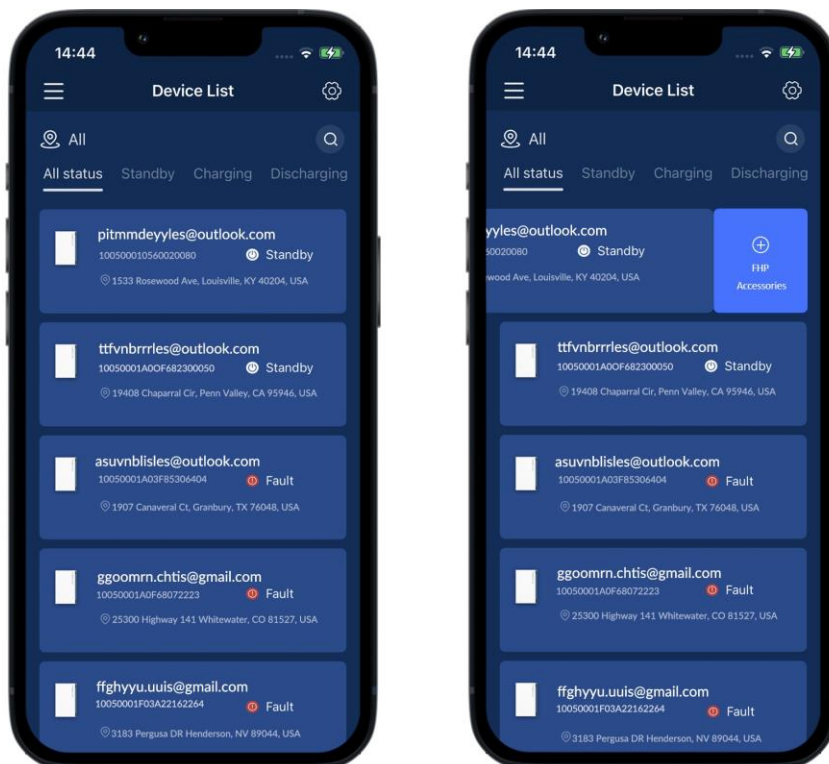

Step 3 Click "Add Accessory" to add aPbox accessories.

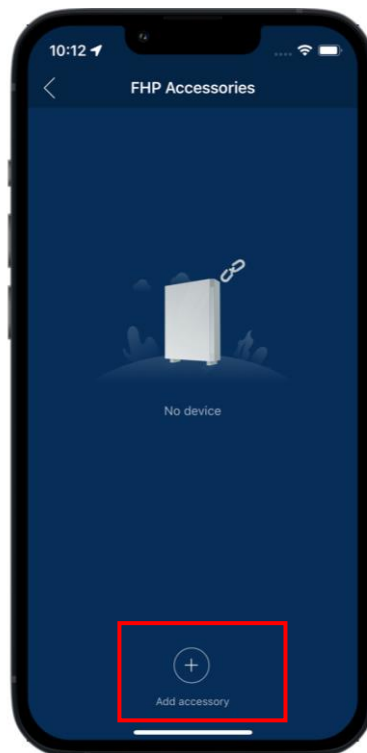

Step 4 Select "aPbox" from the drop-down box. Scan the device QR code or manually enter the "Serial number" and "Key", and click "Complete".

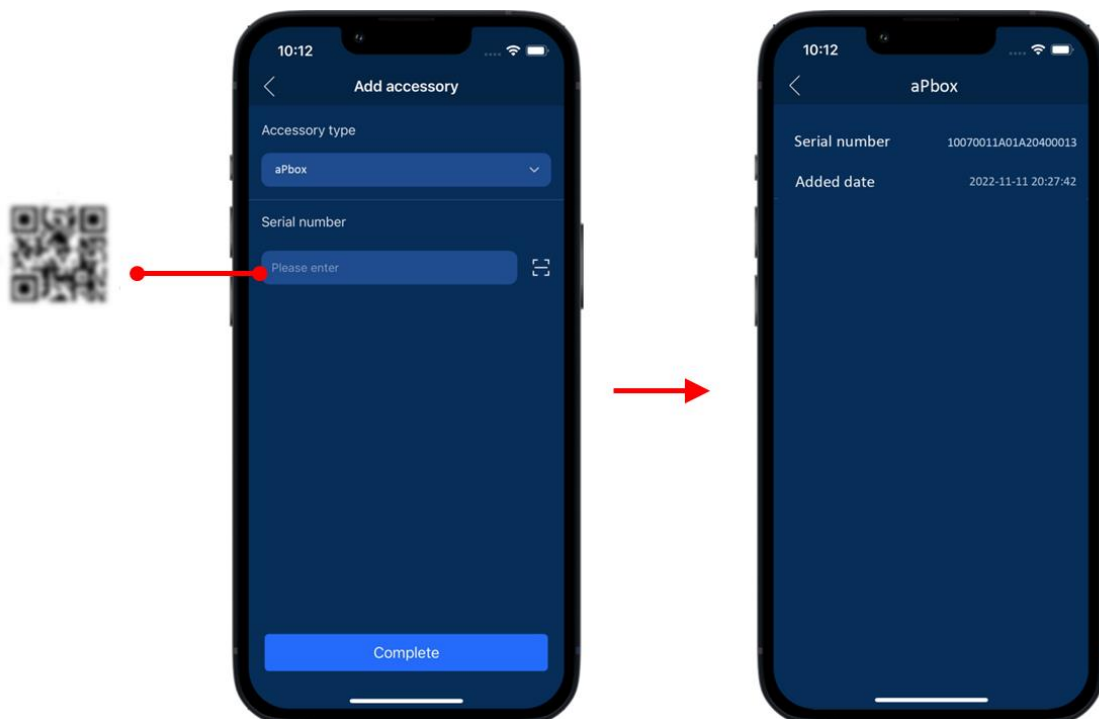

aPbox Setting

Step 1 Click “Settings” to enter the Setting screen.

Step 2 Click “Solar” to setting.

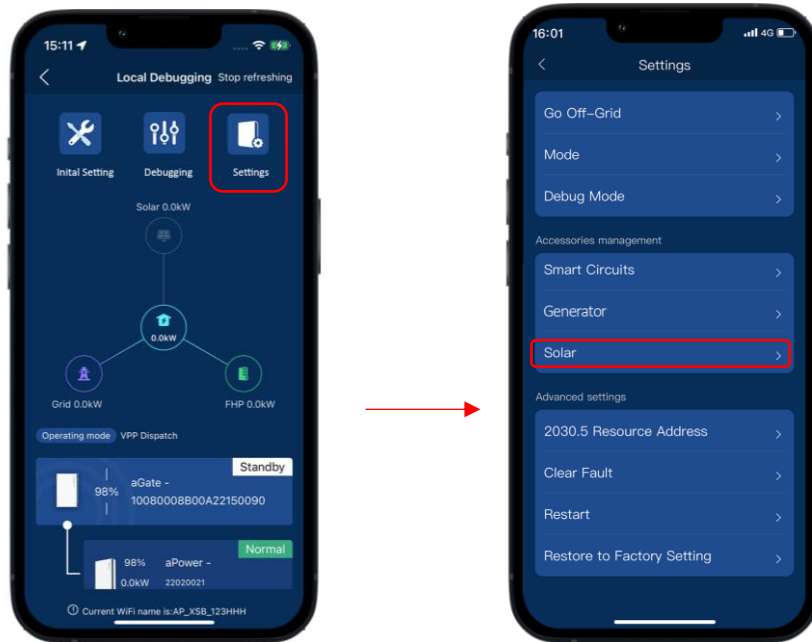

Step 3 Input the proximal solar rated power value. Enable the Remote solar access feature before setting the Remote solar, then select the appropriate access mode according to the requirements. Currently there are two kinds of access mode available, Grid-side and Load-side.

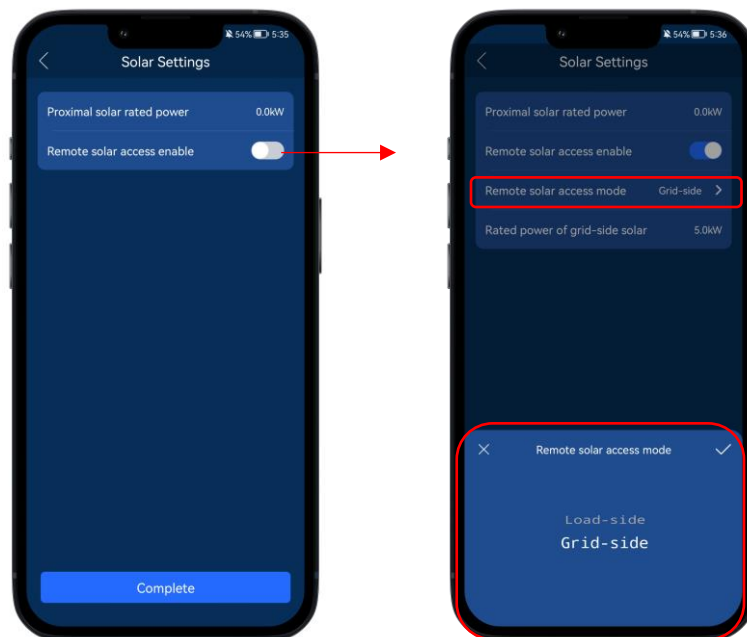

Step 4 For both grid-side and load-side, input the solar power value. For load-side, also select the number of the connected solar systems. The following images show the different screens for the Grid-side and the Load-side access modes. Then click on **Complete**.

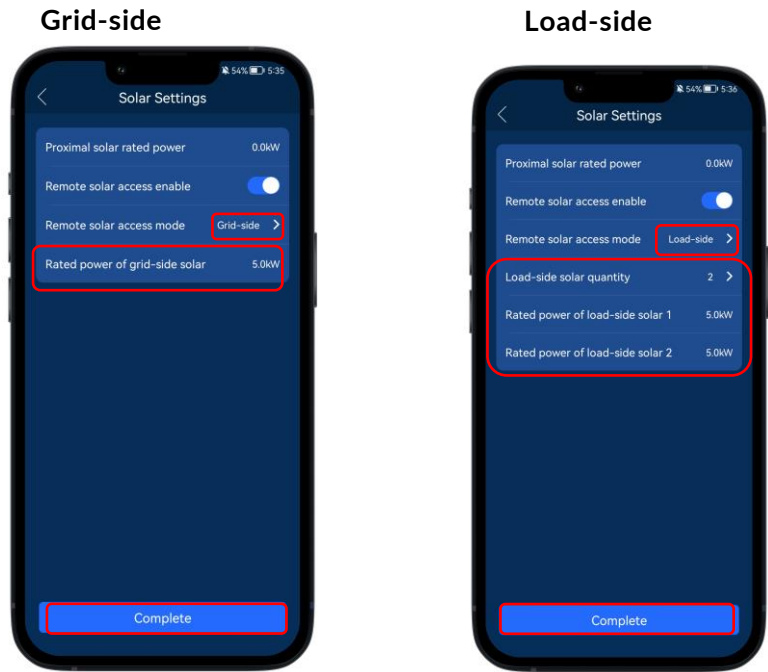

Technical Support

For further support, please contact your installer or the FranklinWH service team at www.franklinwh.com/support. Please be prepared to provide the following information before you contact FranklinWH:

- Owner name
- Your preferred desired contact method (name, phone number, email)
- The serial number of your aPbox (as shown in the figure below)
- A brief description of your problem

