

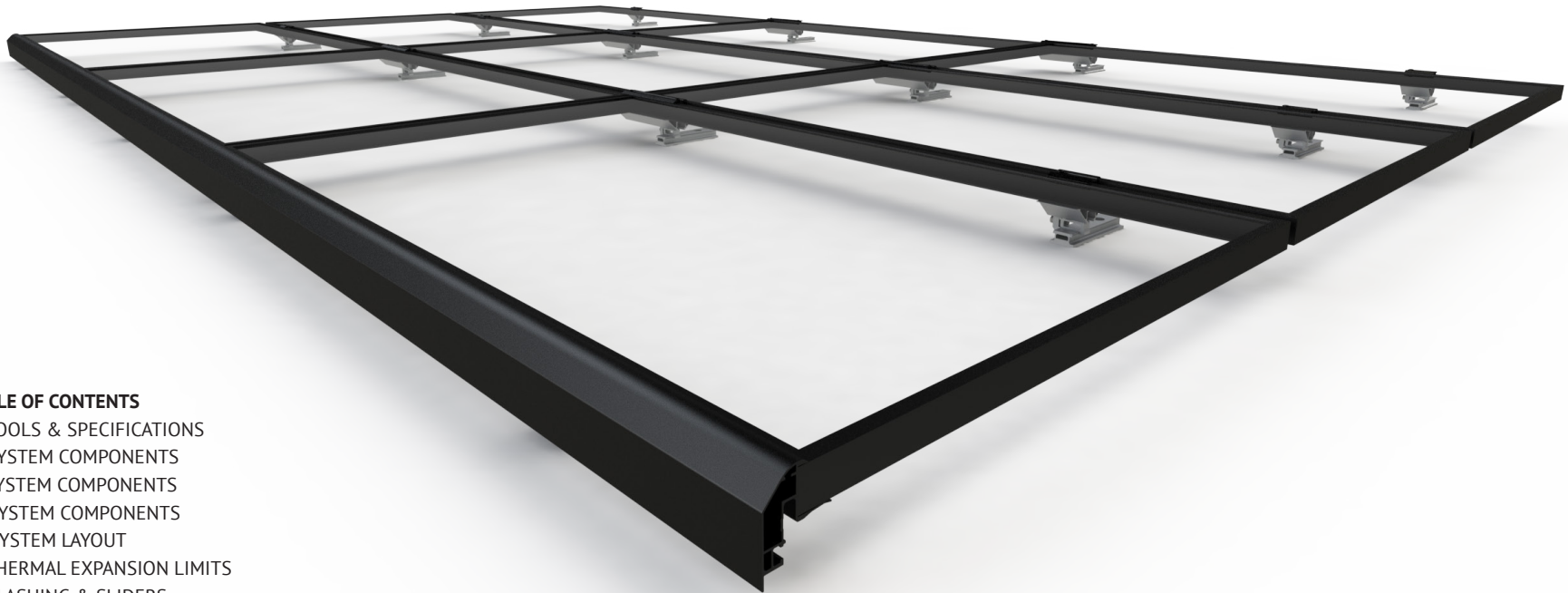

**SFM** SUN  
FRAME  
MICRORAIL™

# INSTALLATION GUIDE



## TABLE OF CONTENTS

- A- TOOLS & SPECIFICATIONS
- B- SYSTEM COMPONENTS
- C- SYSTEM COMPONENTS
- D- SYSTEM COMPONENTS
- E - SYSTEM LAYOUT
- F- THERMAL EXPANSION LIMITS
- G- FLASHING & SLIDERS
- H- 1ST ROW INSTALLATION
- I- MICRORAIL INSTALLATION
- J- MODULE MOUNTING
- K- FLOATING TRIMRAIL INSTALLATION
- L- MICROINVERTER & WIRE MGMT.
- M- MICROINVERTER & WIRE MGMT.
- N- FINISHING TOUCHES
- O- SYSTEM BONDING & GROUNDING
- P- ENPHASE SYSTEM MICROINVERTER GROUNDING
- Q- UL CODE COMPLIANCE NOTES
- R- TESTED / CERTIFIED MODULE LIST
- S- MODULE MAINTENANCE
- T- CONSIDERATIONS & MAINTENANCE

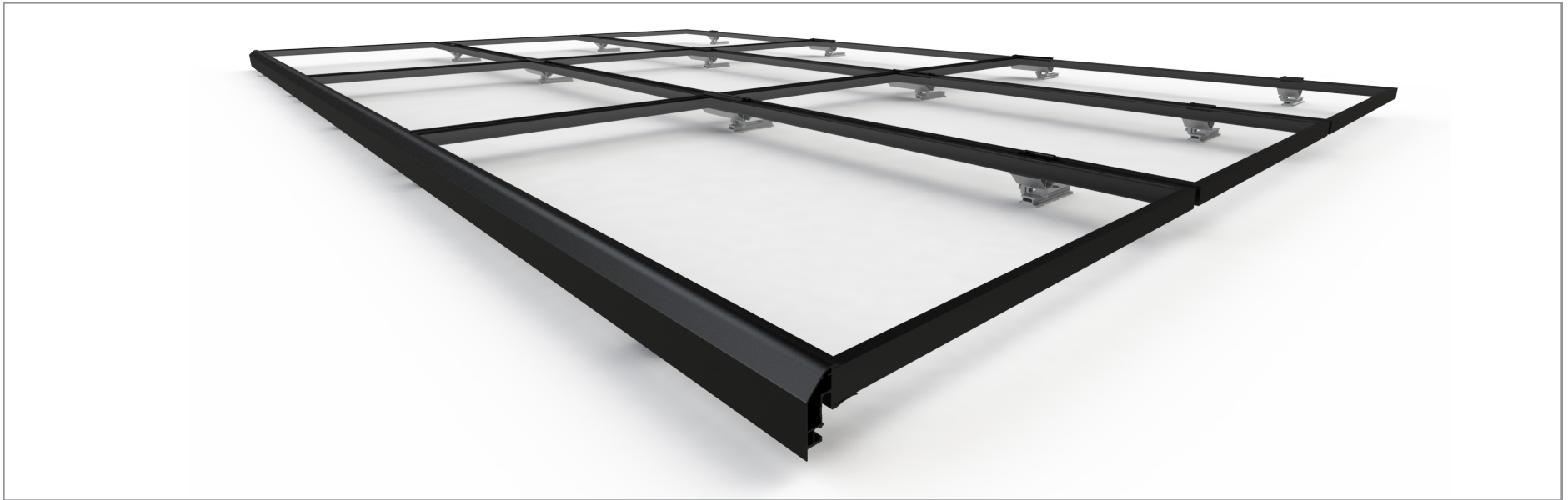

**TECHNICAL SPECIFICATIONS:**

**Material Types**

**All extruded components:**  
6005A-T61 or 6061-T6 Aluminum

**Hardware:** Stainless Steel

**Bonding and Grounding:** Integrated in Microrail™ (Trimrail™ and row to row bonding require additional components)

**TOOLS REQUIRED OR RECOMMENDED FOR LAYOUT, FLASHINGS & ROOF ATTACHMENTS:**

- Hammer
- Marker / crayon
- Measuring tape
- Drill
- Pilot drill bit
- Pry bar
- String line

**TOOLS FOR MODULE INSTALL:**

- Drill and socket adapter or socket wrench
- 1/2" socket
- 1/4" hex driver
- Torque wrench

**SAFETY:** All applicable OSHA safety guidelines should be observed when working on a PV installation job site. The installation and handling of PV solar modules, electrical installation and PV racking systems involves handling components with potentially sharp metal edges. Rules regarding the use of gloves and other personal protective equipment should be observed.

**TORQUE SPECIFICATIONS:**

All SFM Hardware	20 ft-lbs
Grounding lugs	Per Page "0"

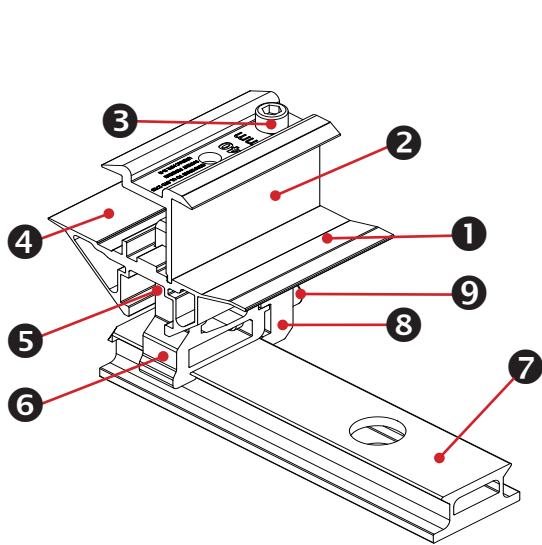

### SUNFRAME Microrail™ - 3"

#### Sub-Components:

1. 3" Base
2. 3" Cap
3. Clamp Socket Head Cap Screw
4. Bonding Pin
5. Helix
6. Tower
7. 6.75" Slider
8. Dovetail Lock
9. Dovetail Bolt

#### Functions:

- 1 or 2 module support to roof attachment

#### Features:

- Arrives on-site pre-assembled and ready for installation
- Cap indicates module height compatibility
  - Supports discrete module thicknesses from 32mm to 46mm
- Receiving feature that allows simple module placement, tightening of fasteners and eliminates working over modules.

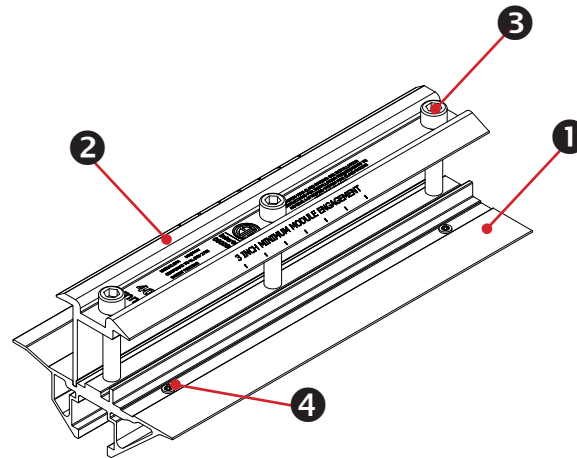

### SUNFRAME Microrail™ 9" Splice

#### Sub-Components:

1. 9" Base
2. 9" Cap
3. (3) Clamping Socket Head Cap Screws
4. Bonding Pins

#### Functions:

- 2,3 or 4 module support & connection
- E-W module to module bonding

#### Features:

- Arrives on-site pre-assembled and ready for installation
- Cap indicates module height compatibility
  - Supports discrete module thickness from 32mm to 46mm
- Receiving feature that allows simple module placement, tightening of fasteners and eliminates working over modules.
- Does not require attachment to roof

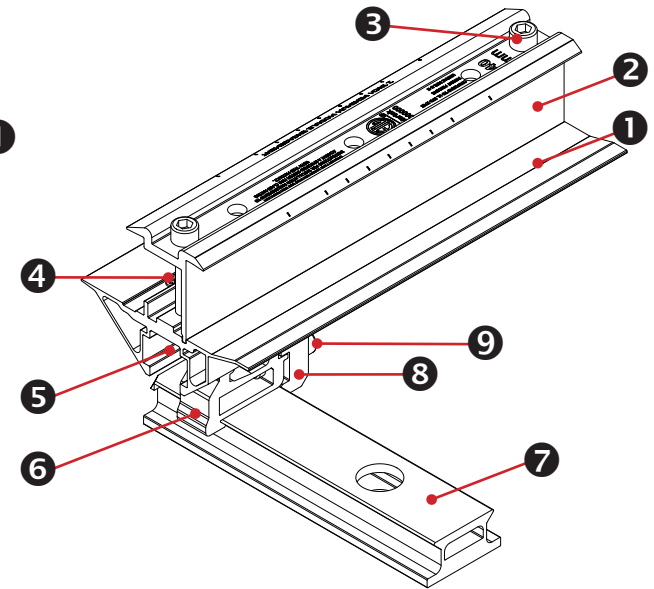

### SUNFRAME Microrail™ 9" Attached Splice

#### Sub-Components:

1. 9" Base
2. 9" Cap
3. (2) Clamp Socket Head Cap Screws
4. Bonding Pins
5. Helix
6. Tower
7. 6.75" Slider
8. Dovetail Lock
9. Dovetail Bolt

#### Functions:

- Module to roof attachment (when attachment is necessary at splice point)
- E-W module to module bonding

#### Features:

- Arrives on-site pre-assembled and ready for installation
- Cap indicates module height compatibility
  - Supports discrete module thickness from 32mm to 46mm
- Receiving feature that allows simple module placement, tightening of fasteners and eliminates working over modules.

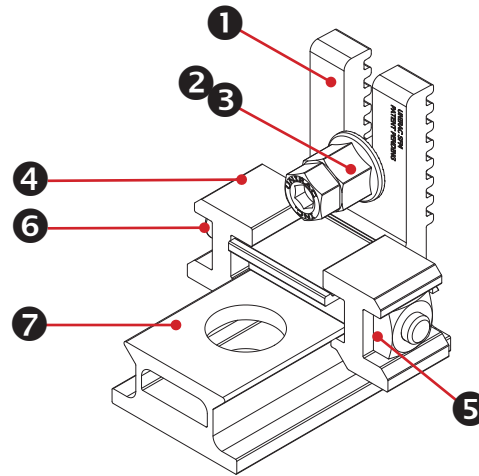
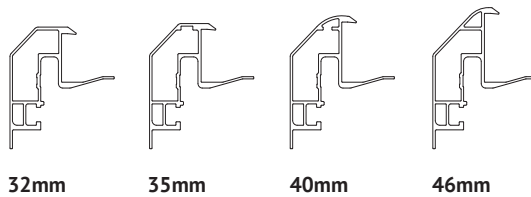
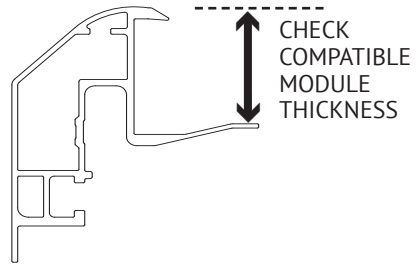

FLOATING TRIM CLIP

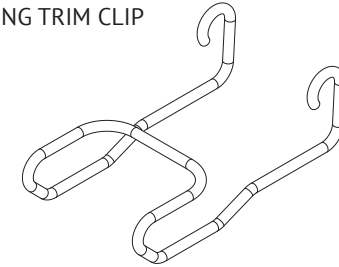

SPLICE

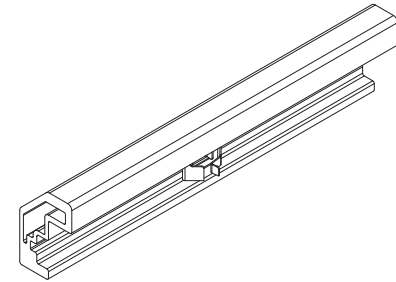

## Trimrail™

### Functions:

- Required front row structural support
- Module mounting
- Installation aid
- Aesthetic trim

### Features:

- Mounts directly to L-feet
- Aligns and captures module leading edge
- Available for various module heights
  - Supports discrete module thicknesses from 32mm to 46mm

## Trimrail™ Roof Attachment

### Sub-Components:

1. Trimrail roof attachment
2. Hex bolt and Tri-drive nut
3. Tri-drive nut
4. Dovetail locks
5. Square nut
6. Clamp bolt
7. 3" Slider

### Functions:

- Attach Trimrail™ to roof attachment / flashing

### Features:

- Slots provide vertical adjustments to level array
- Slider provides north/south adjustment along the slope of the roof.

## Floating Trim Clip

### Functions:

- Attaches Trimrail™ to module when fewer than 2 rafter attachment points are available

### Features:

- Compatible with all Trimrail™ profiles
- Tool-less installation

## Trimrail™ Splice

### Functions:

- Front row structural support
- Installation aid
- Structurally connects 2 pieces of Trimrail™

### Features:

- Aligns and connects Trimrail™ pieces
- Compatible with all Trimrail™ profiles
- Tool-less installation

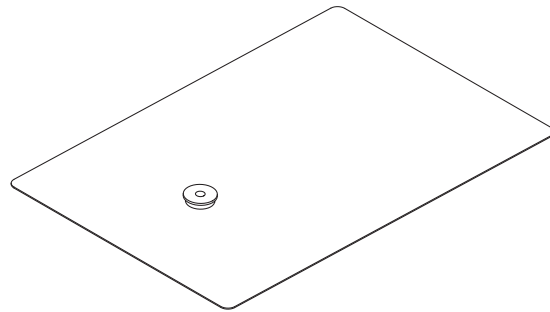

### SFM Flat Flashing

**Functions:**

- Patented roof sealing technology at roof attachment point
- For use with compatible 3" & 6.75" SFM Sliders  
(See Unirac Master Price List for details)

**Features:**

- Integrated EDPM Rubber Bushing
- Manufactured by EcoFasten Solar



Wire Bonding Clip w/ 8AWG

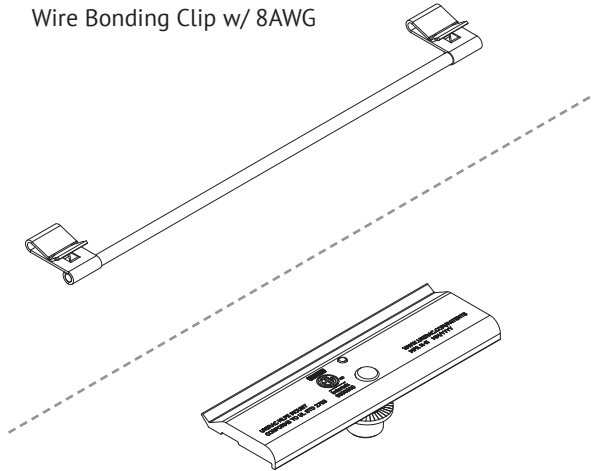

MLPE Mounting Assembly

### Wire Bonding Clip w/ 8AWG

**Functions:**

- Row to row bonding
- Module to Trimrail™ bonding
- Single Use Only

**Features:**

- No fasteners required

### MLPE Mounting Assembly

**Functions:**

- Securely mounts MLPE to module frames
- MLPE to module bonding

**Features:**

- Mounts easily to typical module flange
- UL2703 Recognized

MLPE = Module Level Power Electronics,  
e.g. microinverter or power optimizer

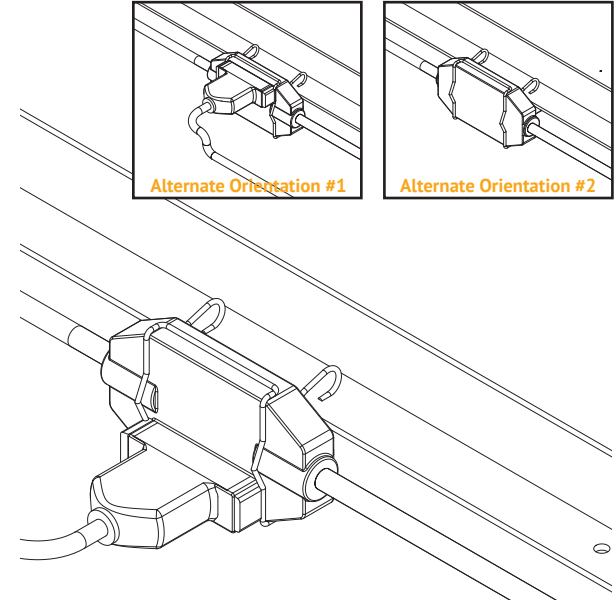
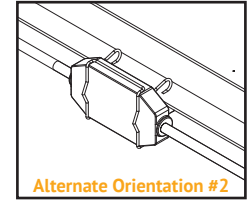
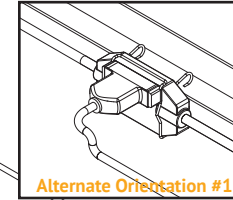

### Enphase Engage Cable Clip

**Functions:**

- Securely attaches Enphase Engage cables to module flanges
- Allows three (3) mounting positions to suit any cable orientation

**Features:**

- Resists sliding to reduce cable slack

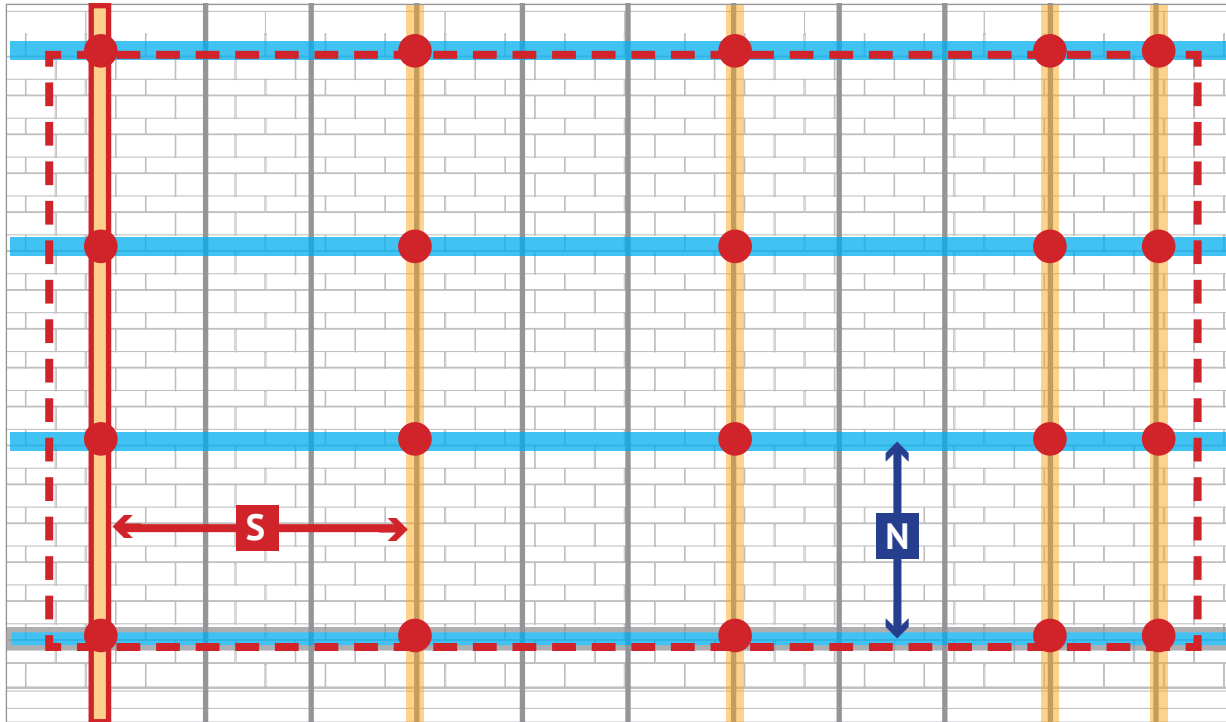

1. Determine appropriate array location on roof. **NOTE: Consult local AHJ regarding setback requirements**
2. Select starting course of shingles (or tiles)
3. Mark next row of attachments and repeat for remaining rows
- N** - NS distance equals module width +1"
4. Locate 1st rafter closest to array edge (and inside array footprint) and mark
5. Find next rafter for attachment based on appropriate span
  - Continue to end of array
  - Mark last rafter before end of array
- S** Span
6. Mark attachment points on rafters along each NS module grid line
7. Refer to Unirac SFM D&E Guide and U-Builder for allowable spans and cantilevers.

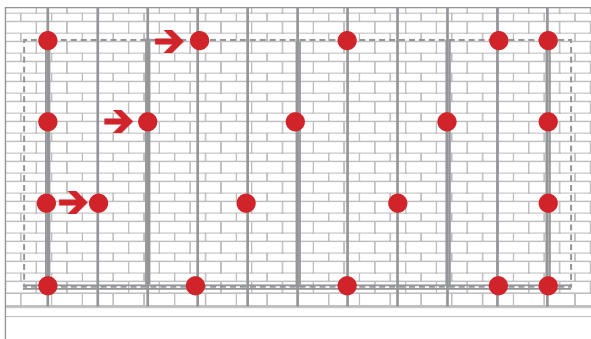

**TO STAGGER ATTACHMENTS:** Shift each subsequent row of attachments one rafter over.

See the Design and Engineering Guide for details on regional max spans and overhang.

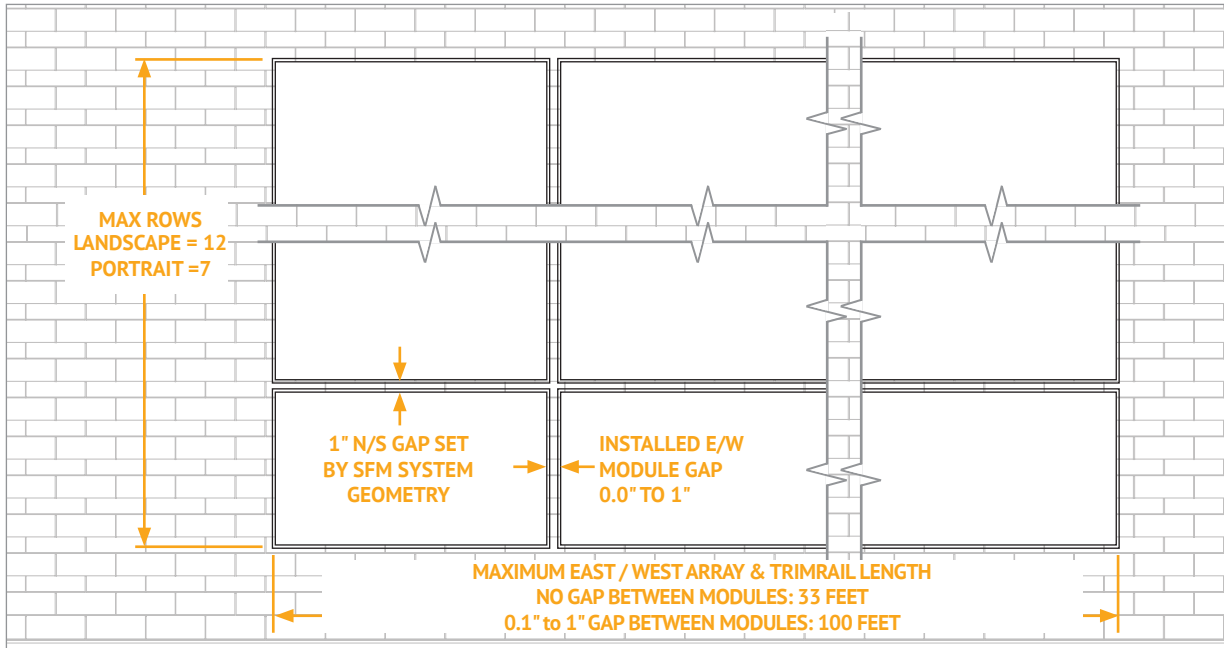

**NORTH-SOUTH THERMAL EXPANSION LIMITS:**

- 12 Rows of modules - Landscape orientation
- 7 Rows of modules - Portrait Orientation

**EAST-WEST THERMAL EXPANSION LIMITS:**

- 33ft. with no module gap (butted modules)
- 100ft. with a minimum module gap of 1/8"

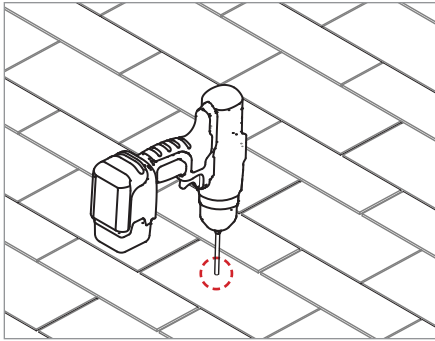

**PILOT HOLES:** Drill pilot holes for lag screws or structural screws (as necessary)

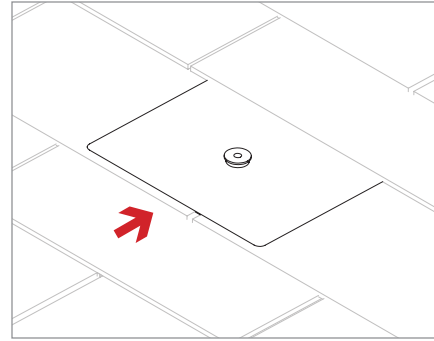

**FLASHINGS:** Place flashings

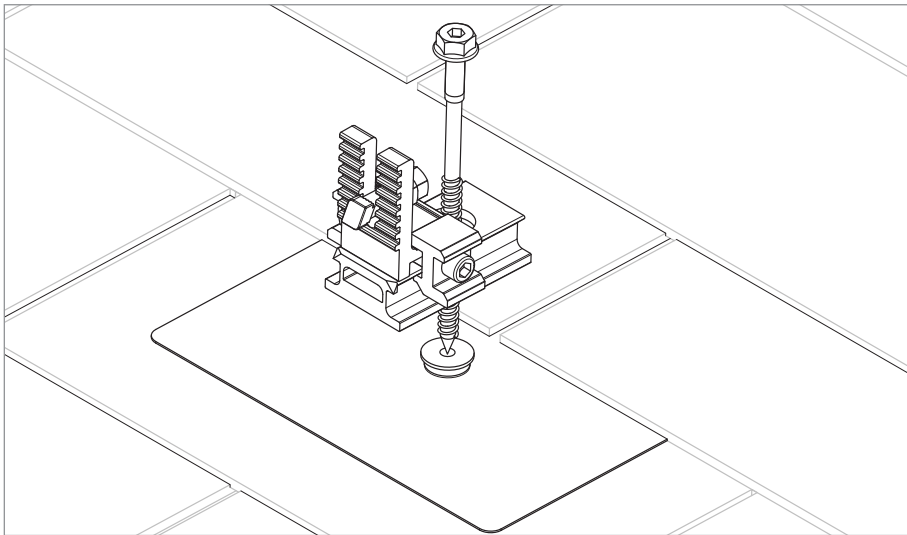

**INSTALL SLIDERS AND TRIMRAIL ROOF ATTACHMENTS:**

- Insert flashings per manufacturer instructions
- Attach sliders to rafters
- Verify proper row to row spacing for module size (Mod NS + 1")
- Ensure that Trimrail™ roof attachments in each row have sufficient engagement with slider dovetails for proper attachment.

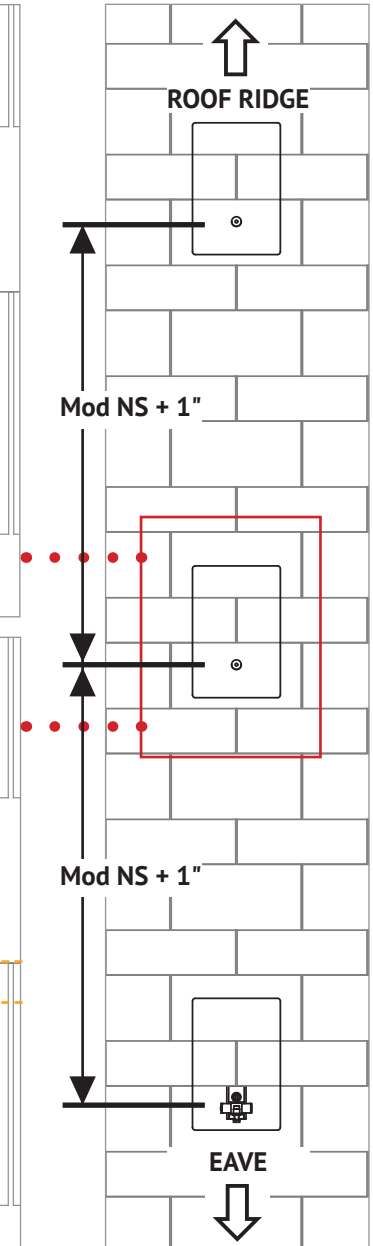
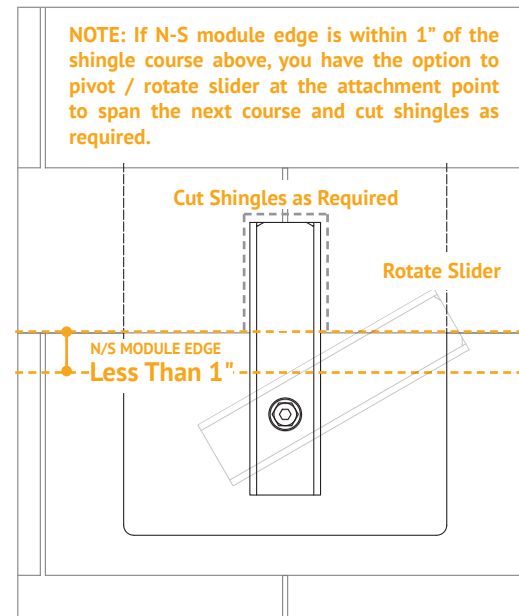
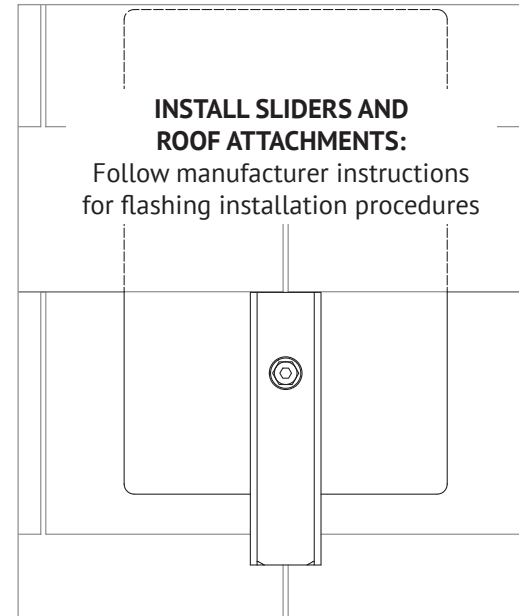



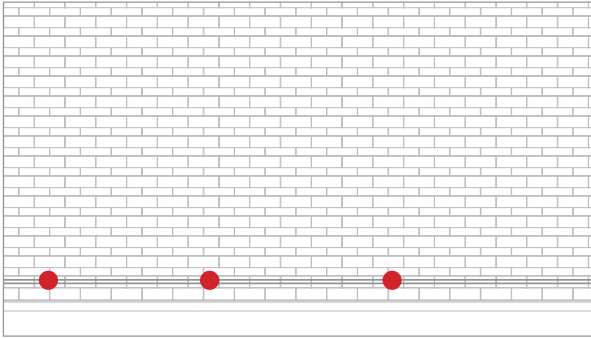

**ALIGN FRONT ROW:**

Align front row Trimrail™ roof attachments with string line

**TIP:** Pull String-line across back (smooth) edge of attachments

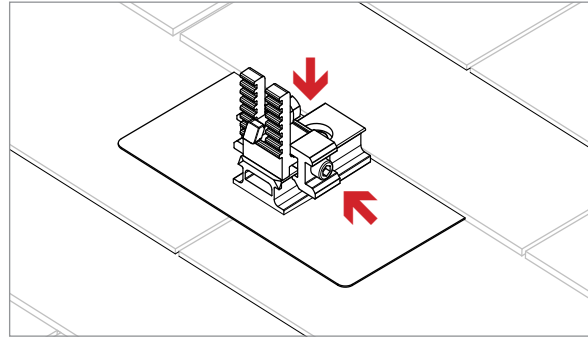

**TIGHTEN SLIDER:**

Tighten front row lag screw and Trimrail™ roof attachments dovetail clamp bolt.

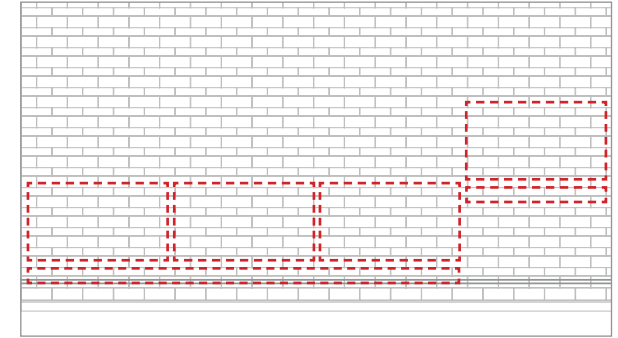

**TRIMRAIL PREPARATION:**

Determine overall length of Trimrail™ for front row. Determine splice locations (if any) and Trimrail™ lengths required. When 2 or less attachment points are available at front of module edge, a Trimrail floating clip may be required, see page (K) for details.

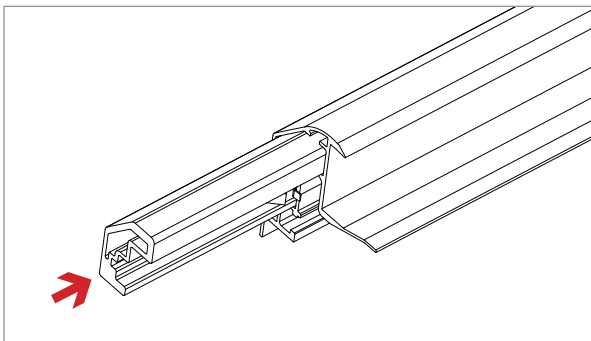

**INSTALL TRIMRAIL SPLICE BARS:** Place Trimrail™ with front side up and firmly insert splice bar into Trimrail™, until it clicks.

**NOTE:** Do not over-insert splice

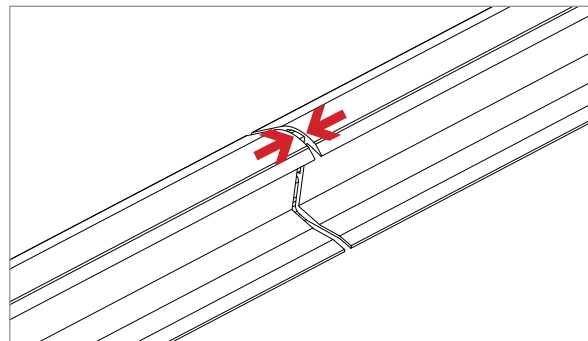

**ATTACH SPLICE BARS:** While holding Trimrail™ sections in alignment, join sections together with splice bar centered at joint. Bonding between trim sections occurs through the splice bar.

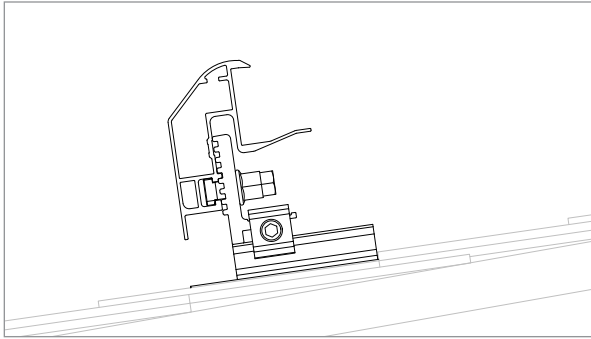

**TRIMRAIL ROOF ATTACHMENTS & TRIMRAIL ORIENTATION:** Trimrail™ roof attachment should have horizontal flange facing uphill for uniform row spacing and ease of lag screw assembly. On first row, position Trimrail™ with module catch side facing uphill.

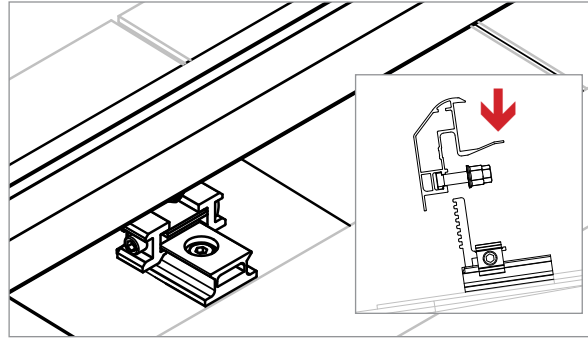

**ATTACH TRIMRAIL TO ROOF ATTACHMENT:** Attach rail using 3/8" hex bolt & Tri-drive nut and serrated flange nuts. Make sure Trimrail™ is level across all Trimrail™ roof attachments. After rail is level, tighten dovetail bolts to secure Trimrail™ roof attachments to sliders.

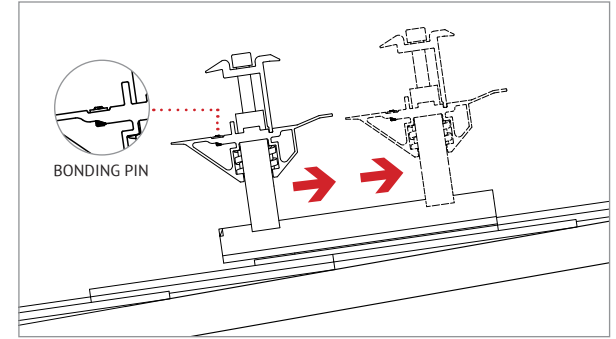

**INSTALL MICRORAILS:** Install remaining Microrails at marked attachment points. Loosen dovetail retaining fastener and push Microrail™ to top of slider. **DO NOT SLIDE ALL THE WAY OFF SLIDER.**

**NOTE:** Bonding pin on Microrails should be positioned downslope.

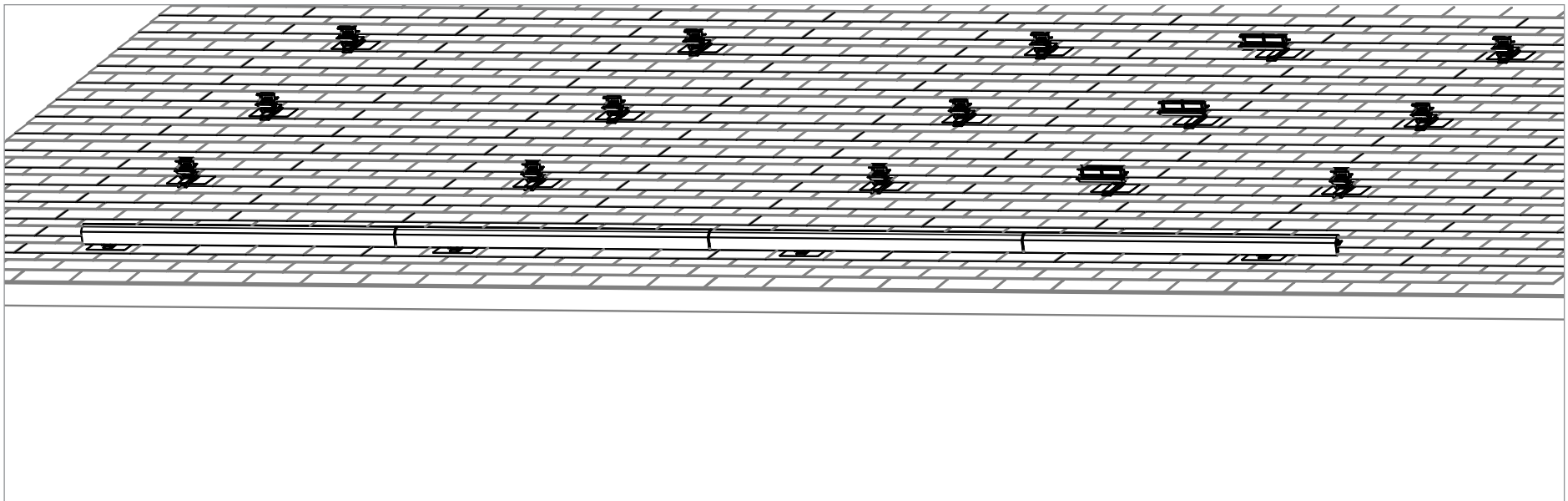

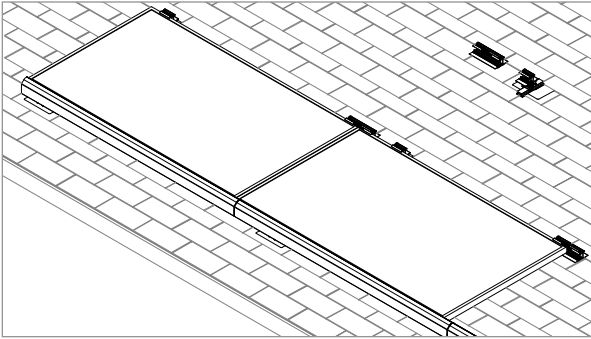

**LAY IN MODULE(S):** Install first two (2) modules on bottom row. Install downhill end of module into the Trimrail™ first and then position uphill 3" microrails to support modules.

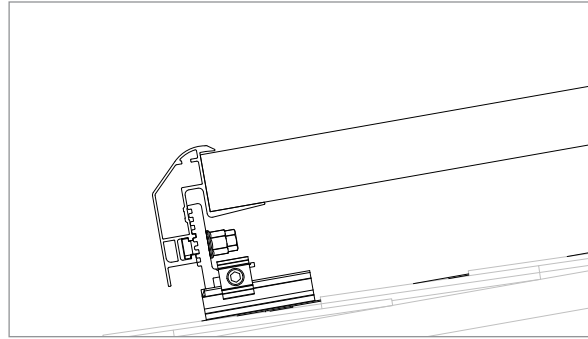

**LAY IN MODULE(S):** Module should slide into catch feature of the Trimrail™.

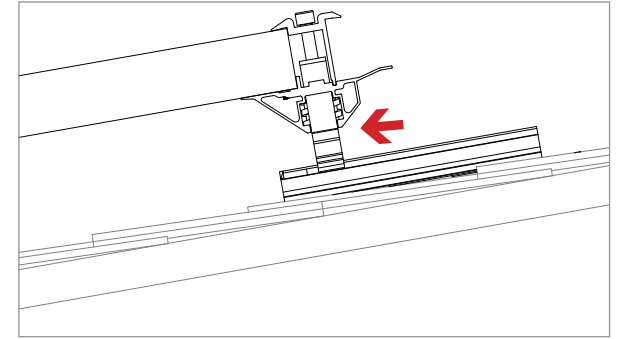

**SEAT MODULE(S):** Ensure that modules are properly seated in top cap and base.

Wire management is performed after each row of modules is installed. Refer to wire management section (pp. L & M) for detailed instructions.

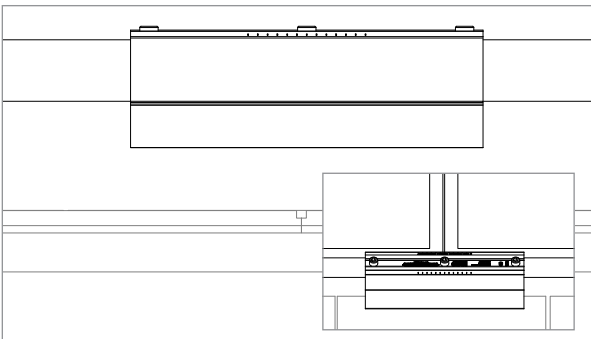

**ATTACH SPLICE:** Attach splice at intersection of two (2) modules.

- Use attached splice if necessary.
- Ensure minimum module engagement using indicator marks.

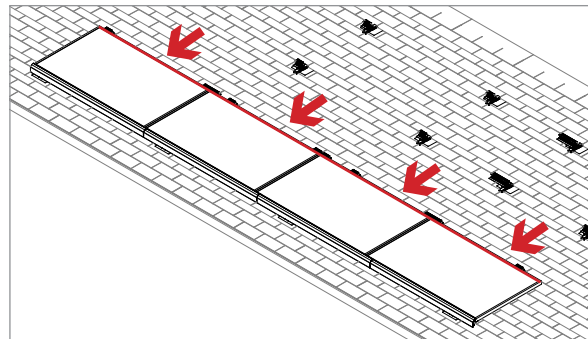

**FASTEN MODULES:** Finish installing modules along row and tighten fastening bolts after entire row is installed.

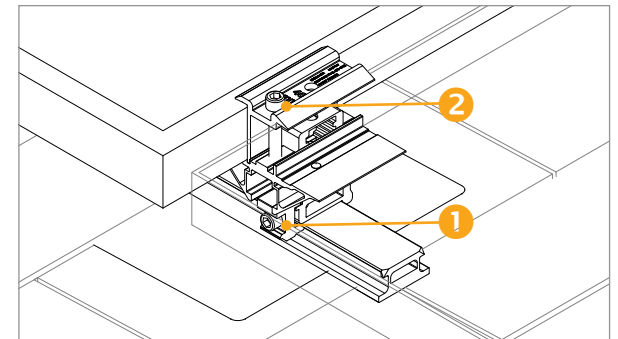

**TIGHTEN FASTENERS:** Tighten fasteners to required torque.

**NOTE:** Tighten components from the roof up, ① Dovetail Bolt then ② Clamp Socket Head Cap Screw

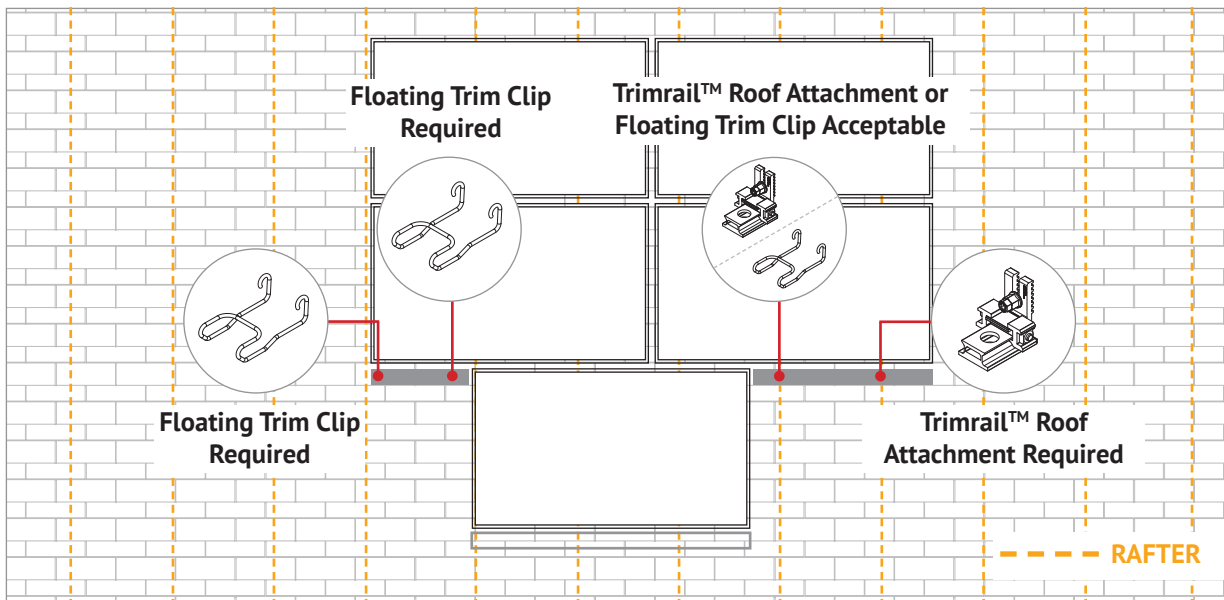
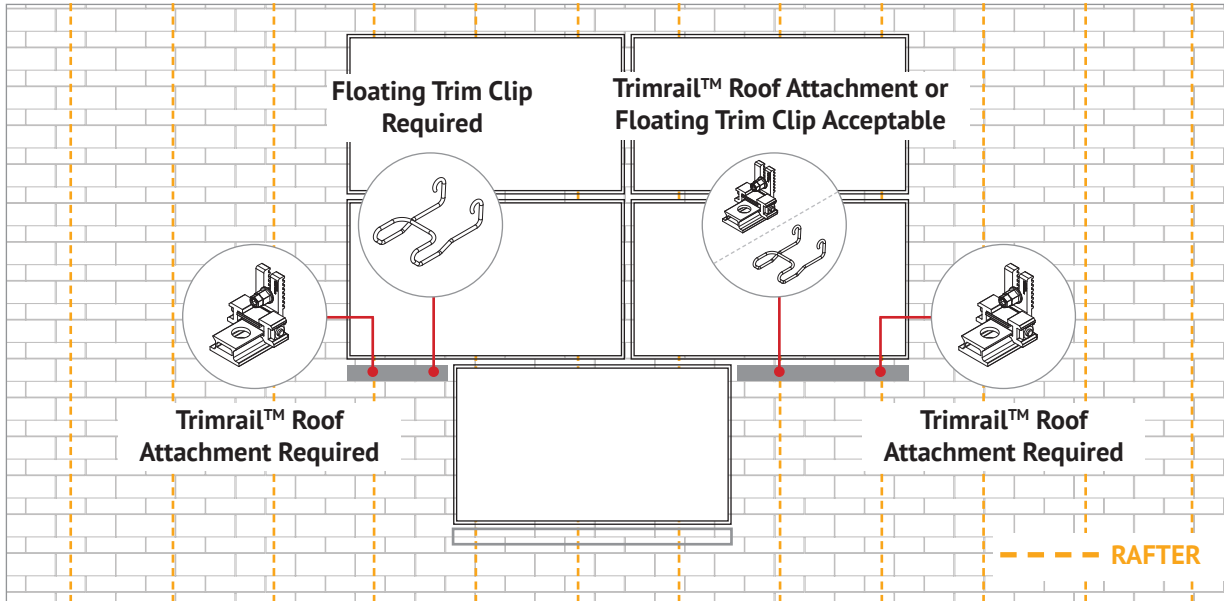

### REQUIREMENTS FOR TRIMRAIL ROOF ATTACHMENTS & FLOATING TRIM CLIP:

Trimrail™ Roof Attachments shall be used at rafters nearest to outside edge of array.

- Use Floating Trim Clip on the longest "free" side if only one (1) Trimrail™ Roof Attachment is utilized.
- Use of 2 Floating Trim Clip(s) without a Trimrail™ Roof Attachment is acceptable if the section of Trimrail™ being mounting is less than 24" and there are no available roof attachment points.

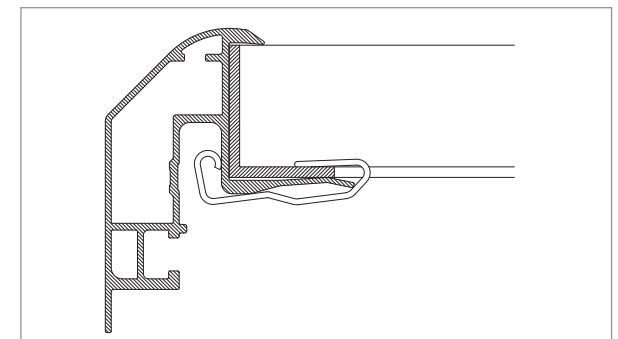

### SECURING TRIMRAIL WITH FLOATING TRIM CLIPS:

When necessary, use floating trim clips to secure trimrail to module. Installation should occur after module is secured. Floating Trim Clip captures module flange and clips inside of trimrail as shown above.

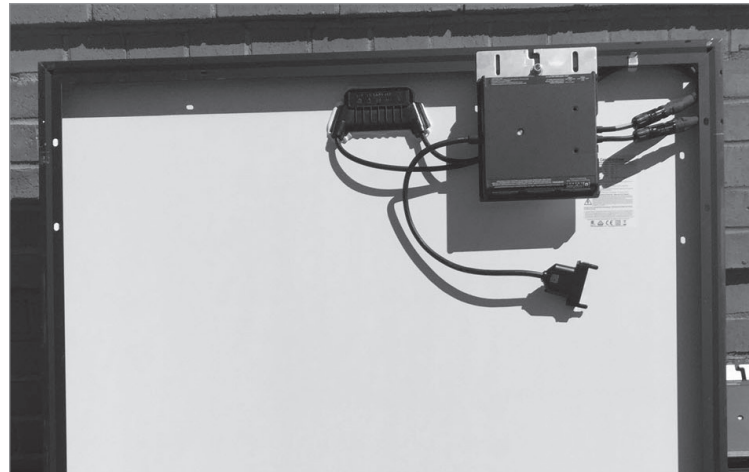
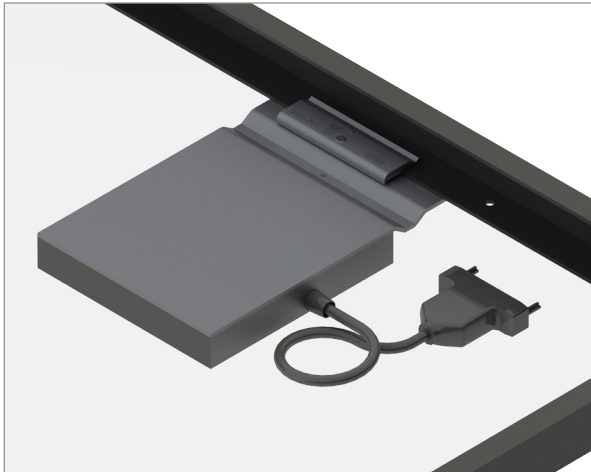

**PRE-INSTALL MLPE:** Install MLPE in a location on the module that will not interfere with microrails or grounding lugs. To use trunk cable most efficiently, install MLPE components in the same locations on all modules in the same row.

**TORQUE VALUE: 20FT-LBS (SEE NOTE ON PAGE A)**

**MLPE MOUNTING LOCATION & WIRE MANAGEMENT:** Install the MLPE Mount on the short side of the module when mounting in landscape orientation. Install MLPE Mount on the long side of module when mounting in portrait orientation.

**ABOVE IMAGE: MLPE mount w/ microinverter & wire management**

**BELOW IMAGE: MLPE mount w/ power optimizer & wire mgmt.**

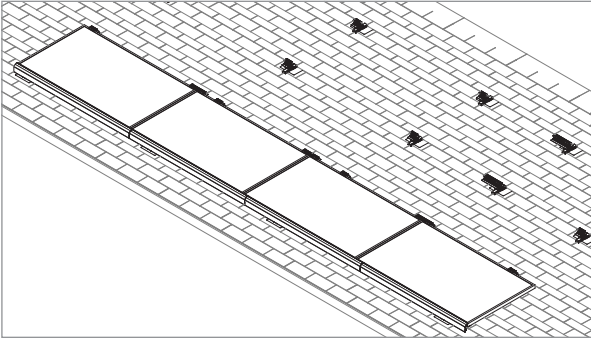

**MICROINVERTER:** Before installing a row of modules place microinverter trunk cable.

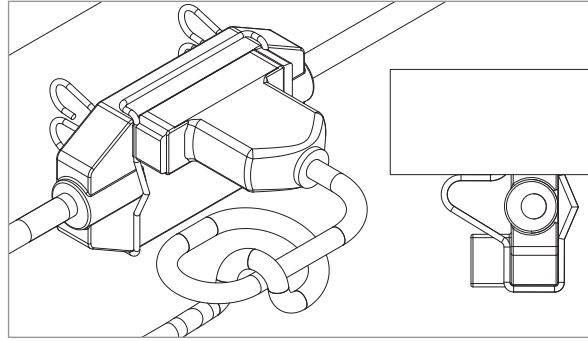

**MICROINVERTER CONNECTION:** Before securing a module to the Microrails, install trunk cable mounting clip on the connector block. Attach clip to module flange. Plug microinverter into connector.

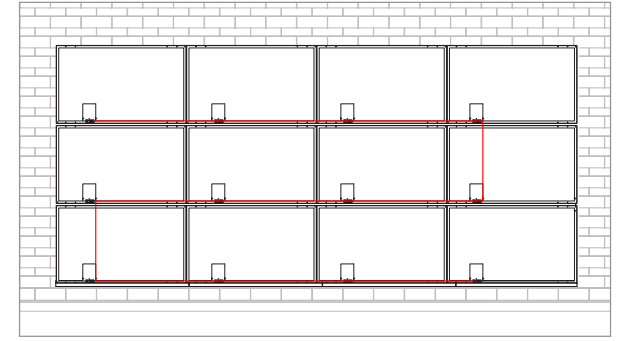

**WIRE MANAGEMENT:** Verify wire management is complete after each row is installed.

## EXAMPLES:

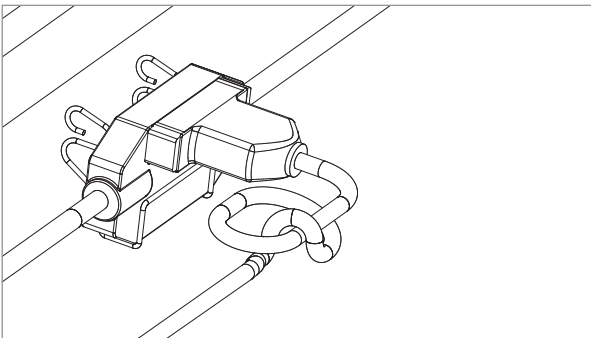

**TIPS & TRICKS:** Tie a loose knot in the microinverter Engage connector wire to help manage the length.

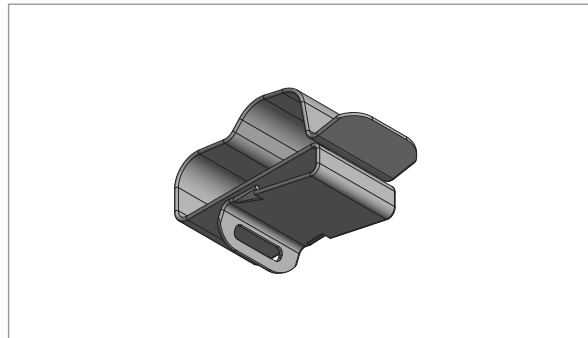

**MICROINVERTER TRUNK CABLE:** The trunk cable can be managed securely by using stainless steel wire management clips attached to the module frame.

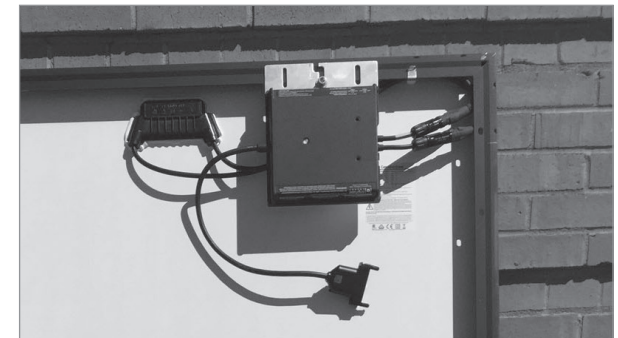

**TIPS & TRICKS:** Twisting the PV module wires and / or tying a loose knot can also help manage these wires.

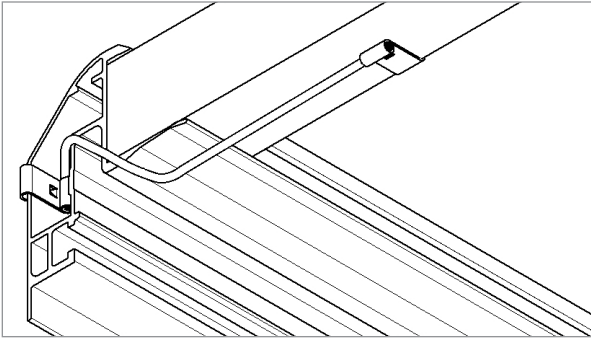

**TRIMRAIL BONDING:** Attach a bonding clip from the Trimrail™ to an adjacent module. Fully seat bonding clip until radius portion is in contact with Trimrail™ mating surface and module flange.

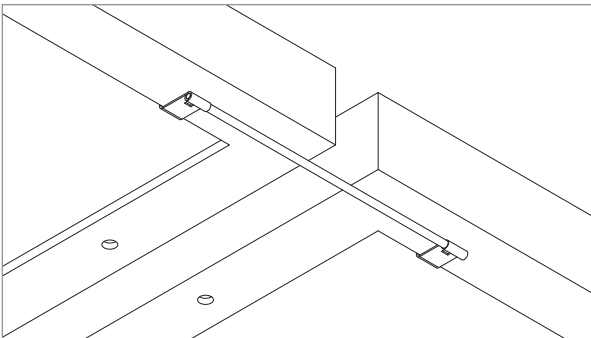

**N/S Bonding Clip:** A N/S bonding clip must be used to bond adjacent rows of modules together.

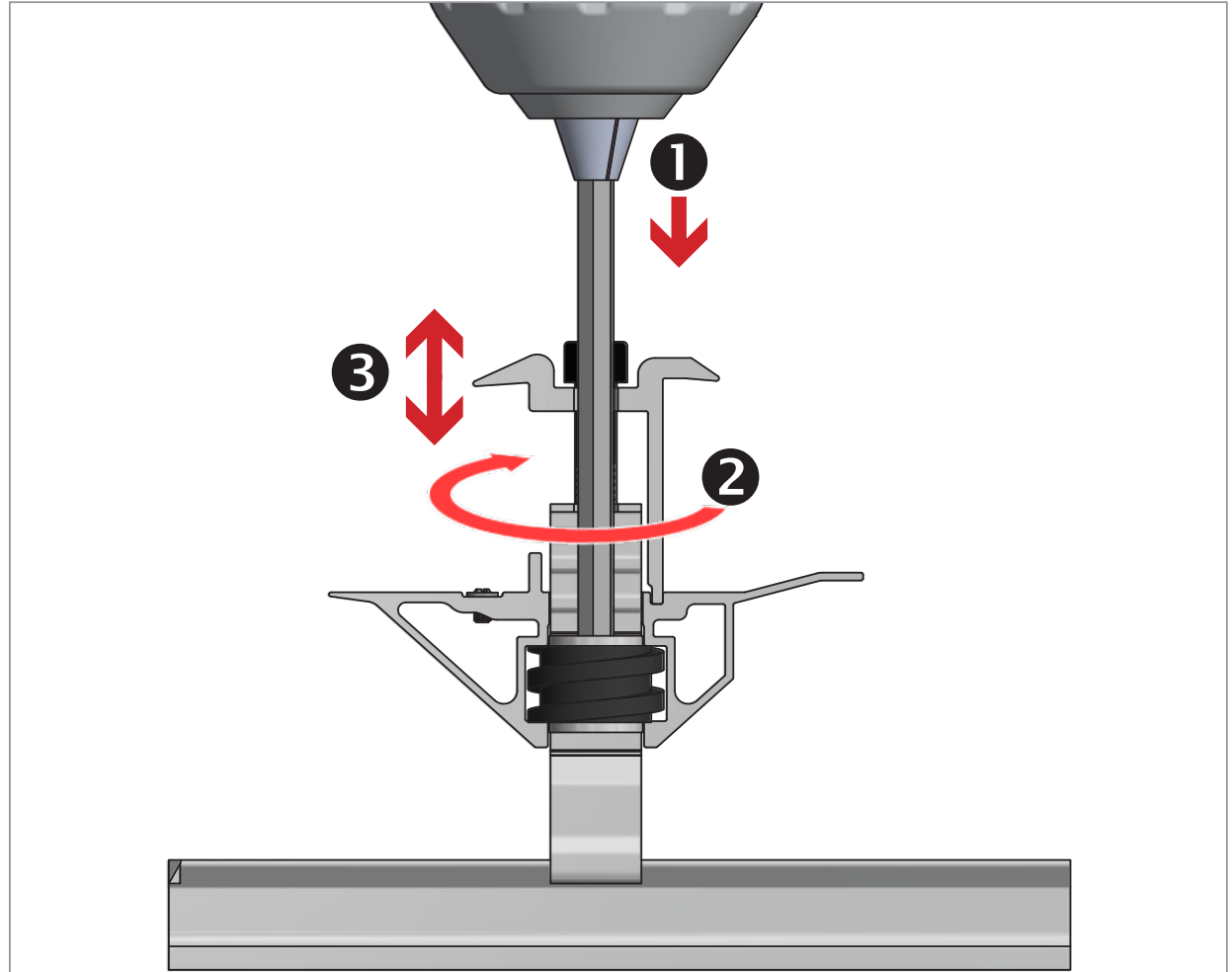

**POST INSTALL HEIGHT ADJUSTMENT:** Height adjustment of each attached Microrail™ assembly can be performed by inserting a long 1/4" hex drive through the cap and into the helix. **CAUTION: DO NOT RAISE THE BASE HIGHER THAN THE TOP OF THE TOWER.**

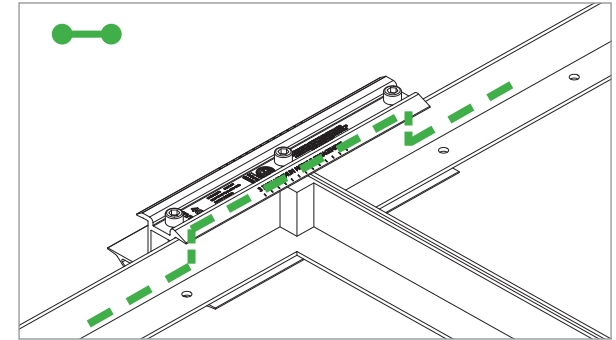
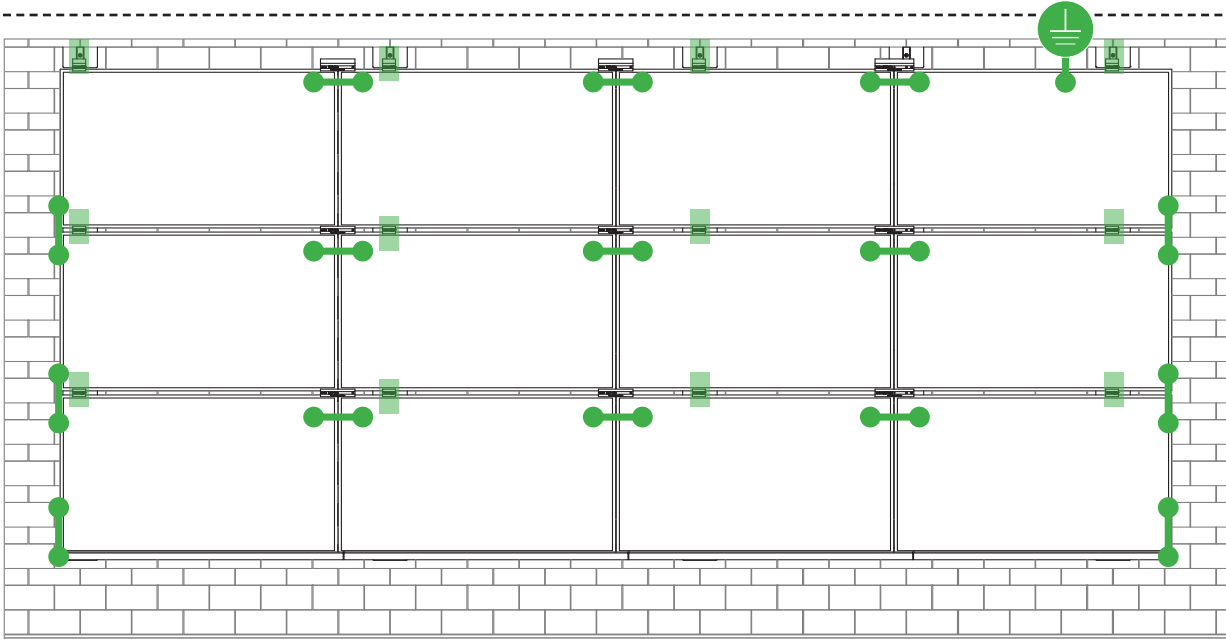

**E-W BONDING PATH:** E-W module to module bonding is accomplished with 2 pre-installed bonding clips which engage on the secure side of the Microrail™ and splice.

Star Washer is Single Use Only

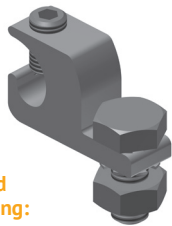

**TERMINAL TORQUE,**  
Install Conductor and torque to the following:  
4-6 AWG: 35in-lbs  
8 AWG: 25 in-lbs  
10-14 AWG: 20 in-lbs

**LUG DETAIL & TORQUE INFO**  
**IlSCO Lay-In Lug (GBL-4DBT)**

- 10-32 mounting hardware
- Torque = 5 ft-lb
- AWG 4-14 - Solid or Stranded

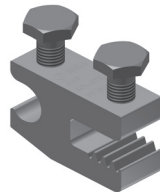

**TERMINAL TORQUE,**  
Install Conductor and torque to the following:  
4-14 AWG: 35in-lbs

**LUG DETAIL & TORQUE INFO**  
**IlSCO Flange Lug (SGB-4)**

- 1/4" mounting hardware
- Torque = 75 in-lb
- AWG 4-14 - Solid or Stranded

WEEBLUG Single Use Only

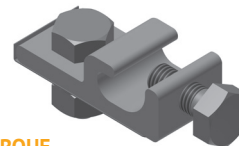

**TERMINAL TORQUE,**  
Install Conductor and torque to the following:  
6-14 AWG: 7ft-lbs

**LUG DETAIL & TORQUE INFO**  
**Wiley WEEBLug (6.7)**

- 1/4" mounting hardware
- Torque = 10 ft-lb
- AWG 6-14 - Solid or Stranded

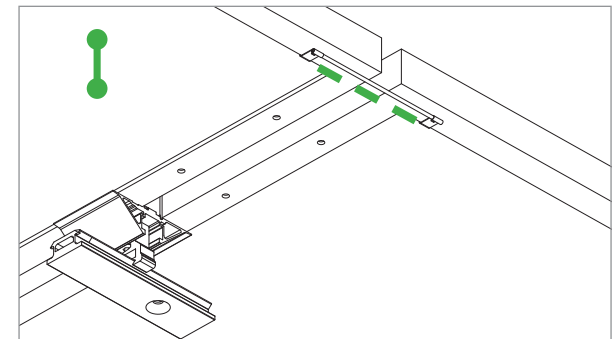

**N-S BONDING PATH:** N-S system bonding is accomplished through a N-S bonding clip. Insert each end of the N-S bonding clip onto a module frame flange. **It is recommended that N-S bonding clips be installed on both edges of the array.**

**NOTE: ISOLATE COPPER FROM ALUMINUM CONTACT TO PREVENT CORROSION**

**System bonding is accomplished through modules. System grounding accomplished by attaching a ground lug to any module at a location on the module specified by the module manufacturer.**



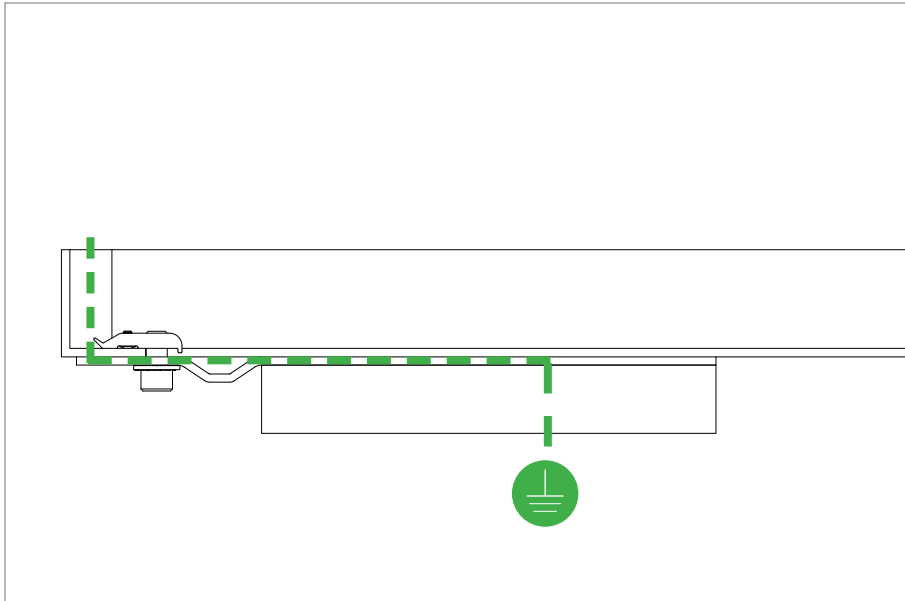

#### **SFM EQUIPMENT GROUNDING THROUGH ENPHASE MICROINVERTERS**

The Enphase M215 and M250 microinverters have integrated grounding capabilities built in. In this case, the DC circuit is isolated from the AC circuit, and the AC equipment grounding conductor (EGC) is built into the Enphase Engage integrated grounding (IG) cabling.

In order to ground the SunFrame Microrail racking system through the Enphase Microinverter and Engage cable assembly, there must be a minimum of three PV modules connected to the same trunk cable within a continuous array. Continuous array is defined as a grouping of modules installed and electrically bonded per the requirements of this installation guide. The microinverters are bonded to the SunFrame Microrail via the mounting hardware. Complete equipment grounding is achieved through the Enphase Engage cabling with integrated grounding (IG). No additional EGC grounding cables are required, as all fault current is carried to ground through the Engage cable.

### SYSTEM LEVEL FIRE CLASSIFICATION

The system fire class rating requires installation in the manner specified in the SUNFRAME MICRORAIL (SFM) Installation Guide. SFM has been classified to the system level fire portion of UL 1703. This UL 1703 classification has been incorporated into the UL 2703 product certification. SFM has achieved Class A, B & C system level performance for low slope & steep sloped roofs when used in conjunction with type 1 and type 2 modules. Class A, B & C system level fire performance is inherent in the SFM design, and no additional mitigation measures are required. The fire classification rating is valid for any roof pitch. There is no required minimum or maximum height limitation above the roof deck to maintain the Class A, B & C fire rating for SFM. SUNFRAME MICRORAIL™ components shall be mounted over a fire resistant roof covering rated for the application.

Module Type	Roof Slope	System Level Fire Rating	Microrail Direction	Module Orientation	Mitigation Required
Type 1 and Type 2	Steep Slope & Low Slope	Class A, B & C	East-West	Landscape OR Portrait	None Required

### UL2703 TEST MODULES









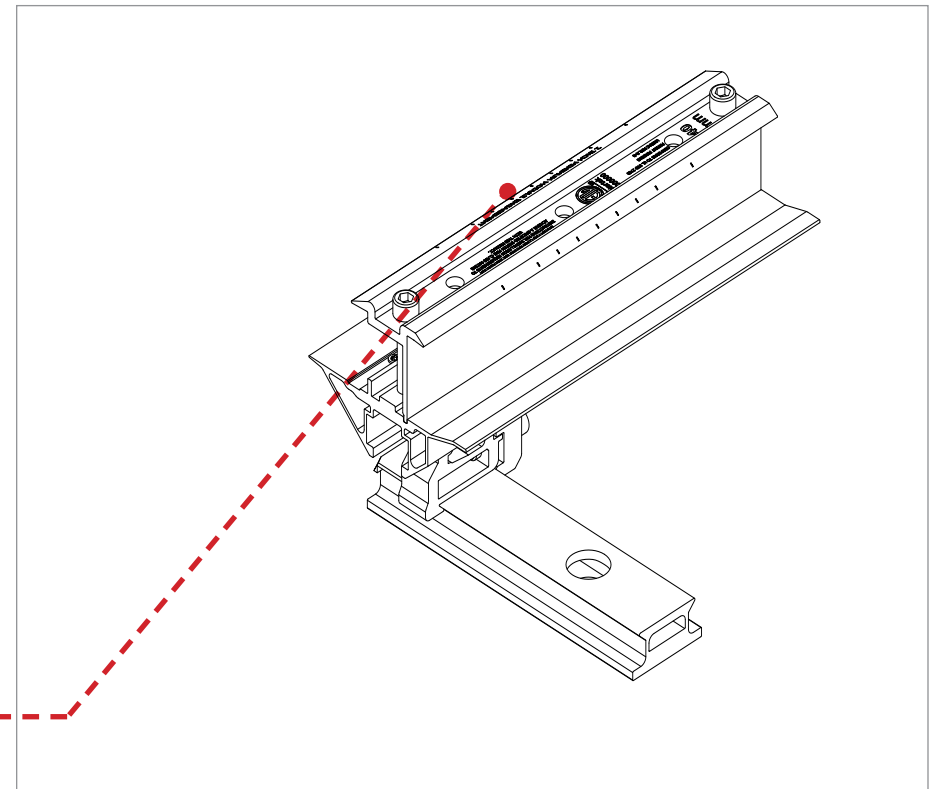





See page "R" for a list of modules that were electrically and mechanically tested or qualified with the SUNFRAME MICRORAIL (SFM) components outlined within this Installation Guide.

- Maximum Area of Module = 17.98sqft
- UL2703 Design Load Ratings:
  - a) Downward Pressure – 33 PSF
  - b) Upward Pressure – 33 PSF
  - c) Down-Slope Load – 10 PSF
- Tested Loads:
  - a) Downward Pressure – 50 PSF / 2400 Pa
  - b) Upward Pressure – 50 PSF / 2400Pa
  - c) Down-Slope Load – 15 PSF / 720 Pa
- Maximum Span = 6ft
- Use with a maximum over current protection device OCPD of 30A

### LABEL MARKINGS

- System fire class rating: See installation instructions for installation requirements to achieve a specified system fire class rating with Unirac .
- Unirac SUNFRAME MICRORAIL™ is listed to UL 2703.
- All splices within a system are shipped with marking indicating date and location of manufacture.



														
UNIRAC SFM    MM/YYYY CONFORMS TO UL STD 2703 PATENT PENDING UNIRAC MFR. N-N														
SYSTEM FIRE CLASS RATINGS. SEE INSTALLATION INSTRUCTIONS FOR INSTALLATION REQUIREMENTS TO ACHIEVE A SPECIFIED SYSTEM FIRE CLASS RATING WITH THIS PRODUCT.														
<b>2 INCH MINIMUM MODULE ENGAGEMENT</b>														

Module Manufacturer	Module Series	Part No.
Canadian Solar	CS6V-M	CS6V-XXXM
Canadian Solar	CS6P-P	CS6P-XXXP
Canadian Solar	CS6K-M	CS6K-XXXM
Canadian Solar	CS5A-M	CS5A-XXX, CS5A-XXXM
Canadian Solar	CS6K-MS	CS6K-XXX MS
Canadian Solar	CS6U-P	CS6U-XXXP
Canadian Solar	CS6U-M	CS6U-XXXM
Canadian Solar	CS6X-P	CS6X-XXXP
Canadian Solar	CS6P-M	CS6P-XXXM
Canadian Solar	CS6K-MS	CS6K-XXXMS
Canadian Solar	CS6K-M	CS6K-XXXM
Canadian Solar	CS6K-P	CS6K-XXXP
Canadian Solar	CS6P-M	CS6P-XXXM
JA Solar	JAP6	JAP6 60-XXX
JA Solar	JAM6	JAM6-60-XXX/SI
Jinko	JKM XXX P-60	JKM XXX P-60
Jinko	JKM XXX PP-60	JKM XXX PP-60
Jinko	JKM XXX M-60	JKM XXX M-60
Jinko	JKM xxx M-60B	JKM xxx M-60B
Jinko	JKMS xxx PP-60	JKMS xxx PP-60
Jinko	JKMS xxx P-60	JKMS xxx P-60
Kyocera	KU-60	KU26X-6MCA
LG	MonoX	LG XXX S1C-L4
LG	NeON	LG XXX N1C-G4
LG	LG Q1C-A5	LG xxx Q1C-A5
LG	LG Q1K-A5	LG xxx Q1K-A5
LG	LG N1K-A5	LG xxx N1K-A5
LG	LG N1C-A5	LG xxx N1C-A5
LG	LG S1C-A5	LG xxx S1C-A5
LG	LG A1C-A5	LG xxx A1C-A5
LG	LG N2T-A4	LG xxx N2T-A4
LG	LG N2T-A5	LG xxx N2T-A5
LG	LG N2W-A5	LG xxx N2W-A5
LG	LG S2W-A5	LG xxx S2W-A5

Module Manufacturer	Module Series	Part No.
Panasonic	VBHN SA16	VBHN 3xx SA16 (B)
Panasonic	VBHN SA15	VBHN xxx SA15 (B)
Q-Cells	B.LINE PLUS BFR G4.1	B.LINE PLUS BFR G4.1 XXX
Q-Cells	B.LINE PRO BFR G4.1	B.LINE PRO BFR G4.1 XXX
Q-Cells	Q.PLUS-G4	Q.PLUS-G4 XXX
Q-Cells	Q.PLUS BFR G4.1	Q.PLUS BFR G4.1 XXX
Q-Cells	Q.PLUS BFR G4.1/TAA	Q.PLUS BFR G4.1/TAA xxx
Q-Cells	Q.PLUS BFR G4.1/MAX	Q.PLUS BFR G4.1/MAX xxx
Q-Cells	Q.PRO-G4	Q.PRO-G4 XXX
Q-Cells	Q.PRO EC-G4.4	Q.PRO EC-G4.4 xxx
Q-Cells	Q.PRO BFR G4	Q.PRO BFR G4 xxx
Q-Cells	Q.PRO BFR G4.1	Q.PRO BFR G4.1 XXX
Q-Cells	Q.PRO BFR G4.3	Q.PRO BFR G4.3 XXX
Q-Cells	Q.PEAK-G4.1	Q.PEAK-G4.1 xxx
Q-Cells	Q.PEAK- G4.1/MAX	Q.PEAK- G4.1/MAX xxx
Q-Cells	Q.PEAK BLK G4.1	Q.PEAK BLK G4.1 xxx
Q-Cells	Q.PEAK-G4.1/TAA	Q.PEAK-G4.1/TAA xxx
Q-Cells	Q.PEAK BLK G4.1/TAA	Q.PEAK BLK G4.1/TAA xxx
Renesola	all 60 cell modules	Virtus II
Renesola	all 60 cell modules	156 Series
Suniva	MV Series 60	MXV XXX-60
Suniva	Optimus	OPT XXX-60-4-100
Sunpower	E-Series	E20-XXX-COM
Sunpower	X-Series	X21-XXX
Sunpower	X-Series	X22-XXX-C-AC
Sunpower	P-Series	SPR-P17-xxx-COM
Sunpower	**Evaluated with both the G3 and G5 frame**	
Trina	TSM-PA05	TSM-XXX PA05
Trina	TSM-PD05	TSM-XXX PD05
Trina	TSM-DD05	TSM-XXX DD05
Yingli	YGE	YL XXX P-29b

XXX denotes module wattage.

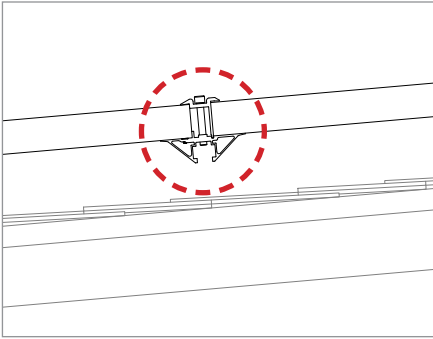

1. Loosen 9" splice bolts approximately 3 turns. **DO NOT REMOVE.**

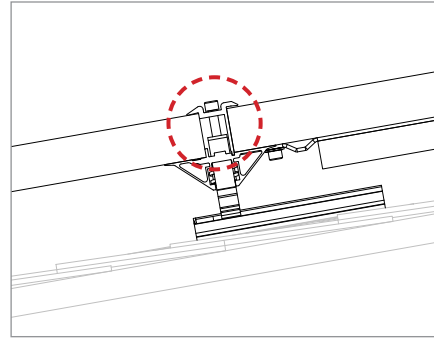

2. Remove bolts and caps from 3" Microrails and attached splices

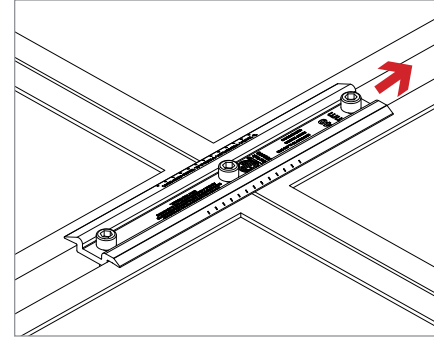

3. Slide splices away from the module to be removed

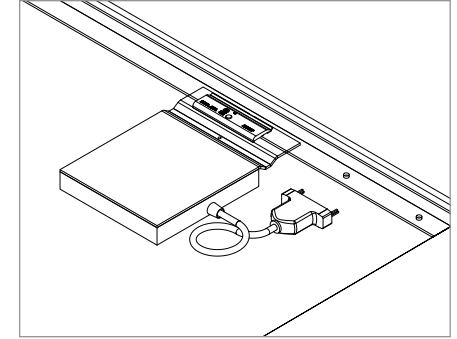

4. Lift module and disconnect MLPE cables

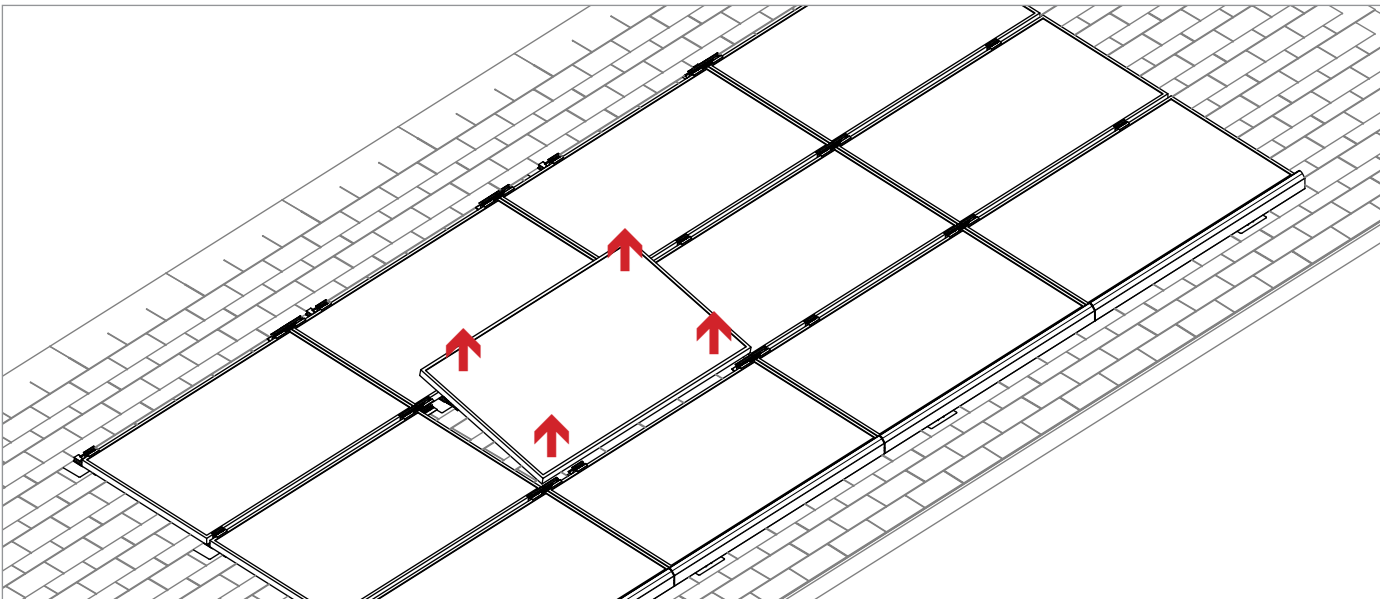

5. Remove Module. Reverse steps to replace module removed.

Bonding note: If both sides of array are bonded with NS Bonding Clips, as recommended, then no additional bonding is required for module maintenance.



If necessary, on the row of modules containing the module being removed, one additional bonding clip can be added to the edge of the array opposite of the edge with bonding clips already installed.

---

## **ELECTRICAL CONSIDERATIONS**

SUNFRAME Microrail is intended to be used with PV modules that have a system voltage less than or equal to that allowable by the NEC. A minimum 10AWG, 105°C copper grounding conductor should be used to ground a system, according to the National Electric Code (NEC). It is the installer's responsibility to check local codes, which may vary.

## **INTERCONNECTION INFORMATION**

There is no size constraint beyond structural thermal expansion limits on how many SUNFRAME Microrails & PV modules can be mechanically interconnected for any given configuration, provided that the installation meets the requirements of applicable building and fire codes.

**GROUNDING NOTES:** The installation must be conducted in accordance with the National Electric Code (NEC) and the authority having jurisdiction. Please refer to these resources in your location for required grounding lug quantities specific to your project. The grounding / bonding components may overhang parts of the array so care must be taken when walking around the array to avoid damage. Conductor fastener torque values depend on conductor size. See product data sheets for correct torque values. This racking system may be used to ground and/or mount a PV module complying with UL 1703 only when the specific module has been evaluated for grounding and/or mounting in compliance with the included instruction

**PERIODIC INSPECTION:** Conduct periodic inspections for loose components, loose fasteners or any corrosion, immediately replace any affected components.