



Owners Manual
For
PWRcell Automatic Transfer Switch

100 - 200 Amp, Service Entrance / 100 amp Non-Service Entrance

Model Number

CXSC100A3

(Non-service Entrance Rated)

CXSW100A3

(Service Entrance Rated with Utility Service Circuit Breaker)

CXSW200A3

(Service Entrance Rated with Utility Service Circuit Breaker)

SERIAL NUMBER: _____

DATE PURCHASED: _____

Register your product at <https://register.generac.com>

WWW.GENERAC.COM
888-436-3722

Para español , visita: <http://www.generac.com/service-support/owner-support>

Pour le français, visiter : <http://www.generac.com/service-support/owner-support>

SAVE THIS MANUAL FOR FUTURE REFERENCE

 **WARNING**

CANCER AND REPRODUCTIVE HARM

www.P65Warnings.ca.gov

(000393a)

Table of Contents

Section 1: Safety

Introduction	1
Safety Rules	1
Safety Symbols and Meanings	1
Electrical Hazards	2
General Hazards	3

Section 2: General Information

Applications	5
Unpacking	5
Equipment Description	5
Transfer Switch Mechanism	5
Utility Service Circuit Breaker (if equipped)	6
Transfer Switch Data Decal	6
Transfer Switch Enclosure	6
Safe Use of Transfer Switch	6
Load Management Options	6
PWRcell ATS Controller	6
Smart Management Module (SMM)	7
Application Considerations	7
Current Transformers	8

Section 3: Installation

Introduction to Installation	9
Inverter Versions Compatibility	9
Mounting	9
Open Enclosure	9
Connecting Utility and Standby Power	10
Connecting the ATS Control Cable	11
Connecting the Current Transformer (CTs)	14
Connecting PWRcell ATS Controller	14
Control of Air Conditioner Load	14
Connecting the Grid Sense Wires	14
Manual Override Button	14
Configuring the Inverter	14
Fault Current Label	15

Section 4: Operation

Functional Tests and Adjustments	17
Manual Operation	17
Close to Utility Source Side	17
Close to Inverter Source Side	18
Return to Utility Source Side	18
Voltage Checks	18
Utility Voltage Checks	18
Inverter Voltage Checks	18
PWRcell Voltage Tests	18
Inverter Tests Under Load	18
Maintenance	19
Testing the PWRcell ATS Controller	19
PWRcell ATS Controller Fuse Service	19
Testing The SMM	19

Section 5: Drawings and Diagrams

Installation Drawings	21
Interconnection Drawings	23

This page intentionally left blank.

Section 1: Safety

Introduction

Thank you for purchasing a Generac product. This unit has been designed to provide high performance, efficient operation, and years of use when maintained properly.



WARNING

Consult Manual. Read and understand manual completely before using product. Failure to completely understand manual and product could result in death or serious injury. (000100a)

Read this manual thoroughly and understand all of the instructions, cautions, and warnings before using this equipment. If any section of the manual is not understood, contact your nearest authorized dealer, or contact Generac Customer Service at www.Generac.com, or call 888-436-3722 with any questions or concerns.

The owner is responsible for proper maintenance and safe use of the equipment. Before operating or servicing this transfer switch:

- Study all warnings in this manual and on the product carefully.
- Become familiar with this manual and the unit before use.
- Refer to the installation sections of the manual for instructions on final assembly procedures. Follow the instructions completely.

Save these instructions for future reference. ALWAYS supply this manual to any individual that will use this equipment.

The information in this manual is accurate based on products produced at the time of publication. The manufacturer reserves the right to make technical updates, corrections, and product revisions at any time without notice.

Safety Rules

The manufacturer cannot anticipate every possible circumstance that might involve a hazard. The warnings in this manual, and on tags and decals affixed to the unit are, therefore, not all inclusive. If using a procedure, work method or operating technique that the manufacturer does not specifically recommend, verify that it is safe for others. Also make sure the procedure, work method or operating technique utilized does not render the equipment unsafe.

Safety Symbols and Meanings

Throughout this publication, and on tags and decals affixed to the transfer switch, DANGER, WARNING, CAUTION and NOTE blocks are used to alert personnel to special instructions about a particular operation that may be hazardous if performed incorrectly or carelessly. Observe them carefully. Their definitions are as follows:

DANGER

Indicates a hazardous situation which, if not avoided, will result in death or serious injury.

(000001)

WARNING

Indicates a hazardous situation which, if not avoided, could result in death or serious injury.

(000002)

CAUTION

Indicates a hazardous situation which, if not avoided, could result in minor or moderate injury.

(000003)

NOTE: Notes contain additional information important to a procedure and will be found within the regular text of this manual.

These safety alerts cannot eliminate the hazards that they indicate. Common sense and strict compliance with the special instructions while performing the action or service are essential to preventing accidents.

Electrical Hazards



⚠ DANGER

Electrocution. High voltage is present at transfer switch and terminals. Contact with live terminals will result in death or serious injury.

(000129)



⚠ DANGER

Electrocution. Water contact with a power source, if not avoided, will result in death or serious injury.

(000104)



⚠ DANGER

Electrocution. In the event of electrical accident, immediately shut power OFF. Use non-conductive implements to free victim from live conductor. Apply first aid and get medical help. Failure to do so will result in death or serious injury.

(000145)

⚠ DANGER

Electrical backfeed. Use only approved switchgear to isolate generator from the normal power source. Failure to do so will result in death, serious injury, and equipment damage.

(000237)



⚠ DANGER

Electrocution, equipment and property damage. Handle transfer switches carefully when installing. Never install a damaged transfer switch. Doing so could result in death or serious injury, equipment and property damage.

(000195)



⚠ DANGER

Electrocution. Turn utility supply OFF before working on utility connections of the transfer switch. Failure to do so will result in death or serious injury.

(000123)



⚠ DANGER

Electrocution. Do not disable or modify the connection box door safety switch. Doing so will result in death or serious injury.

(000157)

⚠ DANGER

Automatic start-up. Disconnect utility power and render unit inoperable before working on unit. Failure to do so will result in death or serious injury.

(000191)

⚠ DANGER

Equipment malfunction. Installing a dirty or damaged transfer switch will cause equipment malfunction and will result in death or serious injury.

(000119)

⚠ WARNING

Electric shock. Only a trained and licensed electrician should perform wiring and connections to unit. Failure to follow proper installation requirements could result in death, serious injury, and equipment or property damage.

(000155a)

⚠ CAUTION

Equipment damage. Verify all conductors are tightened to the factory specified torque value. Failure to do so could result in damage to the switch base.

(000120)

⚠ CAUTION

Equipment damage. Perform functional tests in the exact order they are presented in the manual. Failure to do so could result in equipment damage.

(000121)

⚠ CAUTION

Equipment damage. Exceeding rated voltage and current will damage the auxiliary contacts. Verify that voltage and current are within specification before energizing this equipment.

(000134a)

General Hazards

⚠ DANGER

Electrical backfeed. Use only approved switchgear to isolate generator from the normal power source. Failure to do so will result in death, serious injury, and equipment damage. (000237)



⚠ DANGER

Electrocution. High voltage is present at transfer switch and terminals. Contact with live terminals will result in death or serious injury. (000129)



⚠ DANGER

Electrocution. Turn utility supply OFF before working on utility connections of the transfer switch. Failure to do so will result in death or serious injury. (000123)



⚠ DANGER

Electrocution. Water contact with a power source, if not avoided, will result in death or serious injury. (000104)



⚠ DANGER

Electrocution. Do not wear jewelry while working on this equipment. Doing so will result in death or serious injury. (000188)



⚠ DANGER

Electrocution. Only authorized personnel should access transfer switch interior. Transfer switch doors should be kept closed and locked. Failure to do so will result in death or serious injury. (000213)

⚠ DANGER

Automatic start-up. Disconnect utility power and render unit inoperable before working on unit. Failure to do so will result in death or serious injury. (000191)



⚠ DANGER

Electrocution. In the event of electrical accident, immediately shut power OFF. Use non-conductive implements to free victim from live conductor. Apply first aid and get medical help. Failure to do so will result in death or serious injury. (000145)



⚠ WARNING

Loss of life. This product is not intended to be used in a critical life support application. Failure to adhere to this warning could result in death or serious injury. (000209b)

⚠ WARNING

Equipment damage. This unit is not intended for use as a prime power source. It is intended for use as an intermediate power supply in the event of temporary power outage only. Doing so could result in death, serious injury, and equipment damage. (000247a)

- Competent, qualified personnel should install, operate and service this equipment. Adhere strictly to local, state and national electrical and building codes. When using this equipment, comply with regulations established by the National Electrical Code (NEC), CSA Standard; the Occupational Safety and Health Administration (OSHA), or the local agency for workplace health and safety.
- If working on this equipment while standing on metal or concrete, place insulative mats over a dry wood platform. Work on this equipment only while standing on such insulative mats.
- Never work on this equipment while physically or mentally fatigued.
- Any voltage measurements should be performed with a meter that meets UL3111 safety standards, and meets or exceeds overvoltage class CAT III.

This page intentionally left blank.

Section 2: General Information

Applications

The PWRcell Automatic Transfer Switch (ATS) can be utilized with a PWRcell Energy Storage System (ESS) alone, or in conjunction with a Generator.

When used with a PWRcell ESS alone, it enables the entire home to be powered from the ESS, within the limits of it's power capacity. To ensure your PWRCell is protected from being overloaded, see section, [Load Management Options](#).

PWRcell ATS Controller also enables other advanced applications not covered in this manual. For more information, and to access the most up to date version of this owner's manual, visit <http://www.generac.com/service-support/owner-support>.

Unpacking

Carefully unpack the transfer switch. Inspect closely for any damage that might have occurred during shipment. The purchaser must file with the carrier any claims for loss or damage incurred while in transit.

Check that all packing material is completely removed from the switch prior to installation.

The kit should include:

- Manual Operating Handle
- Storage Bracket for Manual Operating Handle
- Fault Current Label

Equipment Description

This automatic transfer switch is used for transferring electrical load from a utility (normal) power source to a ESS (standby) power source.

Transfer of electrical loads occurs automatically when the utility power source has failed or is substantially reduced and the ESS is ready to power the home.

The transfer switch prevents electrical feedback between two different power sources (such as the utility and ESS sources) and, for that reason, codes require it in all standby electric system installations.

The transfer switch consists of a transfer mechanism, utility service disconnect circuit breaker (if equipped), and a PWRcell ATS Controller for inverter connections and management of HVAC loads.

Transfer Switch Mechanism

See [Figure 2-1](#). This switch is used with a single-phase system when the single-phase neutral line is to be connected to a neutral lug and is not to be switched.

Solderless, screw-type terminal lugs are standard.

The conductor size range is as follows:

Switch Rating	Wire Range	Conductor Tightening Torque
100A	#14-1/0 AWG (Cu/Al)	50 in-lbs (5.6 Nm)
200A	#6-250 MCM (Cu/Al)	275 in-lbs (31 Nm)

This transfer switch is suitable for control of motors, electric discharge lamps, tungsten filament and electric heating equipment where the sum of motor full load ampere ratings and the ampere ratings of other loads do not exceed the ampere rating of the switch and the tungsten load does not exceed 30 percent of the switch rating.

This UL listed transfer switch is for use in optional standby systems only (NEC article 702).

A 100A rated switch is suitable for use on circuits capable of delivering not more than 10,000 RMS symmetrical amperes, 250 VAC maximum, when protected by a 100A maximum circuit breaker (Siemens types QP or BQ) or 100A maximum circuit breaker (Square D Q2, Westinghouse CA-CAH, General Electric TQ2 and Siemens QJ2).

A 200A rated switch is suitable for use on a circuit capable of 22,000 RMS symmetrical amperes, 240 VAC when protected by a circuit breaker without an adjustable short time response or by fuses.

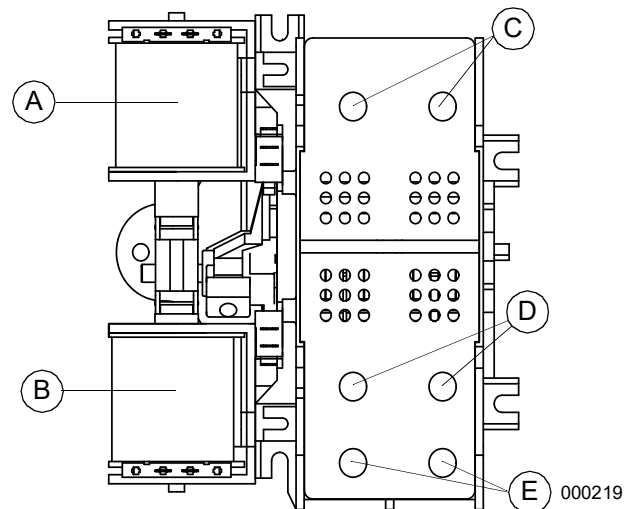

Figure 2-1. Typical Single-Phase ATS Transfer Mechanism

A	Utility Closing Coil
B	Standby Closing Coil
C	Utility Lugs (N1 & N2)
D	Standby Source Lugs (E1 & E2)
E	Load Lugs (T1 & T2)

Utility Service Circuit Breaker (if equipped)

The utility service and generator disconnect circuit breakers for 100 amp models are:

- Type BQ, 2-pole
- 10,000 A/C
- 120/240VAC, 100A
- 50/60 Hertz
- Wire range: #1 - #8 AWG (Cu/Al)
- The conductor tightening torque is 50 **in-lbs.** (5.6 Nm).

The utility service circuit breakers for 200 amp models are:

- Type 225AF, 2-pole
- 22,000 A/C
- 120/240VAC, 150A/200A
- 50/60 Hertz
- Wire range:
 - Line: 300 MCM - 6 STR (Cu/Al)
 - Load - ATS: 250 MCM - 6 STR (Cu/Al)
- The conductor tightening torque is:
 - Line: 375 **in-lbs** (42.4 Nm)
 - Load - ATS: 275 **in-lbs.** (31 Nm)

Transfer Switch Data Decal

A data decal is permanently affixed to the transfer switch enclosure. Use this transfer switch only with the specific limits shown on the data decal and on other decals and labels that may be affixed to the switch. This will prevent damage to equipment and property.

When requesting information or ordering parts for this equipment, make sure to include all information from the data decal.

For future reference, record the Model and Serial numbers in the space provided on the front cover of this manual.

Transfer Switch Enclosure

The standard switch enclosure is a National Electrical Manufacturer's Association (NEMA) and UL 3R type. UL and NEMA 3R (indoor/outdoor rated) type enclosures primarily provide a degree of protection against falling rain and sleet; are undamaged by the formation of ice on the enclosure.

Safe Use of Transfer Switch



Consult Manual. Read and understand manual completely before using product. Failure to completely understand manual and product could result in death or serious injury. (000100a)

Before installing, operating or servicing this equipment, read the **Safety Rules** carefully. Comply strictly with all **Safety Rules** to prevent accidents and/or damage to the equipment. The manufacturer recommends that a copy of the **Safety Rules** be posted near the transfer switch. Also, be sure to read all instructions and information found on tags, labels and decals affixed to the equipment.

Two publications that outline the safe use of transfer switches are the following:

- NFPA 70; National Electrical Code
- UL 1008: Standard for Safety—Automatic Transfer Switches

NOTE: It is essential to use the latest version of any standard to guarantee correct and current information.

Load Management Options

Load management systems are designed to work together to prevent a generator or ESS from being overloaded by large appliance loads. A PWRcell ATS Controller is provided as standard equipment with this switch. An optional Smart Management Module (SMM) is also available.

PWRcell ATS Controller

Up to four air conditioner loads can be managed by the PWRcell ATS Controller. The controller manages the loads by “shedding” the connected loads in the event of a drop in system frequency (overload). Loads to be “shed” are in 4 priority levels on the module. For assistance with system design please call Generac Clean Energy Inside Sales, 1-855-635-5186, ext 1861

See **Figure 2-2**. Priorities A/C 1-4 (A) have connections for an air conditioner. To control an air conditioner, no additional equipment is required. Internal normally closed relays interrupt the 24 VAC thermostat control signal to disable the air conditioner load.

Four LEDs, located on the PWRcell ATS Controller (B),

illuminate when a load is connected and powered.

See [Figure 2-2](#). The controller has a test button (C) used to simulate an overload condition. This button operates even when the transfer signal is inactive.

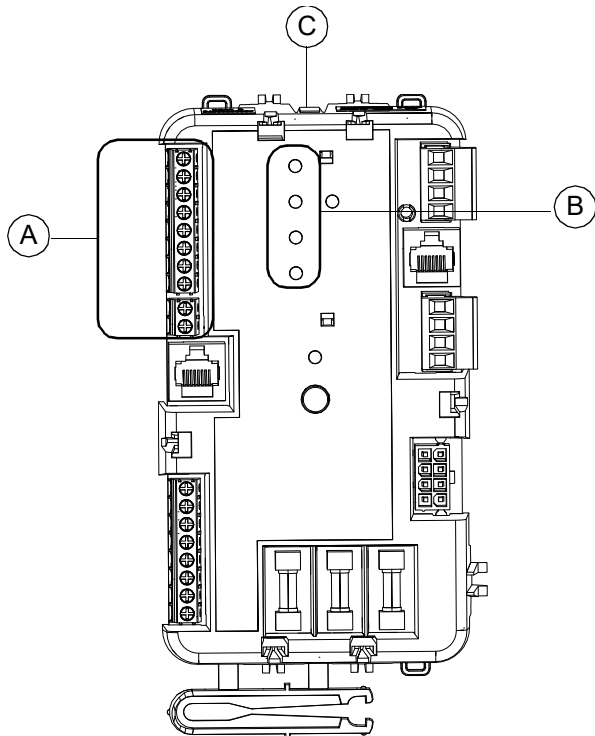

011166

Figure 2-2. PWRcell ATS Controller

**Smart Management Module (SMM)
(sold separately)**

Any loads, including central air conditioners, can be managed using a Smart Management Module (SMM). The system can accommodate up to eight individual SMMs.

NOTE: SMMs are self-contained and have individual built-in controllers and are wired in series with the 240V branch circuit wiring between the circuit breaker and the managed load.

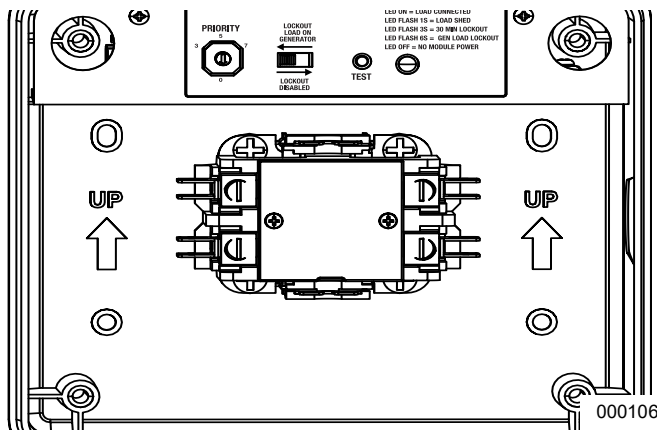

Figure 2-3. Smart Management Module (SMM)

Application Considerations

An overload condition is determined by the PWRcell inverter frequency while the inverter is in island mode. Loads are managed and de-energized when frequency is less than 58 Hz for three seconds or less than 50 Hz for ½ second (for 60 Hz systems).

The controller can be used in conjunction with individual SMMs to manage a combined total of eight loads.

- The priority order determines the order in which managed loads are re-energized by the load management system after all of the managed loads have been de-energized due to an overload condition.
- Use Priorities A/C 1-4 on the controller as the top priorities, then up to four SMMs as Priorities 5-8.
- Use only select A/C priorities on the controller as the top priorities, then use additional SMMs as the remaining priorities.
- A SMM can share a priority with an A/C priority on the controller provided the standby power source is sized to handle the combined surge load from both appliances. Sharing priorities can allow up to 12 loads to be managed in a properly sized system.

In any combination of modules, the recovery times after a loss of utility power or shutdown due to overload are shown in Table 1: [Priority Settings](#).

Table 1. Priority Settings

Priority	Recovery Time	PWRcell ATS Controller	SMM
1	5 minutes	Yes	Yes
2	5 minutes 15 seconds	Yes	Yes
3	5 minutes 30 seconds	Yes	Yes
4	5 minutes 45 seconds	Yes	Yes
5	6 minutes	NA	Yes
6	6 minutes 15 seconds	NA	Yes
7	6 minutes 30 seconds	NA	Yes
8	6 minutes 45 seconds	NA	Yes

Refer to the SMM Owner's/Installation Manual for detailed characteristics and specifications of that product.

Current Transformers

Current Transformers are provided with the PWRcell Inverter and allow the inverter to measure the flow of power to and from the home. The PWRcell ATS Controller provides connections for these CTs (A), and for CT measurements to be sent back to the inverter (B).

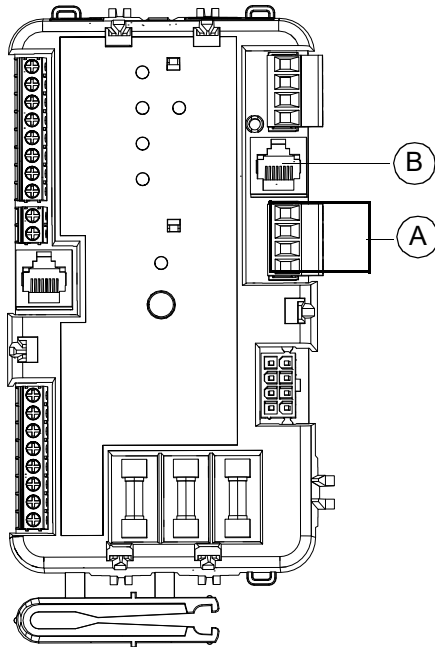

011166

Figure 2-4. CT Input and CT Output (Inverter)

A	CT Input (From CTs)	B	CT Output (To Inverter)
---	---------------------	---	-------------------------

Section 3: Installation

Introduction to Installation

This equipment has been wired and tested at the factory. Installing the switch includes the following procedures:

- Mounting the enclosure.
- Connecting power source and load leads.
- Connecting the PWRcell inverter control conductors.
- Installing the current transformers.
- Connecting the PWRcell ATS Controller.
- Configuring the inverter.

NOTE: Inner panel (E) is ONLY on Service Entrance Rated Models.

5. Loosen nut (F) until it clears t-slot (H) in inner panel.
6. Grasp inner panel at two cutouts (G—left and right). Tilt inner panel as shown, passing nut through t-slot.
7. Lower inner panel until clear of two retention slots (J—left and right sides), and pull away from enclosure.

Inverter Versions Compatibility

The PWRCell ATS is compatible with all versions of the PWRCell inverter, however some additional connections are necessary on the X7602 model compared to the XVT076A03. To determine the version of your inverter, refer to the product label on the bottom right hand side of the enclosure. You will see the model number “X7602” or “XVT076A03”. Note that some steps are marked “X7602 Only” - these are not required if you have the XVT076A03.

Mounting

Mounting dimensions for the transfer switch enclosure are in this manual. Enclosures are typically wall-mounted. See [Drawings and Diagrams](#).

DANGER

Equipment malfunction. Installing a dirty or damaged transfer switch will cause equipment malfunction and will result in death or serious injury.

(000119)

This transfer switch is mounted in a UL type 3R enclosure. It can be mounted outside or inside and should be based on the layout of installation, convenience and proximity to the utility supply and load center. Install the transfer switch as close as possible to the electrical loads that are to be connected to it. Mount the switch vertically to a rigid supporting structure. To prevent switch distortion, level all mounting points. If necessary, use washers behind mounting holes to level the unit.

Open Enclosure

See [Figure 3-1](#). First, remove outer cover (A):

1. Remove thumb screw (B).
2. Slide slot (C) over retention tab.
3. Lower cover until clear of top flange (D), and pull away from enclosure.
4. Remove inner panel (E).

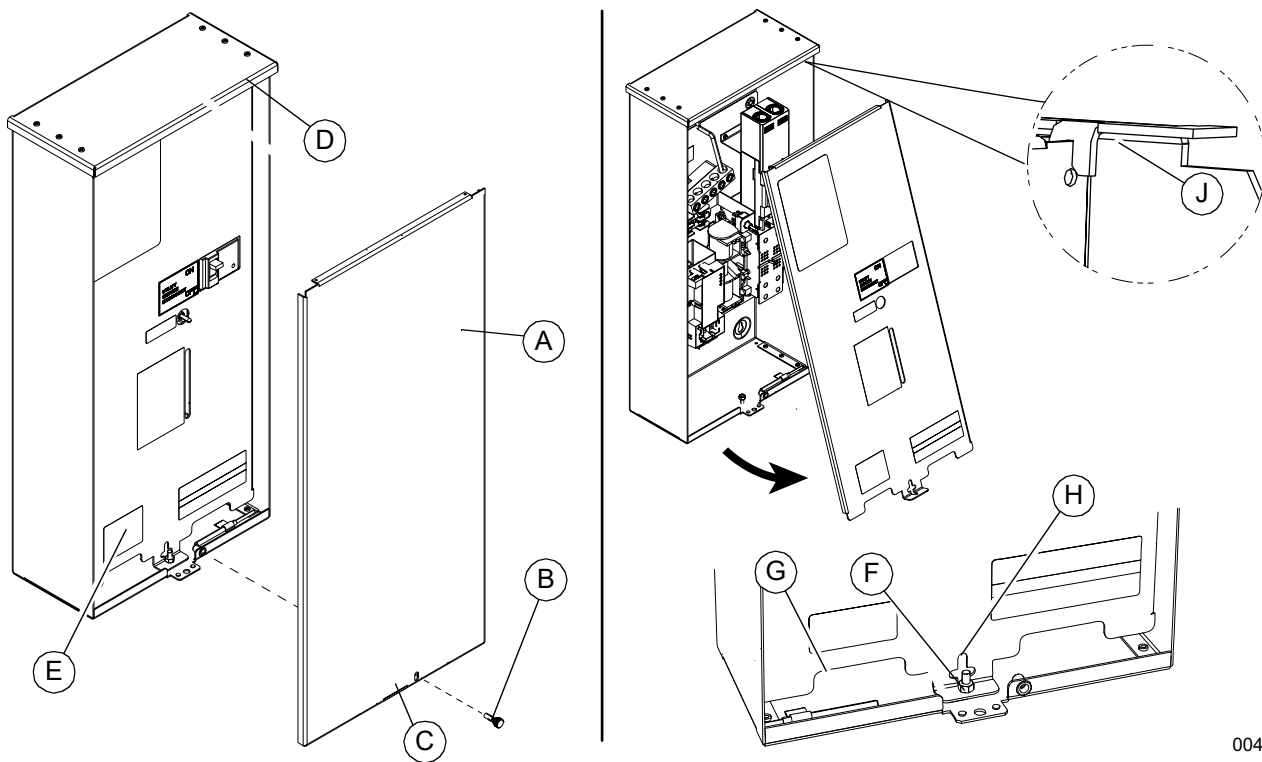

Figure 3-1. Open Enclosure

004397

Connecting Utility and Standby Power Sources



⚠ DANGER

Electrocution. Turn utility and emergency power supplies to OFF before connecting power source and load lines. Failure to do so will result in death or serious injury. (000116)

Installation and interconnection diagrams are provided in this manual.

NOTE: All installations must comply with national, state and local codes. It is the responsibility of the installer to perform an installation that will pass the final electrical inspection.

1. Remove the finger safe barrier covers and then connect utility supply at the utility service disconnect circuit breaker terminals N1 and N2. Follow torque specifications listed on the circuit breaker.
2. See [Figure 3-2](#). Connect utility neutral conductor to the neutral terminal bar. The grounding electrode conductors can be connected to the equipment grounding terminal bar (see NEC 250.24(A)(4)). Follow all torque specifications for the terminal bars. A wire type main bonding jumper is provided to properly bond the service equipment.

NOTE: A wire type main bonding jumper (A) is provided on 200 A units and 100 A Service

Entrance rated units. This bonding jumper can be removed if needed where the ATS is not installed as service equipment.

NOTE: Service entrance rated model will have a service disconnect in area (B) of [Figure 3-3](#).

3. Connect the inverter protected load ungrounded feeder conductors to terminals E1 and E2 on the transfer mechanism.
4. Connect the inverter protected load neutral conductor to the neutral terminal bar. Connect the inverter protected load equipment grounding conductor to the equipment grounding terminal bar. Follow all torque specifications for the terminal bars.
5. Connect a subpanel supply to lower T1 and T2 Terminals. Connect subpanel Neutral conductor to the neutral terminal bar and the equipment grounding conductor to the equipment ground. Copper or Aluminum conductors shall be sized in accordance with all applicable NEC requirements, and shall be permitted to be sized based on the 75°C column of Table 310.16 in the NEC. The installation must comply fully with all applicable codes, standards and regulations.

Knockouts into the transfer switch can be made in the field as needed for entry of power cables and conduit. Conduit entry shall maintain the proper wire bending spaces required by Tables 312.6 (A) and (B) in the NEC. For transfer switches installed in wet locations, power

cables or conduits entering above the level of uninsulated live parts shall use fittings listed for use in wet locations as required by 312.2 in the NEC.

NOTE: If aluminum conductors are used, apply corrosion inhibitor to conductors if required by the aluminum conductor manufacturer. After tightening terminal lugs, carefully wipe away any excess corrosion inhibitor.

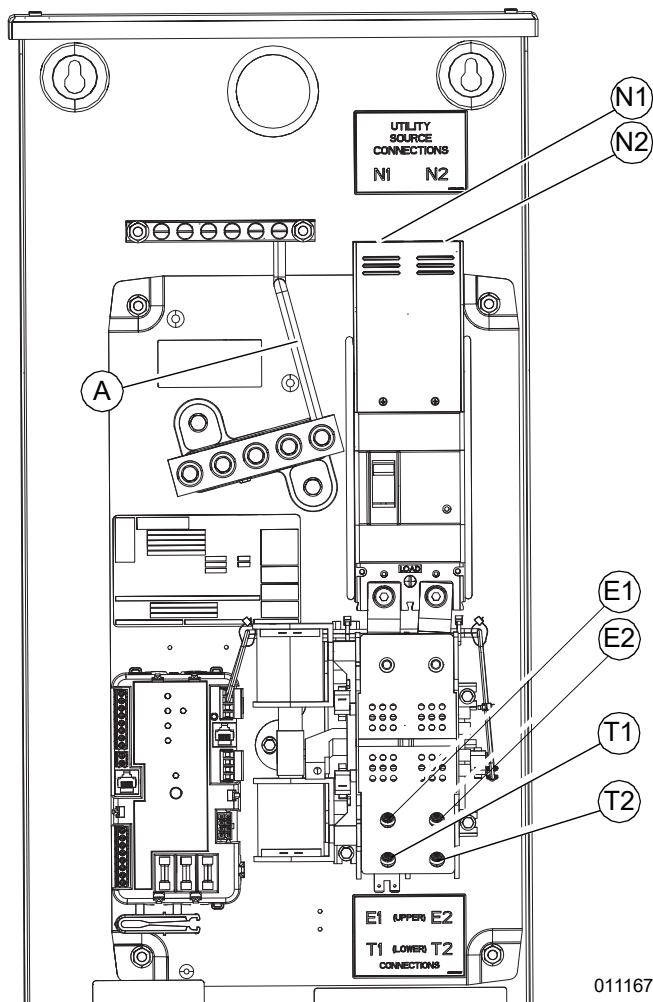

Figure 3-2. Wiring Connections 200 A Unit

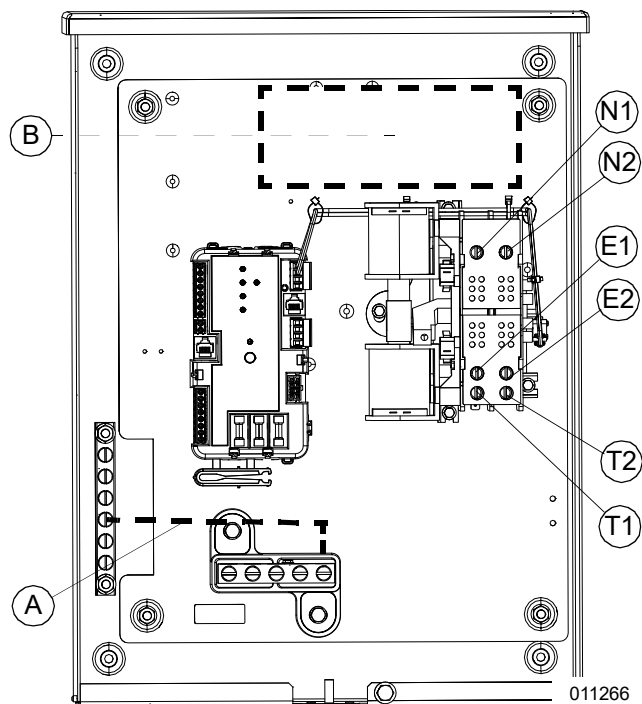

Figure 3-3. Wiring Connections 100 A Unit

Tighten terminal lugs to the torque values as noted on the decal located on the inside of the door. After tightening terminal lugs, carefully wipe away any excess corrosion inhibitor.

CAUTION

Equipment damage. Verify all conductors are tightened to the factory specified torque value. Failure to do so could result in damage to the switch base.

(000120)

Connecting the ATS Control Cable

Use a CAT-5 cable to connect the “Inverter ATS control” port on the controller to the “TRANS (ATS)” port on the Inverter. Use CAT-5 with 600V insulation, and route away from the Utility and Inverter supply conductors. See NEC Article 725.136(D) for more information on the installation requirements. See [Figure 3-4](#), [Figure 3-5](#), and [Figure 3-6](#).

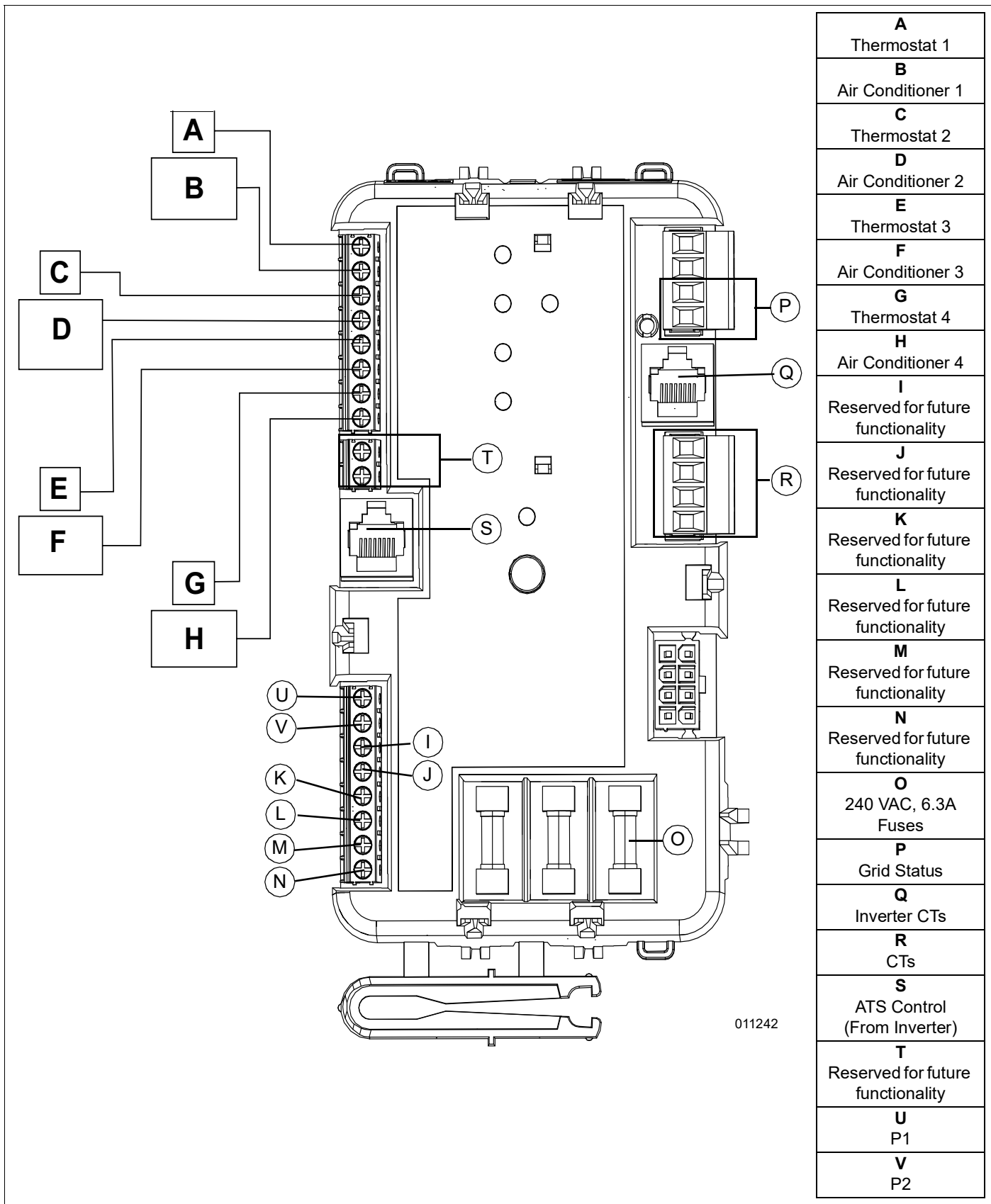
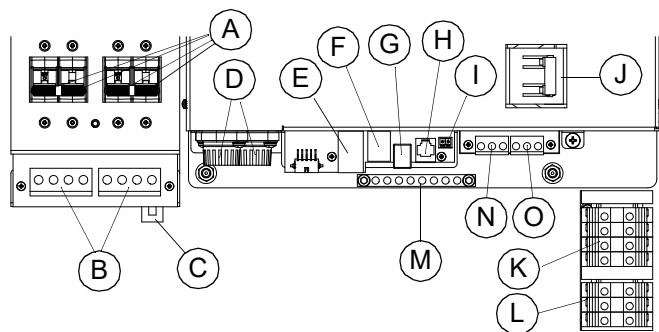
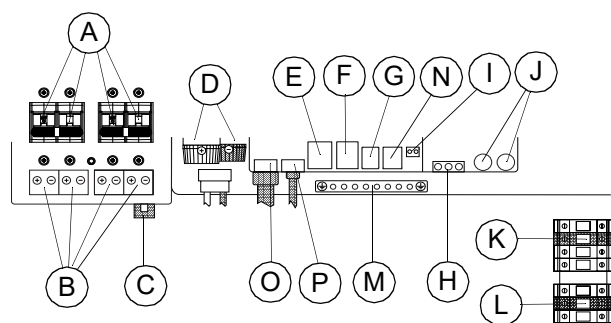

Figure 3-4. Controller Connections



009993

Figure 3-5. Inverter Connections for X7602



011201

Figure 3-6. Inverter Connections for XVT076A03

A	PWRcell DC disconnects	H	Service Port (Generac personnel only)
B	REbus bi-directional DC terminals	I	STOP terminals (external shutdown)
C	Internet connection	J	Protected loads disconnect
D	DC main fuses	K	AC grid connection terminals
E	Current Transformers (CTs) accessory ports	L	Protected loads terminals
F	Automatic Transfer Switches (ATS) accessory port	M	Grounding bar
G	REbus Beacon port	N	Gen Sense
O	Reserved for Future Functionality		

A	PWRcell DC disconnects	I	STOP terminals (external shutdown)
B	REbus bi-directional DC terminals	J	Fast Blow Fuses 1A 250V
C	Internet connection	K	AC grid connection terminals
D	DC main fuses	L	Protected loads terminals
E	Current Transformers (CTs) accessory ports	M	Grounding bar
F	Automatic Transfer Switches (ATS) accessory port	N	Service Port (Generac personnel only)
G	REbus Beacon port	O	Display
H	Reserved for Future Functionality	P	LTE

Connecting the Current Transformer (CTs)

Connect the CTs as shown in [Table 3-1](#) below. Clamp CT1 and CT2 around the wires connected to T1 and T2, respectively.

Table 3-1. CTs Connections

CT	Controller PORT	WIRE COLOR
1	CT1+	Yellow
1	CT1-	Green
2	CT2+	Yellow
2	CT2-	Green

Use a CAT-5 cable to connect the “Inverter CTs” port on the controller to the “CTs” port on the Inverter. Use CAT-5 with 600V insulation, and route away from the Utility and Inverter supply conductors. See [Figure 3-4](#), [Figure 3-5](#), and [Figure 3-6](#).

Connecting PWRcell ATS Controller

See [Figure 3-4](#). The PWRcell ATS controller can control an air conditioner (24 VAC) directly.

Control of Air Conditioner Load

1. Route the thermostat cable (from the furnace/ thermostat to the outdoor air conditioner unit) to the transfer switch.
2. Connect the wire to the terminal strip terminals (A/C 1) on the PWRcell ATS Controller as shown in [Figure 3-4](#). These are normally closed contacts which open upon load shed conditions. Route thermostat wire away from high voltage wires.
3. If required, connect additional air conditioners to the terminal strip terminals (A/C 2-4).

Contact Ratings	
A/C 1-4	24 VAC, 1.0 Amp Max

NOTE: These instructions are for a typical air conditioner installation. Control of certain heat pumps and 2-stage air conditioners may require special connections or the use of SMMs to control the loads.

Connecting the Grid Sense Wires

NOTE: This step is only required for the X7602. Skip if using the XVT076A03.

Connect two 14 - 18AWG 600V wires between the “Grid Status” port on the controller, and the Gen Sense port on the Inverter. Route away from the Utility and Inverter supply conductors. See [Figure 3-4](#) and [Figure 3-5](#).

Manual Override Button



DANGER

Electrocution. Only authorized personnel should access transfer switch interior. Transfer switch doors should be kept closed and locked. Failure to do so will result in death or serious injury. (000213)

See [Figure 3-7](#). A manual override button (A) is provided for diagnostics purposes. It should only be operated by qualified personnel when the panel is de-energized.

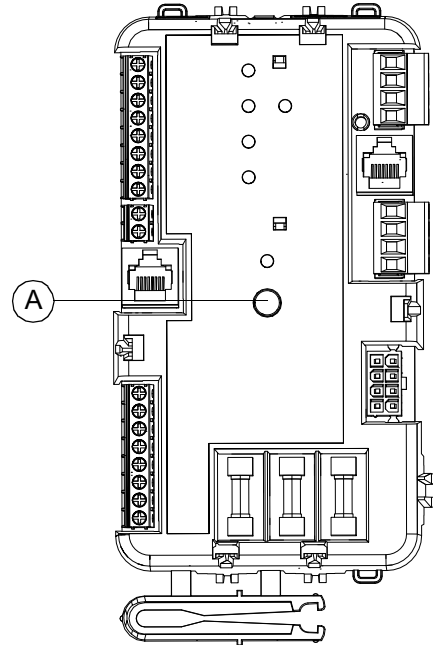

011166

Figure 3-7. Manual Override Button

During normal operation, the manual override button should be disengaged, with the red LED off. When engaged, the inverter will not be able to control the ATS.

Configuring the Inverter

Using the graphical interface on the Inverter, configure your inverter as shown below to enable control of the PWRCell ATS Controller.

Setpoint	Description	Default Value	Units
EnaEXT Transfer	Enable use of external ATS. Set “on” to enable ATS control.	off	–
Grid GoodTime	Minimum length of time that the grid must be stable before the inverter will toggle the ATS back to grid mode after an outage.	15	s
ExtTrans Volt	Minimum single-line (phase) grid voltage below which the inverter will toggle the ATS. If either line of the grid drops below this setpoint value and there is a grid fault, as defined by UL1741SA trip settings, then the inverter will toggle the ATS to backup mode.	95.0	V

Fault Current Label

See **Figure 3-8**. A Fault Current Identification Label is provided in the bag containing the unit Owner's Manual and transfer switch manual operating handle. The 2017 NEC requires that the short-circuit current rating of the transfer equipment, based on the type of overcurrent protective device protecting the transfer equipment, be field marked on the exterior of the transfer equipment. For NEC compliance, verify the required short-circuit current rating of the transfer switch before installation. The completed label provides the local AHJ (Authority Having Jurisdiction) with the information he or she may require during inspection.

Apply the label to the exterior of the transfer switch enclosure. Use a pen to fill in the required information, and then cover the label with the clear protective decal.

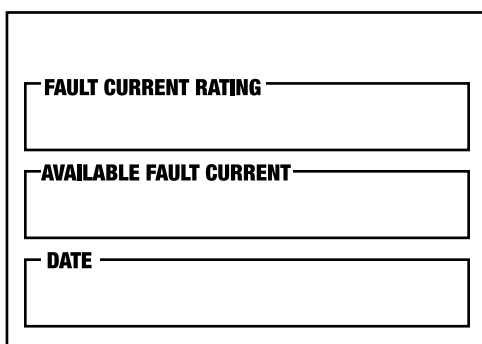

FAULT CURRENT RATING
AVAILABLE FAULT CURRENT
DATE

Figure 3-8. Fault Current Label

NOTE: The 2020 NEC does not require the use of this label for installations in one- and two-family dwelling units.

This page intentionally left blank.

Section 4: Operation

Functional Tests and Adjustments

Following transfer switch installation and interconnection, inspect the entire installation carefully. A competent, qualified electrician should inspect it. The installation should comply strictly with all applicable codes, standards, and regulations. When absolutely certain the installation is proper and correct, complete a functional test of the system.

CAUTION

Equipment damage. Perform functional tests in the exact order they are presented in the manual. Failure to do so could result in equipment damage.

(000121)

IMPORTANT: Before proceeding with functional tests, read and make sure all instructions and information in this section is understood. Also read the information and instructions of labels and decals affixed to the switch. Note any options or accessories that might be installed and review their operation.

Manual Operation



DANGER

Electrocution. Do not manually transfer under load. Disconnect transfer switch from all power sources prior to manual transfer. Failure to do so will result in death or serious injury, and equipment damage.

(000132)

NOTE: Be sure to remove handle from mechanism upon completion and before installation of protective covers.

See [Figure 4-1](#). A manual handle (B) is shipped with the transfer switch manual. Manual operation must be checked **BEFORE** the transfer switch is operated electrically. To check manual operation, proceed as follows:

1. Verify the inverter is in the OFF mode.
 2. Turn OFF both utility (service disconnect circuit breaker) and standby power supplies to the transfer switch.
 3. Note position of transfer mechanism main contacts (A) by observing the movable contact carrier arm. This can be viewed through the long narrow slot in the inside cover. The top of the movable contact carrier arm is yellow to be easily identified.
- Manual operation handle in the UP position - LOAD terminals (T1, T2) are connected to utility terminals (N1, N2).

- Manual operation handle in the DOWN position - LOAD terminals (T1, T2) are connected to STANDBY terminals (E1, E2).

CAUTION

Equipment damage. Do not use excessive force while manually operating the transfer switch. Doing so could result in equipment damage.

(000122)

Close to Utility Source Side

Before proceeding, verify the position of the switch by observing the position of manual operation handle (A) in [Figure 4-1](#). If the handle is UP, the contacts are closed in the utility (normal) position, no further action is required. If the handle is DOWN, proceed with Step 1.

1. With the handle inserted into the movable contact carrier arm, move handle UP. Be sure to hold on to the handle as it will move quickly after the center of travel.
2. Remove manual operating handle from movable contact carrier arm. Return handle to storage bracket.

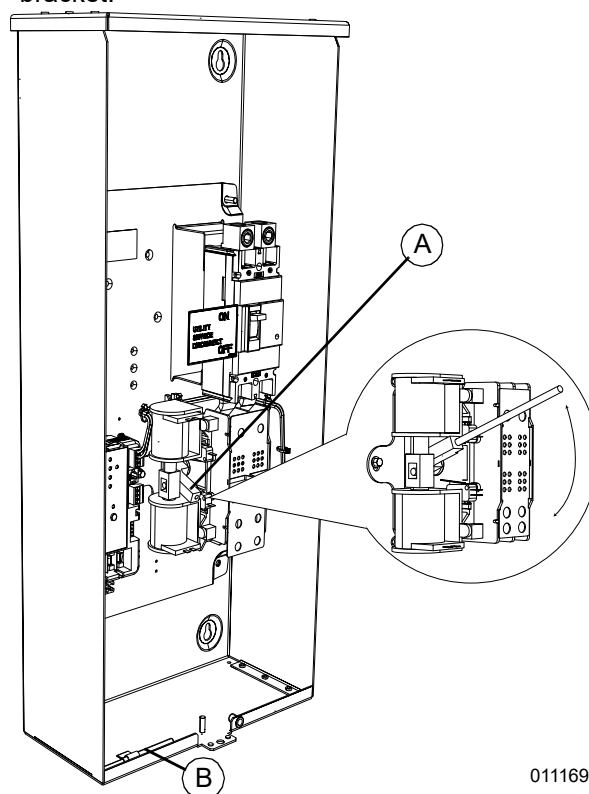

011169

Figure 4-1. Manual Operation

Close to Inverter Source Side

Before proceeding, verify the position of the switch by observing the position of the manual operation handle in **Figure 4-1**. If the handle is DOWN, the contacts are closed in the inverter (standby) position. No further action is required. If the handle is UP, proceed with Step 1.

1. With the handle inserted into the movable contact carrier arm, move the handle DOWN. Be sure to hold on to the handle as it will move quickly after the center of travel.
2. Remove manual operating handle from movable contact carrier arm. Return handle to storage bracket.

Return to Utility Source Side

1. Manually actuate switch to return manual operating handle to the UP position.
2. Remove manual operating handle from movable contact carrier arm. Return handle to storage bracket.

NOTE: Be sure to remove handle from mechanism upon completion and before installation of protective covers.

Voltage Checks

NOTE: Use the Digital Multimeter (DMM) LowZ low input impedance setting to collect accurate voltage measurements. LowZ eliminates the possibility of inaccurate ghost voltage readings, also known as phantom voltage or stray voltage readings. See DMM manufacturer’s literature for additional information.

Utility Voltage Checks

1. Turn ON the utility power supply to the transfer switch using the utility service disconnect circuit breaker.



⚠ DANGER

Electrocution. High voltage is present at transfer switch and terminals. Contact with live terminals will result in death or serious injury.

(000129)

2. With an accurate AC voltmeter, check for correct voltage. Measure across ATS terminal lugs N1 and N2; N1 to NEUTRAL and N2 to NEUTRAL.



⚠ DANGER

Electrocution. Turn utility supply OFF before working on utility connections of the transfer switch. Failure to do so will result in death or serious injury.

(000123)

Inverter Voltage Checks

1. Open all breakers in load center.
2. Open service entrance breaker in ATS or switch upstream of the ATS.
3. Inverter should switch the ATS and begin powering the load center.



⚠ DANGER

Electrocution. High voltage is present at transfer switch and terminals. Contact with live terminals will result in death or serious injury.

(000129)

4. Confirm voltage and frequency of each phase in load center using multimeter. Each phase should be between 118-124V, and 59.9-60.1Hz.
5. To end test, close the service entrance circuit breaker.

NOTE: Battery should be charged to at least 20% before performing this test.

PWRcell Voltage Tests

Inverter Tests Under Load

1. Open all breakers in load center except one dual-pole breaker of 20-30A.
2. Open service entrance breaker in ATS or switch upstream of the ATS.
3. Inverter should switch the ATS and begin powering the load center.



⚠ DANGER

Electrocution. High voltage is present at transfer switch and terminals. Contact with live terminals will result in death or serious injury.

(000129)

4. Check power output from inverter on the LCD interface on the inverter. If less than 1kW, close more breakers in load center until load reaches 1kW.
5. Confirm voltage and frequency of each phase in load center using multimeter. Each phase should be between 118-124V, and 59.9-60.1Hz.
6. To end test, close the service entrance circuit breaker, then the remaining breakers in the load center.

NOTE: Battery should be charged to at least 20% before performing this test.

Installation Summary

1. Verify the installation has been properly performed as outlined by the manufacturer and that it meets all applicable laws and codes.

2. Verify proper operation of the system as outlined in the appropriate installation and owner's manuals.
3. Educate the end-user on the proper operation, maintenance and service call procedures.

NOTE: The Utility Power Circuit Breaker in the transfer switch must be turned OFF to simulate a utility outage. Shutting off the main disconnect in a subpanel connected to the transfer switch will NOT simulate an outage.

Maintenance

⚠ DANGER

Automatic start-up. Disconnect utility power and render unit inoperable before working on unit. Failure to do so will result in death or serious injury.

(000191)

The PWRCell ATS requires no specific maintenance. See Section 4 of the PWRCell Owner's Manual for information about maintaining your PWRCell System.

Testing the PWRcell ATS Controller

A "Test" pushbutton is provided on top of the PWRcell ATS Controller to test the operation of the load shed functions. The test pushbutton will work when the ATS is in the utility or the inverter position.

1. Turn on the utility supply to the ATS.
2. Wait for 5 minutes.
3. Verify managed loads are powered and all LEDs illuminate on controller.
4. Press the TEST button on the controller.
5. Verify that all of the connected loads to be "shed" become disabled.
6. After five (5) minutes verify A/C 1 is energized and Status LED A/C 1 is ON.
7. After another 15 seconds, verify A/C 2 is energized and Status LED A/C 2 is ON.
8. After another 15 seconds, verify Load A/C 3 is energized and Status LED Load A/C 3 is ON.
9. After another 15 seconds, verify A/C 4 is energized and Status LED A/C 4 is ON.

PWRcell ATS Controller Fuse Service

See [Figure 4-2](#). A fuse removal and installation tool (A) is included in the controller housing.

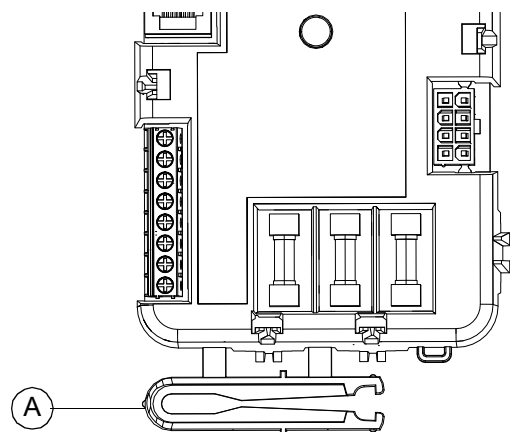

Figure 4-2. Fuse Removal and Installation Tool

If a fuse requires replacement, snap the tool free with an appropriate tool such as diagonal pliers, and use it to replace the fuse. The tool can be stored in the controller housing retainer directly above the fuses, with the large thumb tab facing out.

Use only Generac replacement fuses—part number 1000005117, rated 240 VAC, 6.3 Amps, 10,000 AIC.

Alternative fuses are Littelfuse® 021606.3MXP or Optifuse® FCD-6.3.

Testing The SMM

Refer to the SMM Owner's/Installation Manual for testing procedure.

This page intentionally left blank.

Section 5: Drawings and Diagrams

Installation Drawings

No. 0G6832-A: 100A SE & non-SE/150-200A non-SE

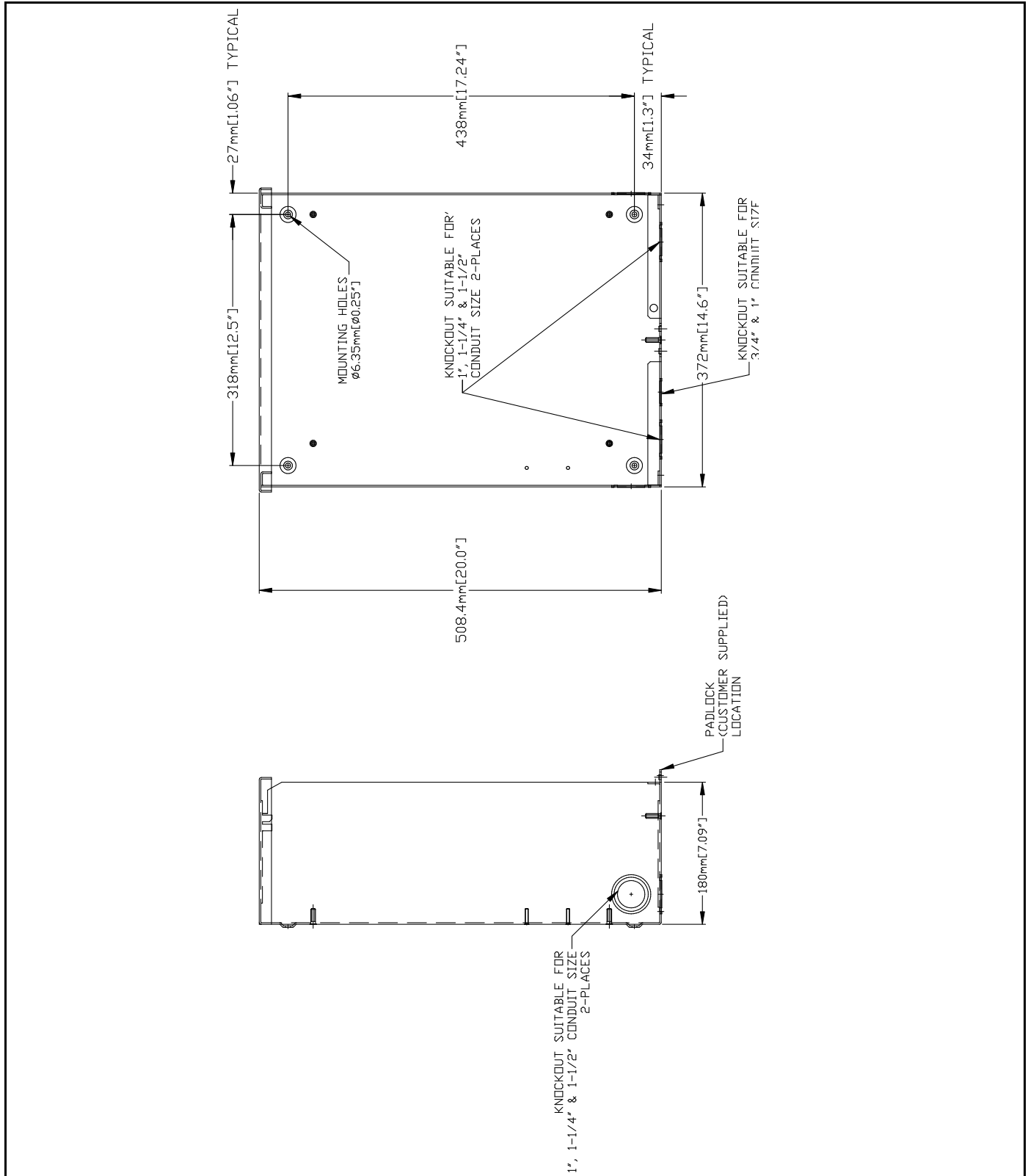

No.10000012171-A: 150/200A SE

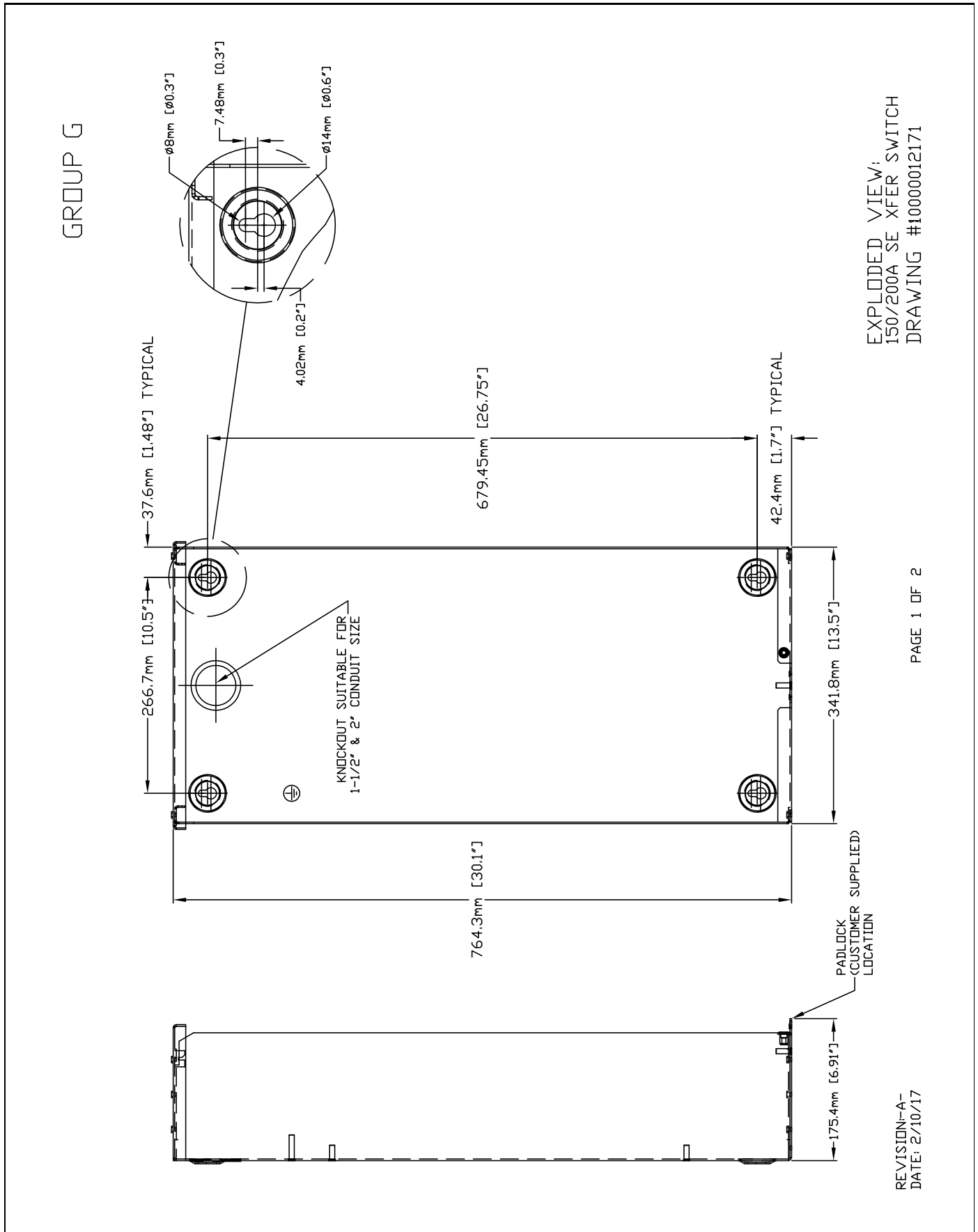

EXPLODED VIEW:
150/200A SE XFER SWITCH
DRAWING #10000012171

PAGE 1 OF 2

REVISION-A-
DATE: 2/10/17

Interconnection Drawings

No. A0000680537 (Part 1 of 4)—INTERCONNECTION XFER SW 100-200A—PWRcell Inverter

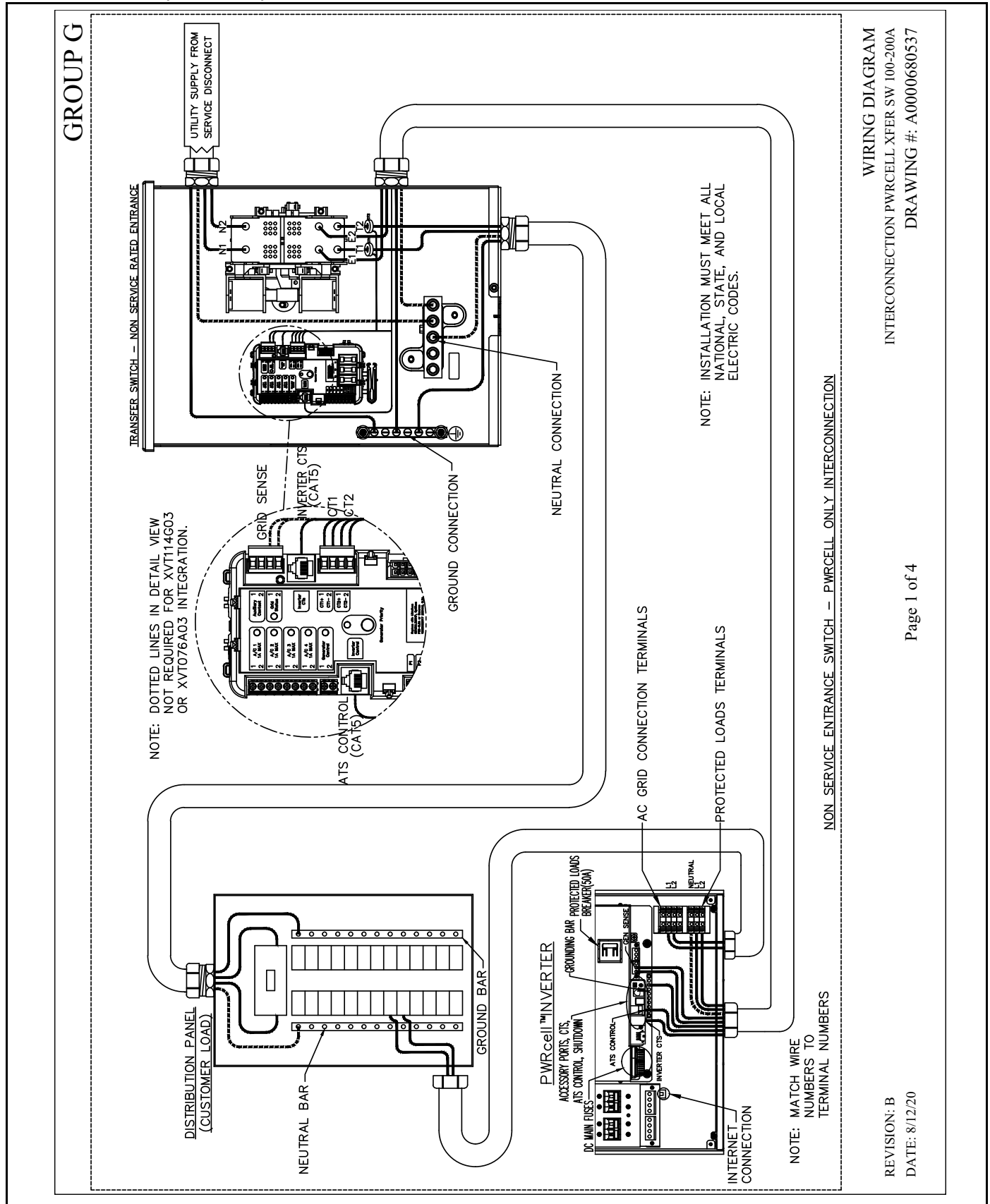

No. A0000680537 (Part 2 of 4)—INTERCONNECTION XFER SW 100-200A—PWRcell Inverter

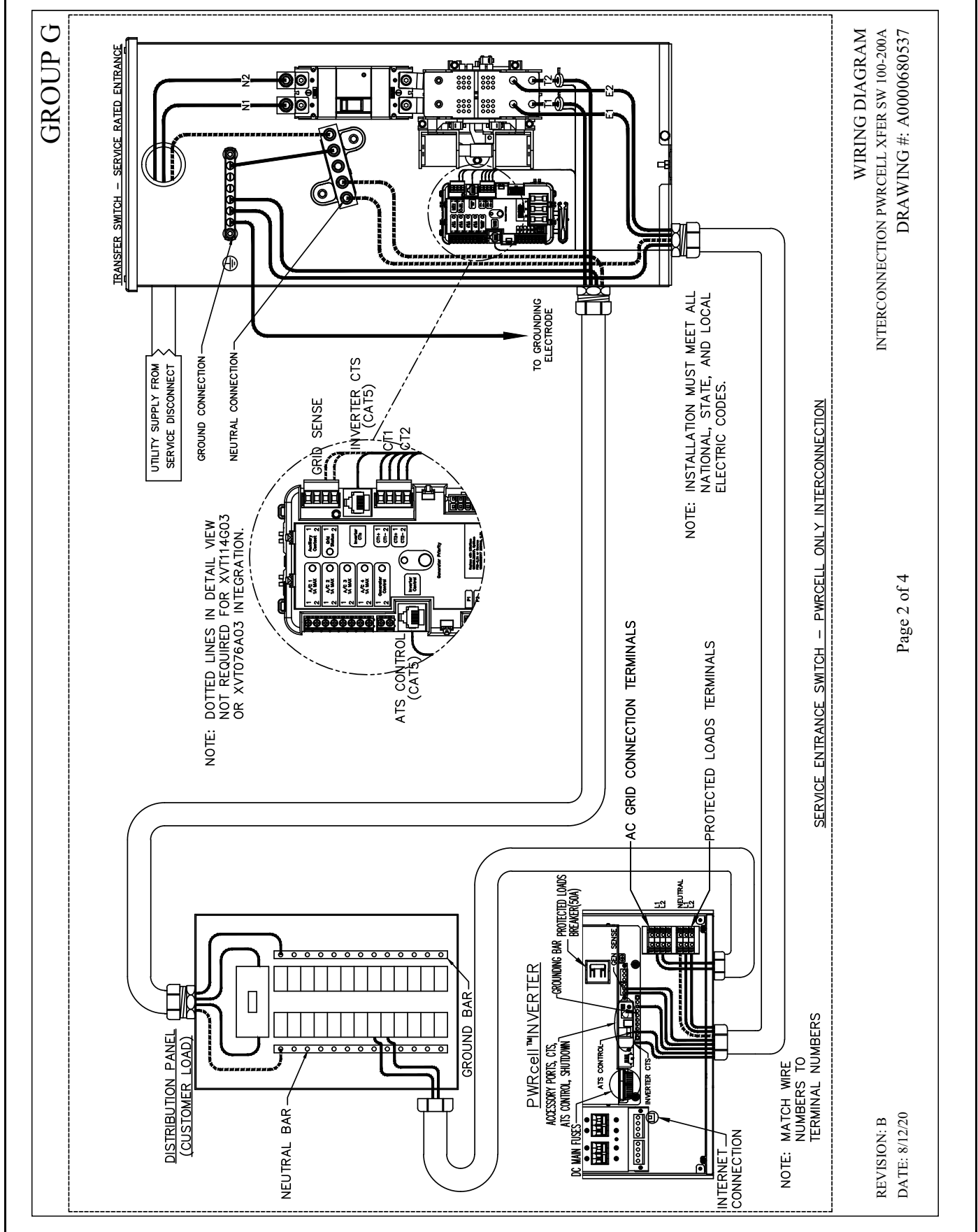

No. A000680537 (Part 3 of 4)—INTERCONNECTION XFER SW 100-200A—PWRcell Inverter

GROUP G

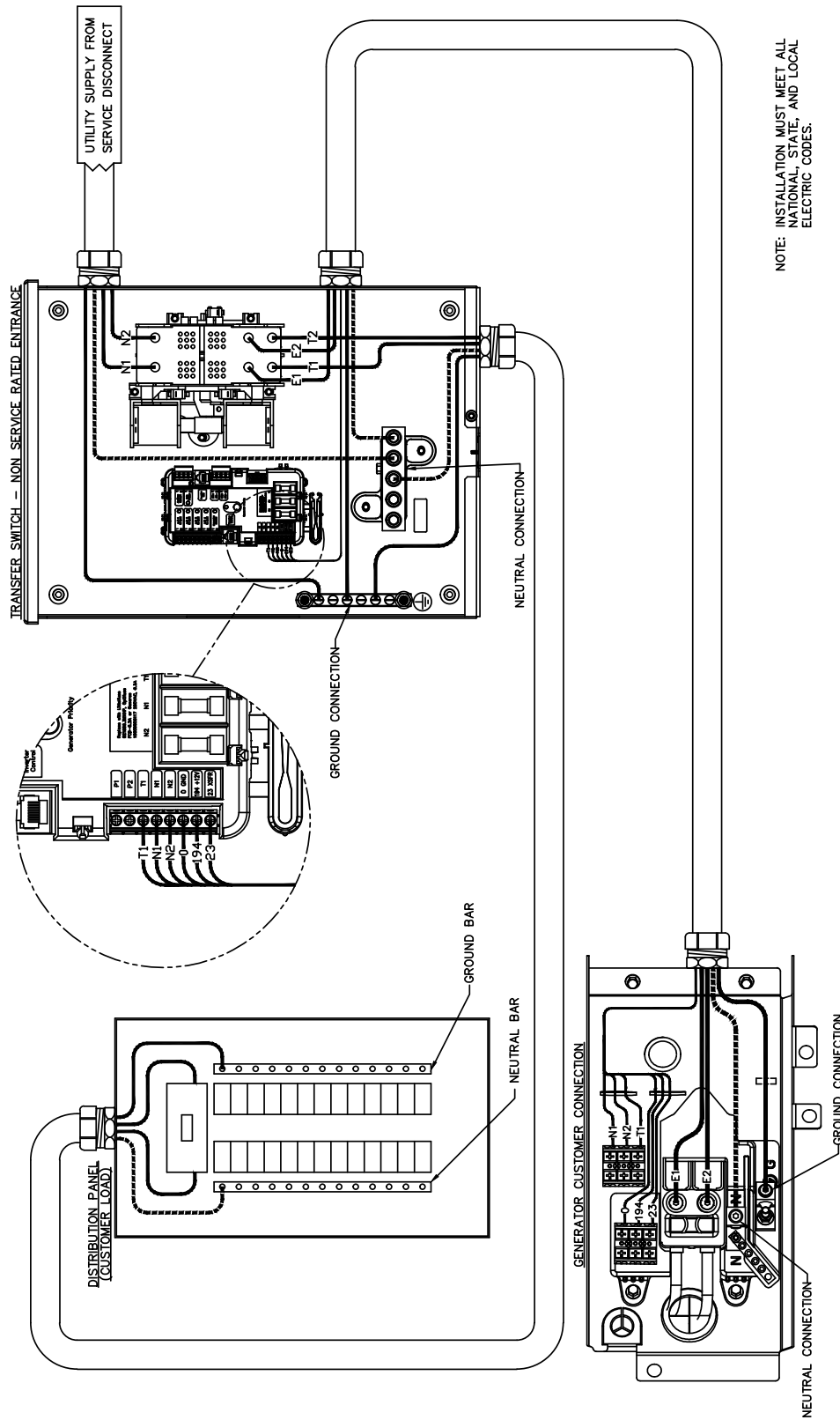

NON_SERVICE ENTRANCE_SWITCH -- GENERATOR_ONLY INTERCONNECTION

WIRING DIAGRAM
 INTERCONNECTION PWRCELL XFER SW 100-200A
 DRAWING #: A000680537

REVISION: B
 DATE: 8/12/20

No. A0000680537 (Part 4 of 4)—INTERCONNECTION XFER SW 100-200A—PWRcell Inverter

GROUP G

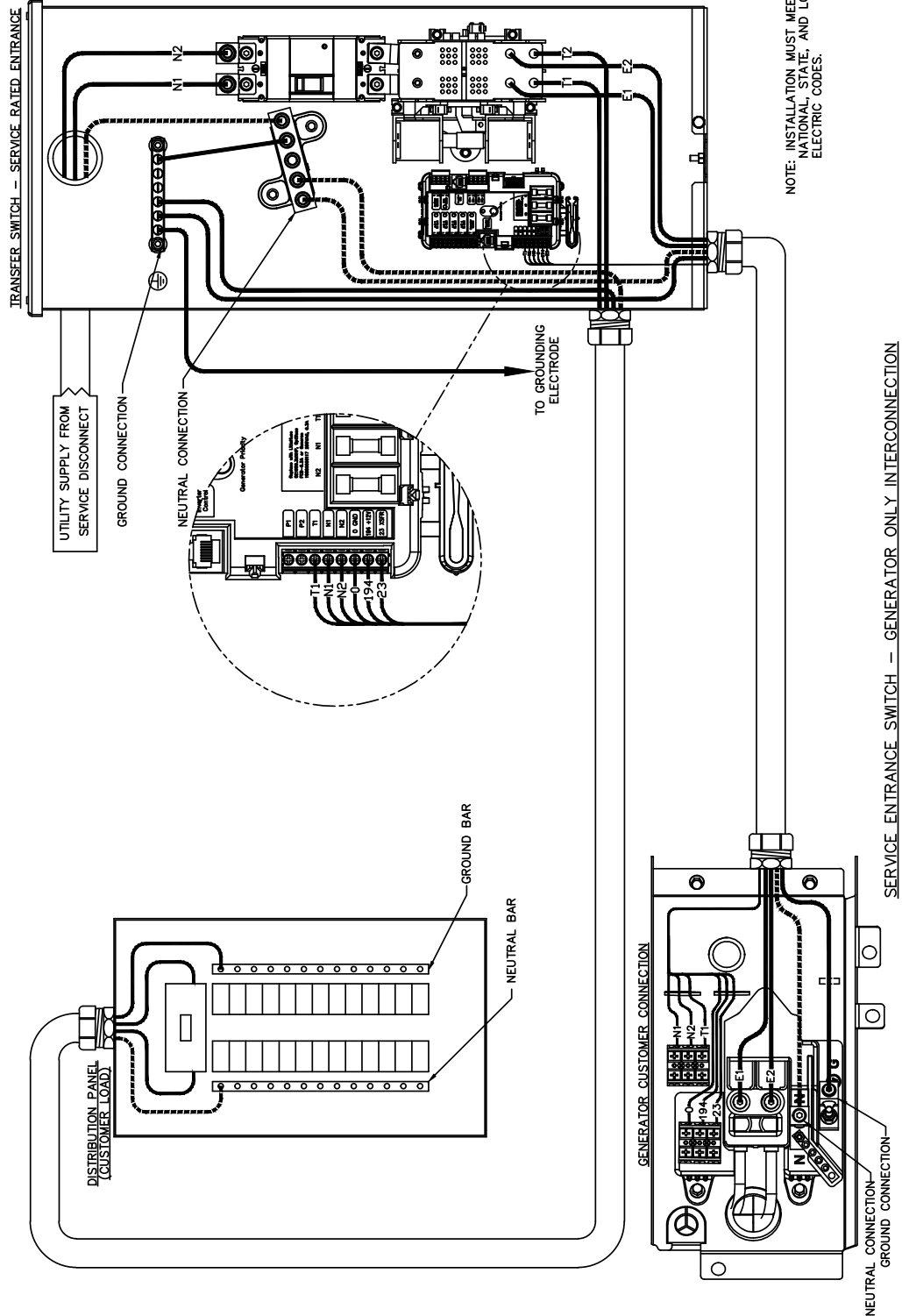

SERVICE ENTRANCE SWITCH — GENERATOR ONLY INTERCONNECTION

WIRING DIAGRAM
 INTERCONNECTION PWRCELL XFER SW 100+200A
 DRAWING #: A0000680537

Page 4 of 4

REVISION: B
 DATE: 8/12/20

This page intentionally left blank.

Part No. A0000647229 Rev. B 08/14/2020

©2020 Generac Power Systems, Inc.

All rights reserved.

Specifications are subject to change without notice.

No reproduction allowed in any form without prior written consent
from Generac Power Systems, Inc.

GENERAC®

Generac Power Systems, Inc.
S45 W29290 Hwy. 59
Waukesha, WI 53189
1-888-GENERAC (1-888-436-3722)
www.generac.com