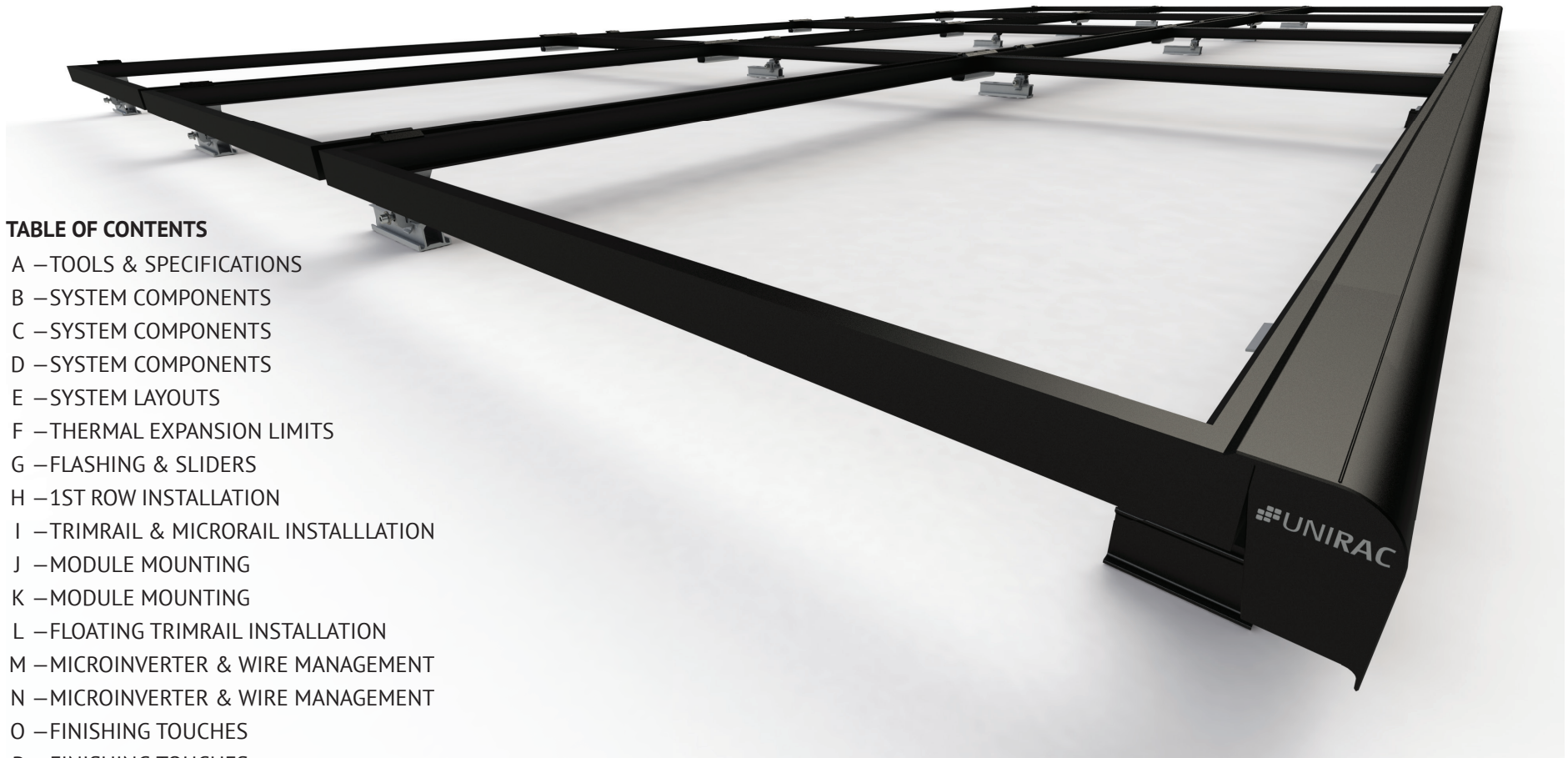

TABLE OF CONTENTS

- A – TOOLS & SPECIFICATIONS
- B – SYSTEM COMPONENTS
- C – SYSTEM COMPONENTS
- D – SYSTEM COMPONENTS
- E – SYSTEM LAYOUTS
- F – THERMAL EXPANSION LIMITS
- G – FLASHING & SLIDERS
- H – 1ST ROW INSTALLATION
- I – TRIMRAIL & MICRORAIL INSTALLATION
- J – MODULE MOUNTING
- K – MODULE MOUNTING
- L – FLOATING TRIMRAIL INSTALLATION
- M – MICROINVERTER & WIRE MANAGEMENT
- N – MICROINVERTER & WIRE MANAGEMENT
- O – FINISHING TOUCHES
- P – FINISHING TOUCHES
- Q – SYSTEM BONDING & GROUNDING
- R – UL CODE COMPLIANCE NOTES
- S – TESTED/CERTIFIED MODULE LIST
- T – MODULE MAINTENANCE
- U – CONSIDERATIONS & MAINTENANCE





TECHNICAL SPECIFICATIONS:

Material Types

All extruded components:
6005A-T61 or 6061-T6 Aluminum

Hardware: Stainless Steel

Bonding and Grounding: Integrated in Microrail™ (Trimrail™ and row to row bonding require additional components)

TOOLS REQUIRED OR RECOMMENDED FOR LAYOUT, FLASHINGS & ROOF ATTACHMENTS:

- Hammer
- Marker / crayon
- Measuring tape
- Drill
- Pilot drill bit
- Pry bar
- String line

TOOLS FOR MODULE INSTALL:

- Drill and socket adapter or socket wrench
- 1/4" hex driver
- Torque wrench
- 1/2" socket (optional)

SAFETY:

All applicable OSHA safety guidelines should be observed when working on a PV installation job site. The installation and handling of PV solar modules, electrical installation and PV racking systems involves handling components with potentially sharp metal edges. Rules regarding the use of gloves and other personal protective equipment should be observed.

TORQUE SPECIFICATIONS:	
All SFM Hardware	20 ft-lbs (unless otherwise noted)
Grounding lugs	Per Page "Q"

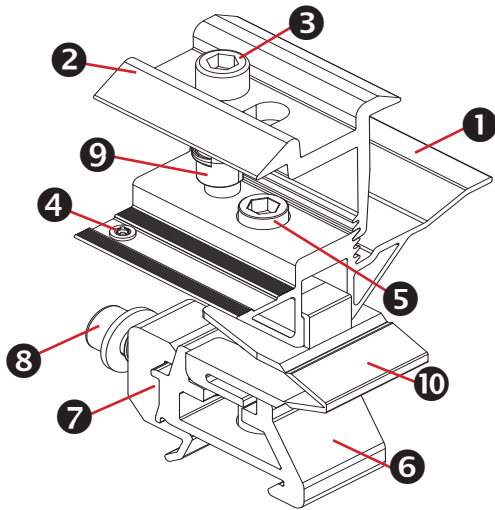

SUNFRAME Microrail™ - 2"

Sub-Components:

1. Base
2. Cap
3. Clamp Socket Head Cap Screw
4. Bonding Pin
5. Height Adjustment Feature
6. Tower
7. Dovetail Lock
8. Dovetail Socket Head Cap Screw
9. Spring Clip
10. Anti-rotation Clip

Functions:

- 1 or 2 module support to roof attachment

Features:

- Arrives on-site pre-assembled and ready for installation
- Cap indicates module height compatibility
 - Supports discrete module thicknesses from 32mm to 46mm
- Receiving feature that allows simple module placement, tightening of fasteners and eliminates working over modules.

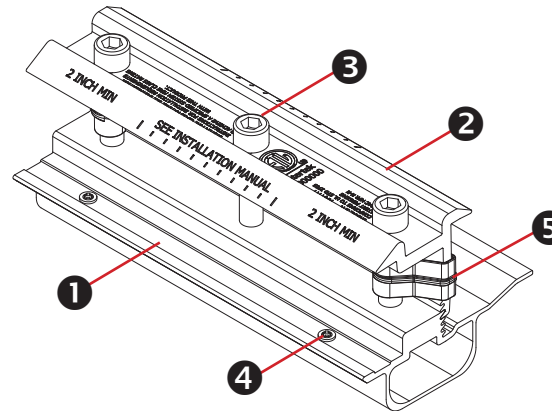

SUNFRAME Microrail™ 6.5" Splice

Sub-Components:

1. Base
2. Cap
3. (3) Clamping Socket Head Cap Screws
4. Bonding Pins
5. (2) Spring Clips

Functions:

- 2,3 or 4 module support & connection
- E-W module to module bonding

Features:

- Arrives on-site pre-assembled and ready for installation
- Cap indicates module height compatibility
 - Supports discrete module thickness from 32mm to 46mm
- Receiving feature that allows simple module placement, tightening of fasteners and eliminates working over modules.
- Does not rattach to roof

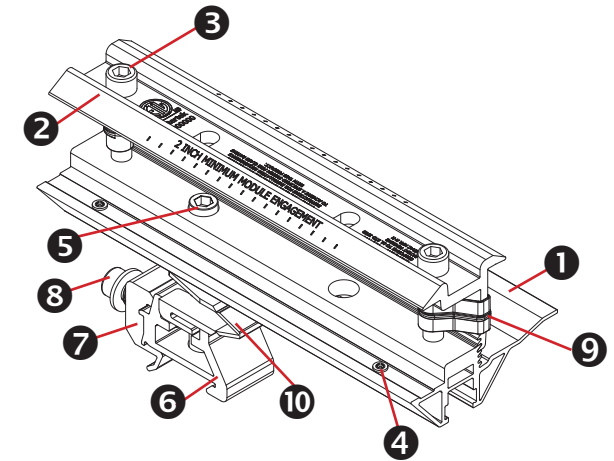

SUNFRAME Microrail™ 8" Attached Splice

Sub-Components:

1. Base
2. Cap
3. (2) Clamp Socket Head Cap Screws
4. (2) Bonding Pins
5. Height Adjustment Feature
6. Tower
7. Dovetail Lock
8. Dovetail Socket Head Cap Screw
9. (2) Spring Clip
10. Anti-Rotation Clip

Functions:

- 2, 3, or 4 module support to roof attachment (when attachment is necessary at splice point)
- E-W module to module bonding

Features:

- Arrives on-site pre-assembled and ready for installation
- Cap indicates module height compatibility
 - Supports discrete module thickness from 32mm to 46mm
- Receiving feature that allows simple module placement, tightening of fasteners and eliminates working over modules.

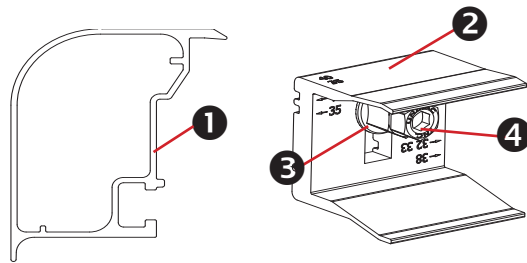

Trimrail™ and Module Clips

Sub-Components:

1. Trim Rail
2. Module Clip
3. T-Bolt
4. Tri-Drive Nut

Trimrail™

Functions:

- Required front row structural support (with module clips)
- Module mounting
- Installation aid
- Aesthetic trim

Features:

- Mounts directly to L-feet
- Aligns and captures module leading edge
 - Supports discrete module thicknesses from 32, 33, 35, 38, and 40mm

Module Clips

Functions:

- Required front row structural support (with trimrail)
- Module mounting

Features:

- Mounts to Trimrail™ with T-bolt and tri-drive nut
- Manually adjustable to fit module thicknesses 32, 33, 35, 38, and 40mm.

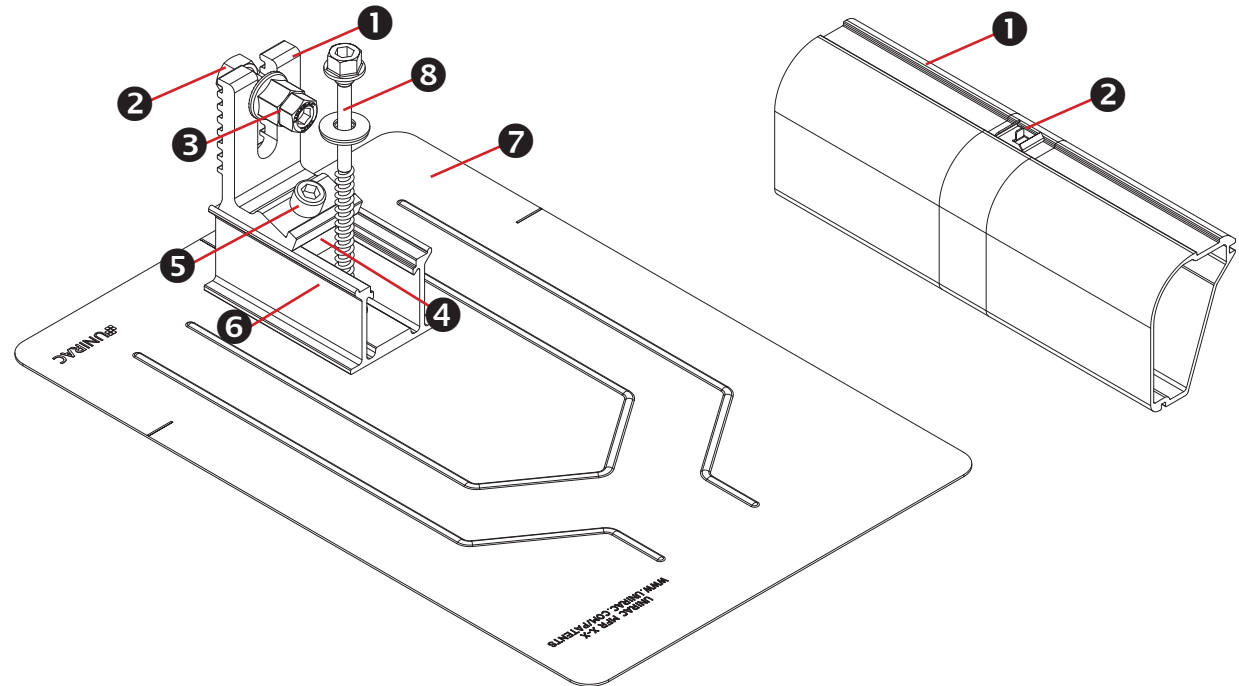

Trimrail™ Flashkit

Sub-Components:

1. L-Foot
2. Hex bolt
3. Tri-drive nut
4. Channel Nut
5. Socket Head Cap Screw
6. 3" Channel/Slider w/grommet
7. Flashing
8. Structural Screw & SS EPDM Washer

Functions:

- Attach Trimrail™ to roof attachment / flashing
- Patented roof sealing technology at roof attachment point

Features:

- Slot provides vertical adjustments to level array
- Slider provides north/south adjustment along the slope of the roof
- Shed and Seal Technology

Trimrail™ Splice

Sub-Components:

1. Structural Splice Extrusion
2. Bonding Clip

Functions:

- Front row structural support
- Installation aid
- Structurally connects 2 pieces of Trimrail™
- Electrically bonds 2 pieces of Trimrail™

Features:

- Aligns and connects Trimrail™ pieces
- Tool-less installation

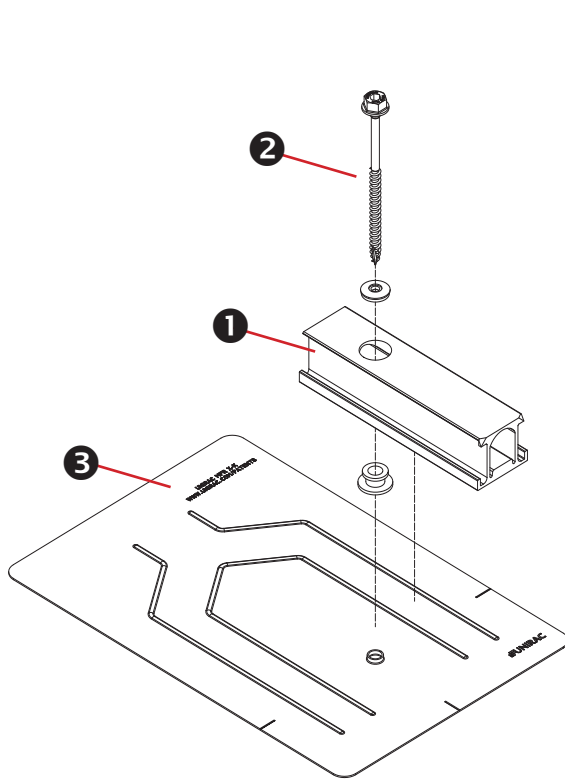

SFM Slider Flashkit

Sub-Components:

1. Slider w/grommet
2. Structural Screw & SS EPDM washer
3. Flashing

Functions:

- Patented Shed & Seal roof sealing technology at roof attachment point
- For use with compatible 2" Microrail or 8" Attached Splices

Features:

- Slider provides north/south adjustment along the slope of the roof
- Shed and Seal Technology

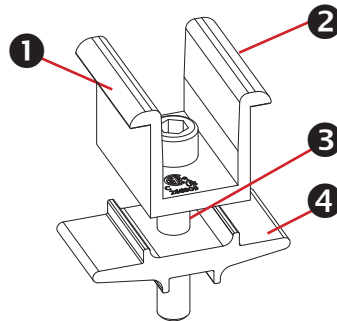

Module-to-Module N-S Bonding

Sub-Components:

1. Clamp
2. Bonding Pins (2)
3. 5/16" Socket Head Cap Screw
4. Clamp Base

Functions/ Features:

- Row to row bonding
- Single Use Only
- Fits module sizes 32-40mm

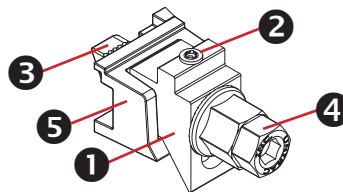

Trim -to- Module Bonding Clamp and Floating Trim Clamp

Sub-Components:

1. Wedge
2. Bonding Pin
3. T-Bolt
4. Nut
5. Cast Base

Functions/ Features:

- Module to Trimrail™ bonding - single use only
- Attaches Trimrail™ to module when fewer than 2 rafter attachment points are available
- Fits module sizes 32-40mm
- Fits module sizes 32-40mm

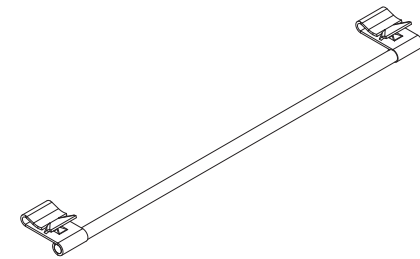

Wire Bonding Clip w/ 8AWG

Functions:

- Row to row bonding
- Module to Trimrail™ bonding
- Single Use Only

Features:

Tool-less installation

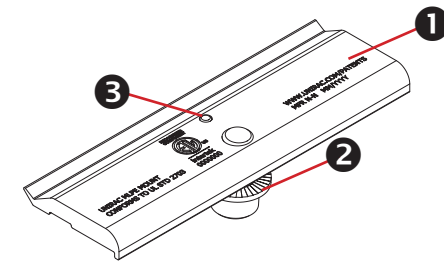

MLPE Mounting Assembly

Sub-Components:

1. MLPE Mount Base
2. 5/16 Socket Head Cap Screw
3. Bonding Pin

Functions:

- Securely mounts MLPE to module frames
- MLPE to module bonding

Features:

- Mounts easily to typical module flange
- UL2703 Recognized

MLPE = Module Level Power Electronics, e.g. microinverter or power optimizer

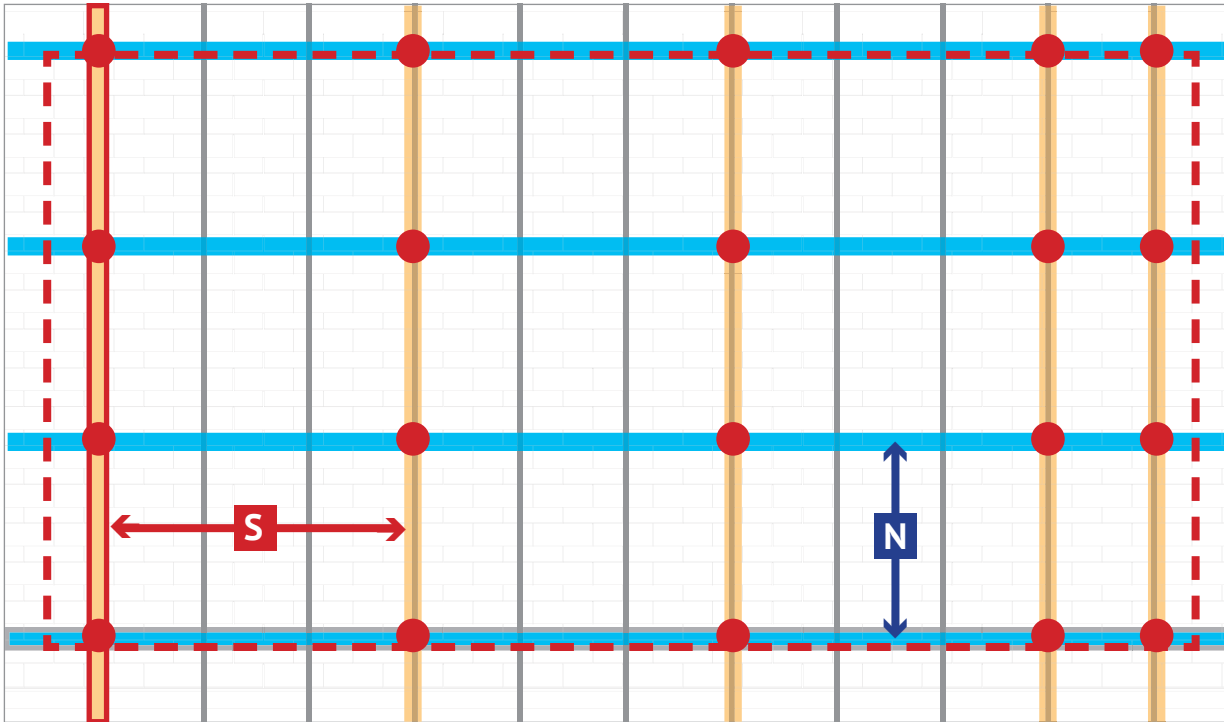

1. Determine appropriate array location on roof. **NOTE: Consult local AHJ regarding setback requirements**
2. Select starting course of shingles (or tiles)
3. Mark next row of attachments and repeat for remaining rows
- N** - NS distance equals module width +1"
4. Locate 1st rafter closest to array edge (and inside array footprint) and mark
5. Find next rafter for attachment based on appropriate span
 - Continue to end of array
 - Mark last rafter before end of array
- S** Span
6. Mark attachment points on rafters along each NS module grid line
7. Refer to Unirac SFM D&E Guide and U-Builder for allowable spans and cantilevers.

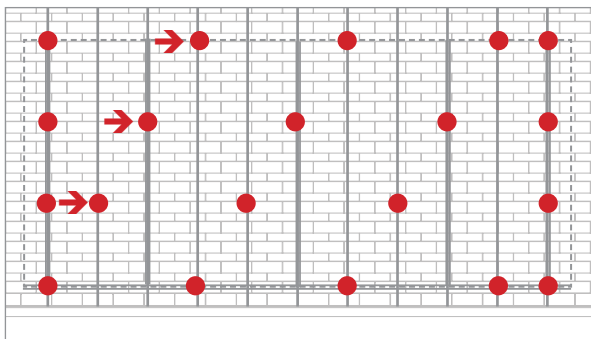

TO STAGGER ATTACHMENTS: Shift each subsequent row of attachments one rafter over.

See the Design and Engineering Guide for details on regional max spans and overhang.

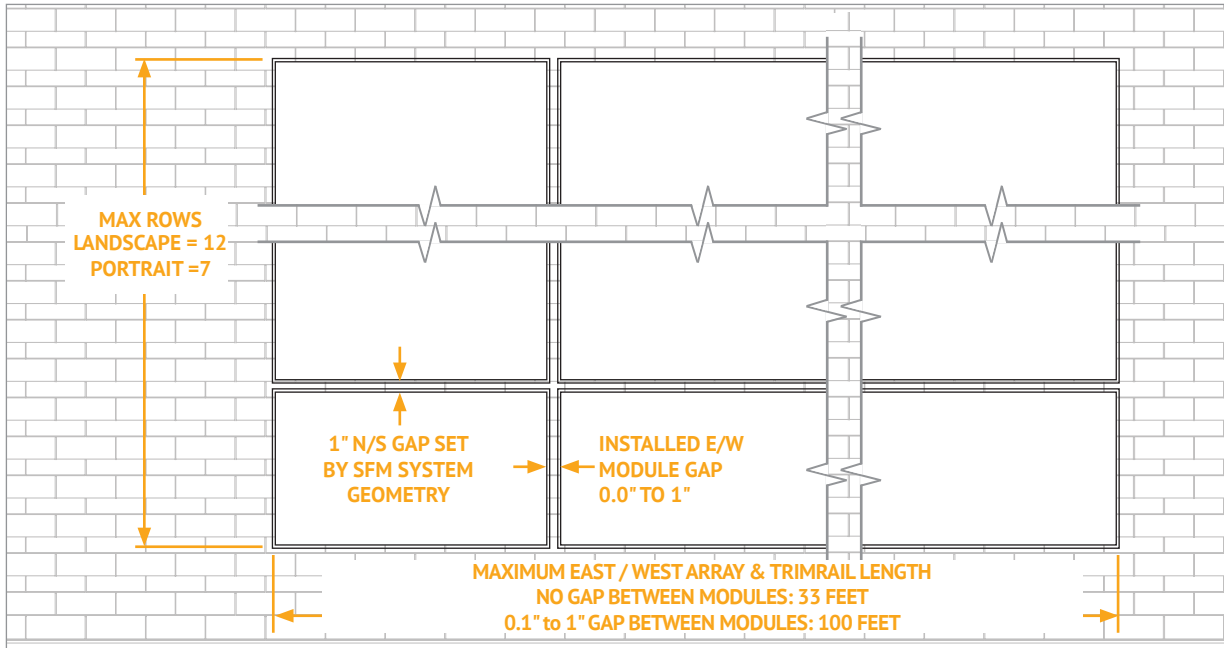

NORTH-SOUTH THERMAL EXPANSION LIMITS:

- 12 Rows of modules - Landscape orientation
- 7 Rows of modules - Portrait Orientation

EAST-WEST THERMAL EXPANSION LIMITS:

- 33ft. with no module gap (butted modules)
- 100ft. with a minimum module gap of 1/8"

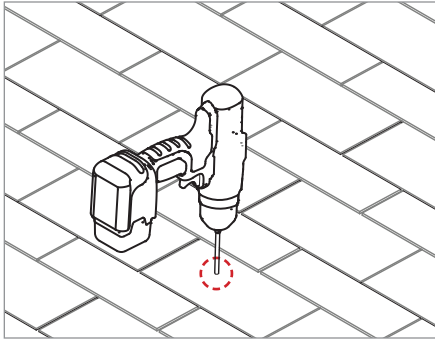

PILOT HOLES:

Drill pilot holes for lag screws or structural screws (as necessary) at marked attachment points

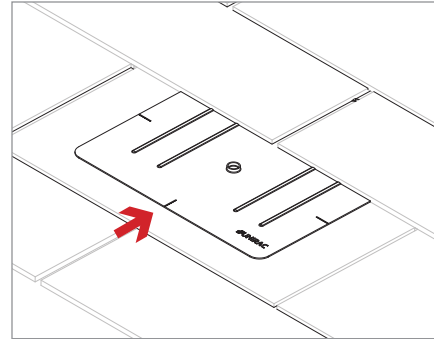

FLASHINGS:

Place flashings

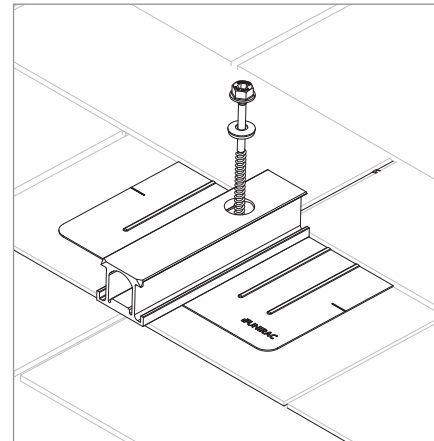
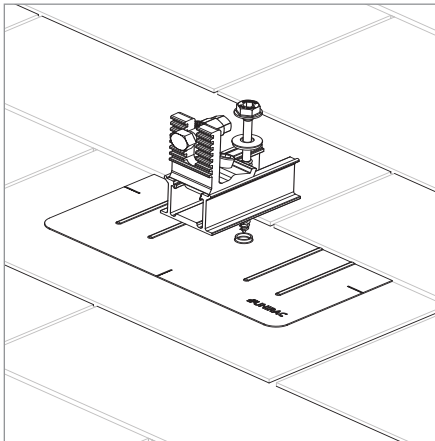

INSTALL SLIDERS AND TRIMRAIL ROOF ATTACHMENTS:

- Insert flashings per manufacturer instructions
 - Attach sliders to rafters
 - Verify proper row to row spacing for module size (Mod NS + 1")
 - Ensure that Trimrail™ roof attachments in each row have sufficient engagement with slider dovetails for proper attachment.
- NOTE: Use Lag screw or structural fastener with a maximum diameter of 5/16"**

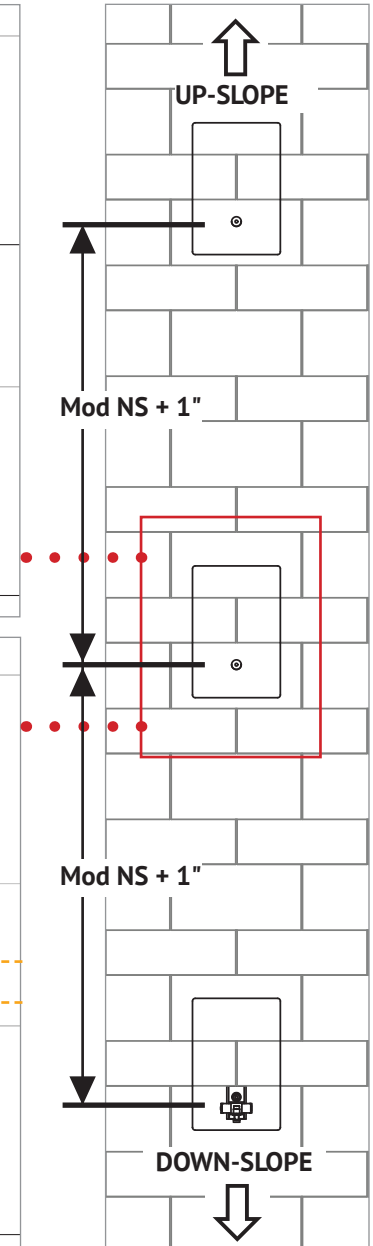
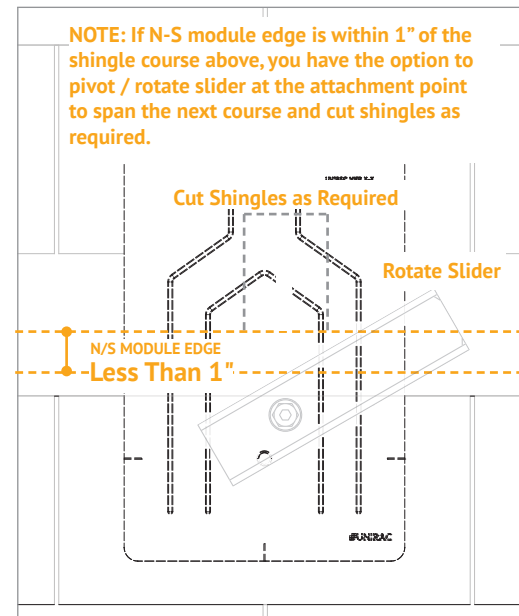
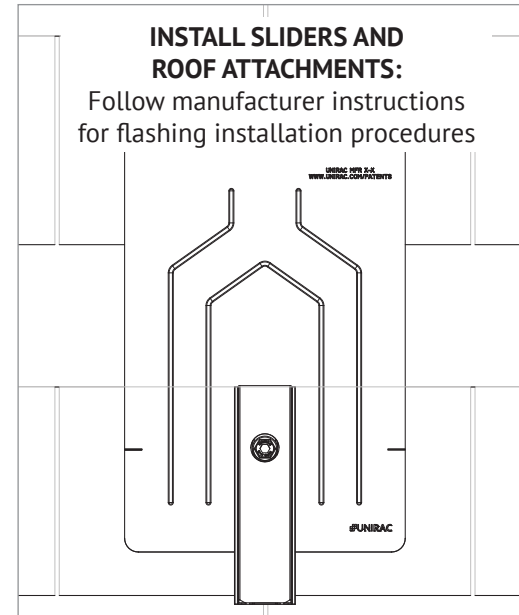

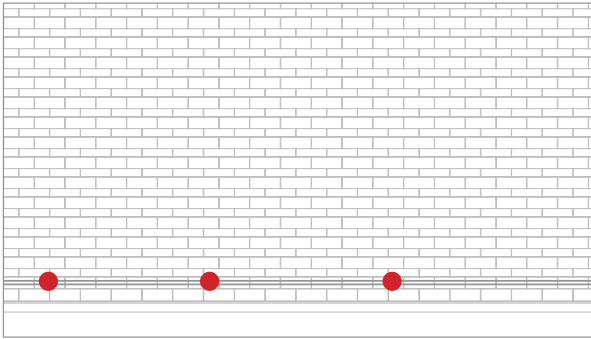

ALIGN FRONT ROW:

Align front row Trimrail™ roof attachments with string line

TIP: Pull String-line across back (smooth) edge of attachments

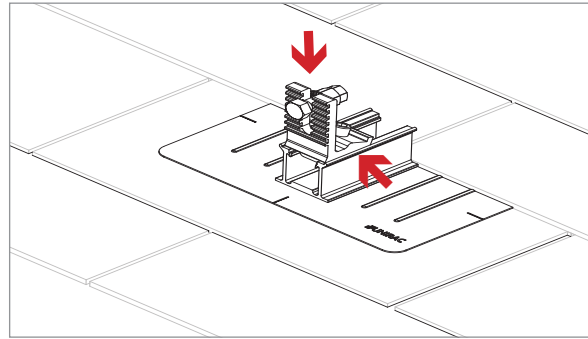

TIGHTEN SLIDER:

Tighten front row lag screw and Trimrail™ roof attachment channel clamp socket head cap screw.

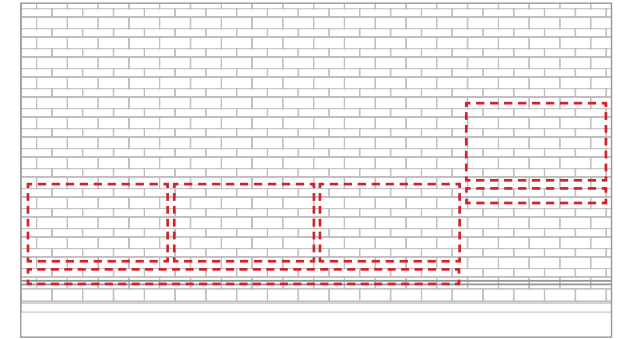

TRIMRAIL PREPARATION:

Determine overall length of Trimrail™ for front row. Determine splice locations (if any) and Trimrail™ lengths required. When 2 or less attachment points are available at front of module edge, a Floating Trim Clamp may be required, see page (L) for details.

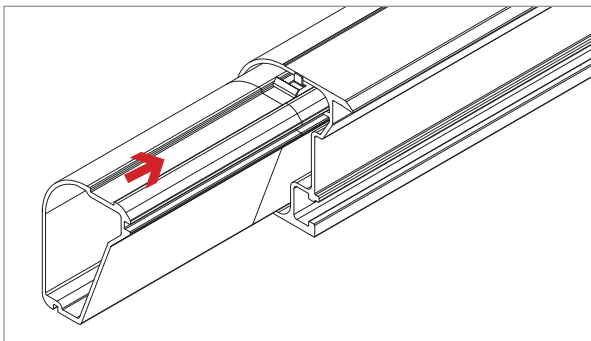

INSTALL TRIMRAIL SPLICE:

Place Trimrail™ with front side up and firmly insert splice into Trimrail™, until it contacts vertical stop tab of steel bonding clip.

NOTE: Do not over-insert splice

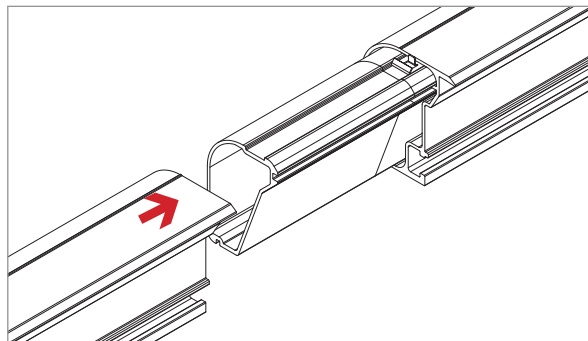

JOIN TRIMRAIL SECTIONS AT SPLICE:

While holding Trimrail™ sections in alignment, join sections together with splice centered at joint and vertical stop tab in contact with both trimrail sections.

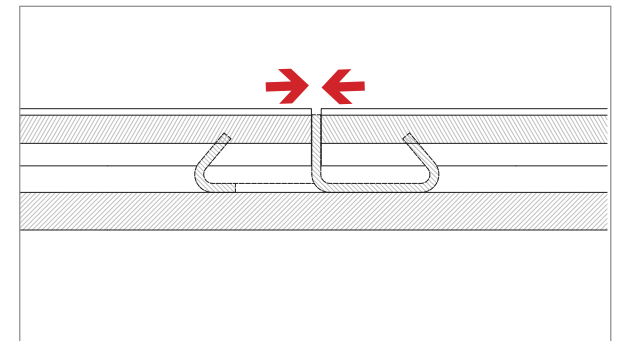

VERIFY SPLICE INSTALLATION:

Verify full engagement of splice clip at top of trim rail. Bonding between trim sections occurs through the splice.

See the Design and Engineering Guide for details on regional max spans and overhang.

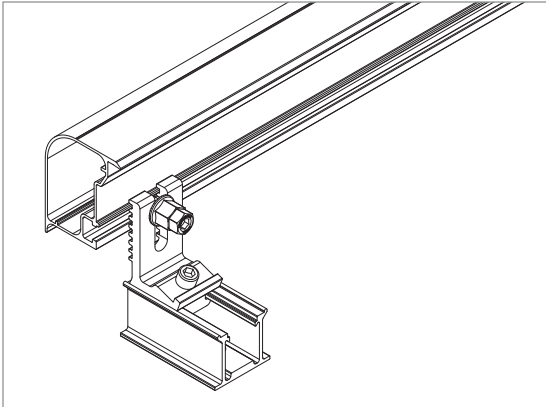

ATTACH TRIMRAIL TO ROOF ATTACHMENT:
Attach rail using 3/8" hex bolt & Tri-drive or serrated flange nuts. Make sure Trimrail™ is level across all Trimrail™ roof attachments. After rail is level, tighten channel clamp bolts to secure Trimrail™ roof attachments to channels.

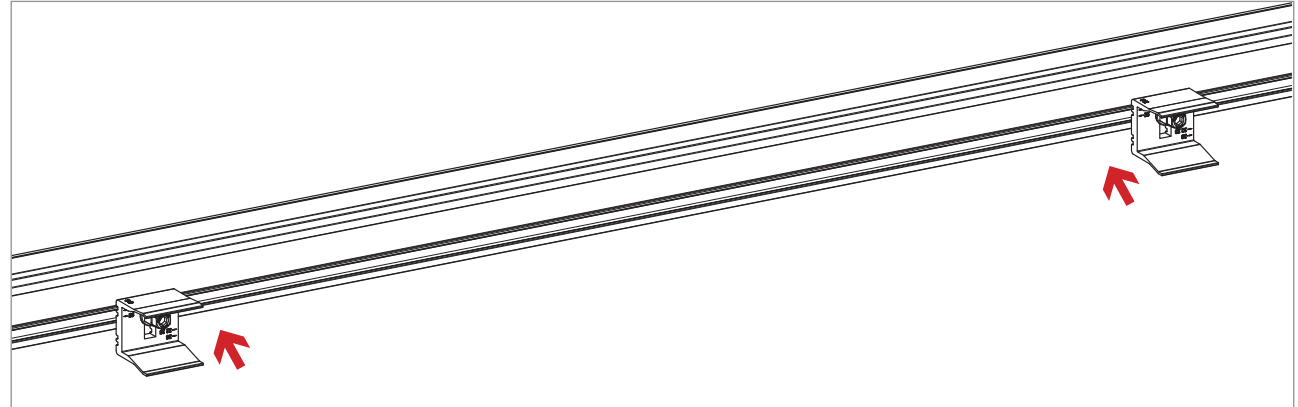

INSTALL MODULE CLIPS ON TRIMRAIL:
Attach module clips to Trimrail using 3/8" T-bolts and Tri-drive or serrated flange nuts. A minimum of two clips are required per module. Refer to SFM D&E guide and U-builder for required position and quantity of module clips.

NOTE: module clips may be pre-installed on trimrail prior to attaching trimrail to roof attachments

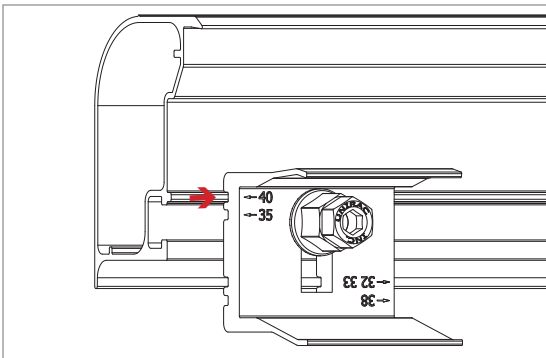

POSITION MODULE CLIPS ACCORDING TO MODULE THICKNESS:
Align notch in module clip with trimrail rib according to module thickness (identified in mm on faces of module clips). Rotate clip to position at required location.

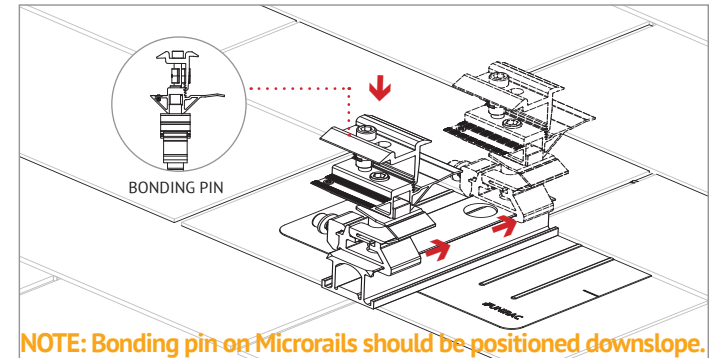
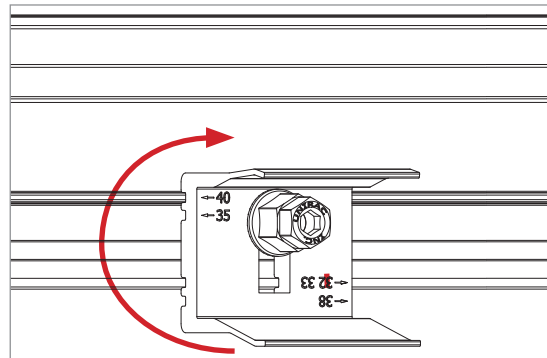

NOTE: Bonding pin on Microrails should be positioned downslope.

INSTALL MICRORAILS:
Install Microrail™ at marked attachment points. Click Microrail™ into sliders and push Microrail™ to top of slider. Ensure that cap remains in upper most (40mm) position.

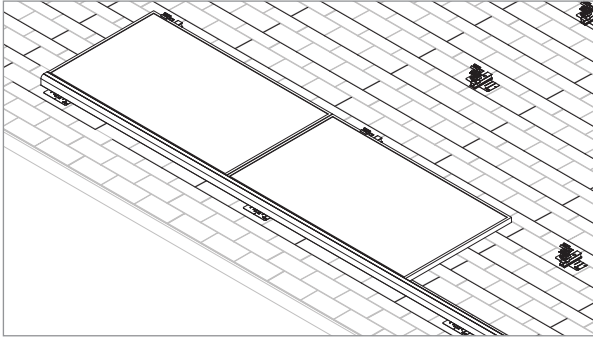

LAY IN MODULE(S):

Install first two (2) modules on bottom row. Install downhill end of module into the Trimrail™ and module clips first and then position uphill 2" microrails to support modules.

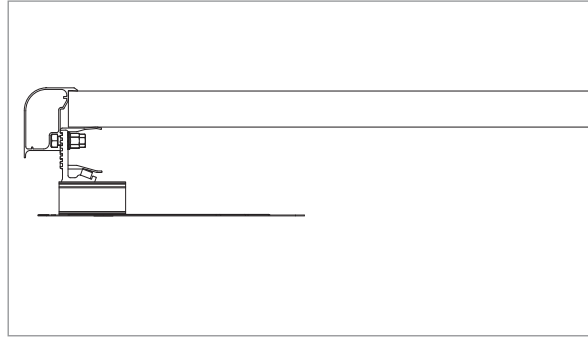

LAY IN MODULE(S):

Module should slide into catch features of the Trimrail™ and module clips.

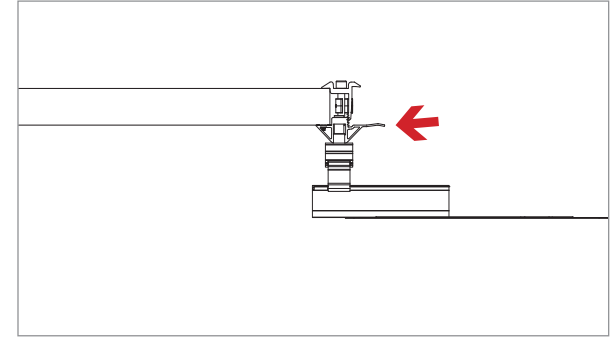

SEAT MODULE(S):

Ensure that modules are properly seated in cap and base.

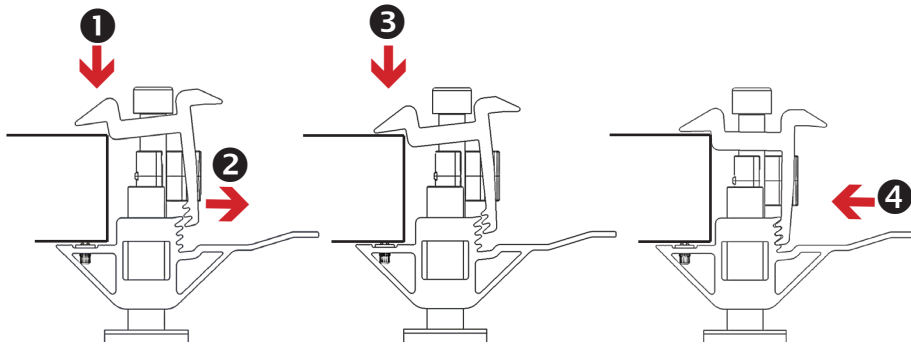

ADJUST MICRORAIL CAP DOWN TO ENGAGE WITH MODULE:

With microrail pressed against module **1.** Apply downward pressure to module side of cap which will **2.** separate cap from base on capture side and allow cap to **3.** contact module and **4.** simultaneously re-engage to base at corresponding module height location.

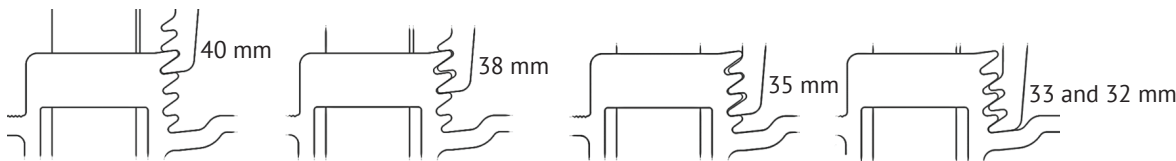

VERIFY CORRECT POSITION OF CAP:

Check position and verify cap on down-slope side is tight with no gap between cap and module after tightening bolt

Wire management is performed after each row of modules is installed. Refer to wire management section (pp. L & M) for detailed instructions.

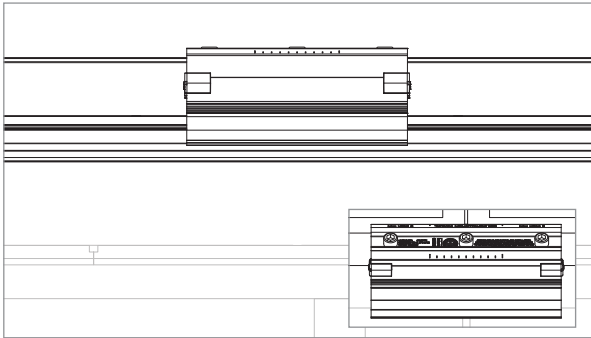

ATTACH SPLICE:

- Attach splice at intersection of two (2) modules.
- Use attached splice if required per SFM D&E Guide.
 - Ensure minimum module engagement using indicator marks.

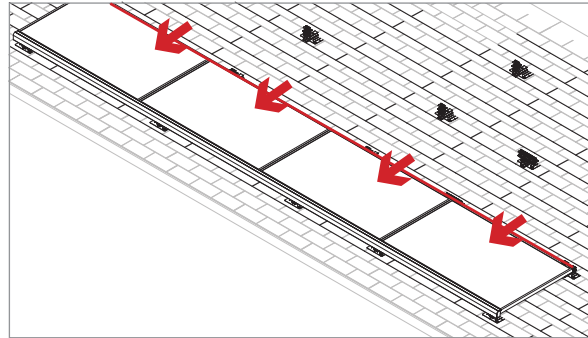

FASTEN MODULES:

Finish installing modules along row and tighten fastening bolts on microrails and splices to 20 ft. lbs after entire row is installed.

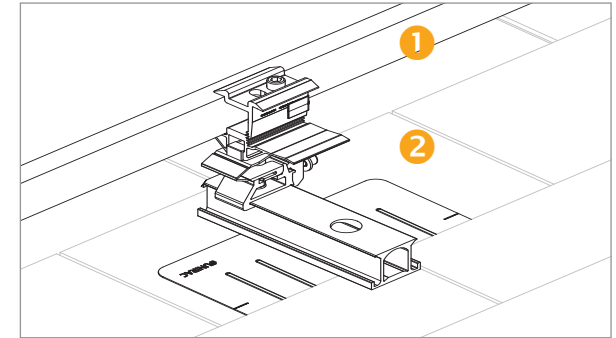

TIGHTEN FASTENERS:

Tighten fasteners to 20 ft lbs.

NOTE: Tighten components in following order:
 ① Module clamp socket head cap screw then
 ② Dovetail socket head cap screw

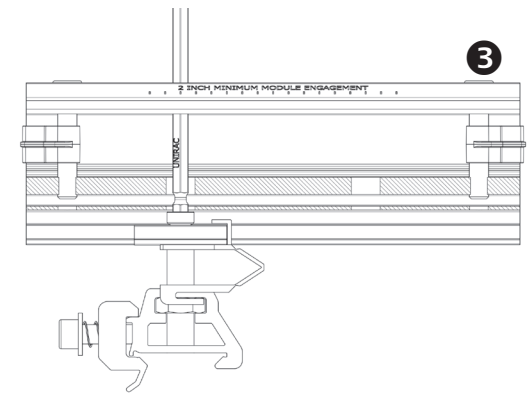
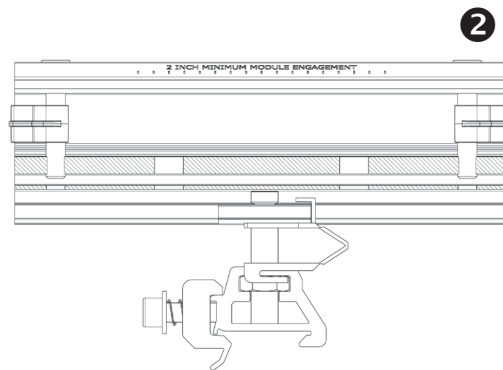
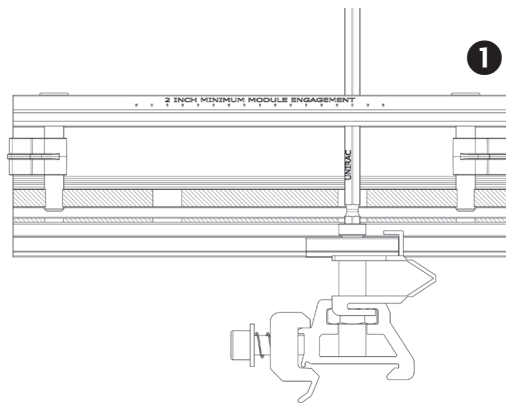

ATTACHED SPLICE ADJUSTMENT:

Tower and height adjustment feature may be located to alternate position as required to achieve minimum module engagement.

1. With 1/4" hex drive tool, rotate height adjustment feature clockwise until head clears thru-hole in base. 2. slide tower to alternate position and align.

height adjustment feature head with clearance hole. 3. Rotate height adjustment feature counter-clockwise until head enters clearance hole.

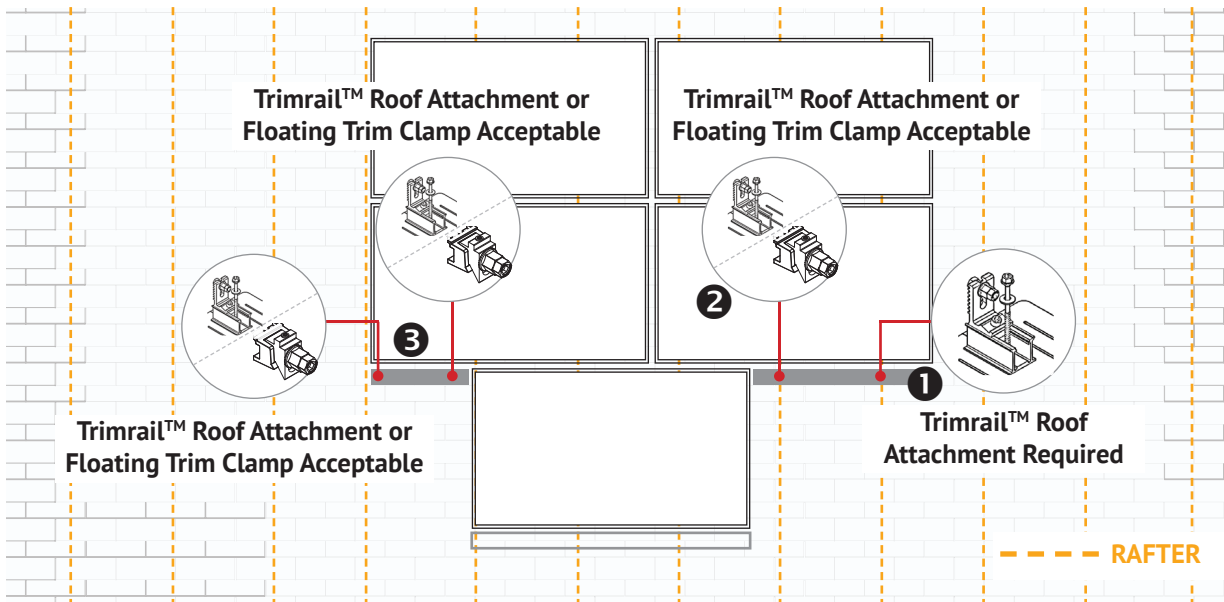
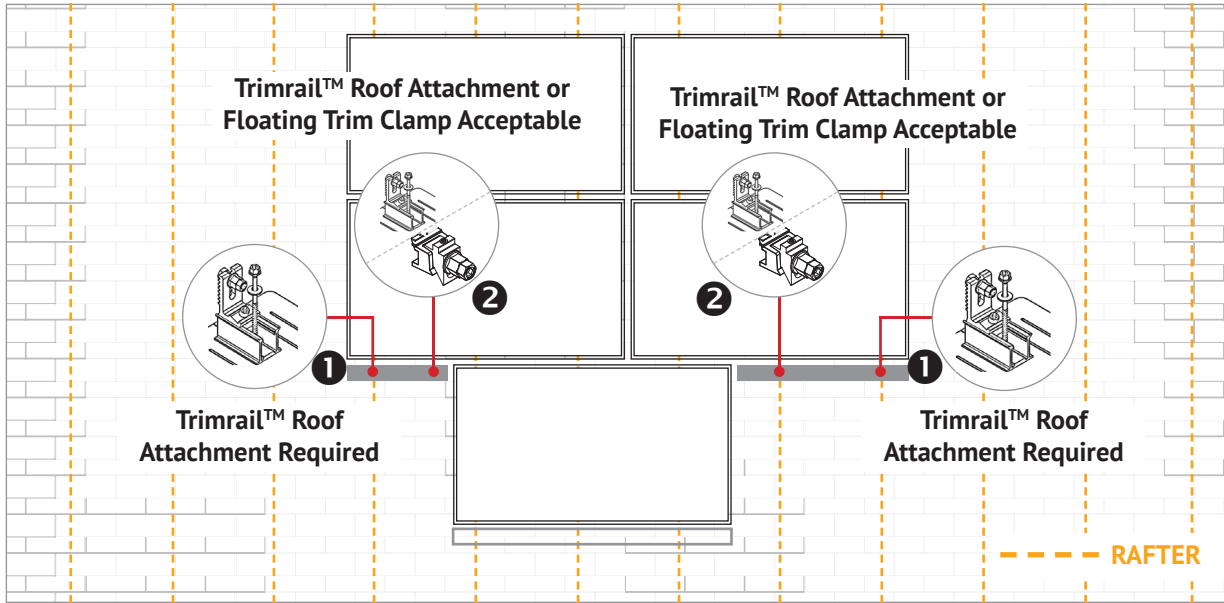

REQUIREMENTS FOR TRIMRAIL™ ROOF ATTACHMENTS & FLOATING TRIM CLAMP:

1. Trimrail™ Flashkit Roof Attachments shall be used at rafters nearest to and under outside edges of array (unless noted per item 3).
2. Use Floating Trim Clamp or Trimrail™ Flashkit Roof Attachment attached to deck without rafter support on the longest "free" side if only one (1) Trimrail™ Roof Attachment is utilized.
3. Use of 2 Floating Trim Clamps or 2 Trimrail™ Flashkit Roof Attachments attached to deck without rafter support is acceptable if the section of Trimrail™ being mounted is less than 24"

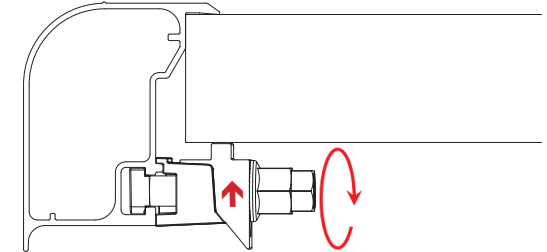

SECURING TRIMRAIL™ WITH FLOATING TRIM CLAMPS:

Installation of floating trim sections may occur before module is secured. Floating Trim Clamp captures module flange when nut is tightened to 20 ft-lbs as shown above.

NOTE: THE FLOATING TRIM CLIP WILL PROVIDE AN ELECTRICAL BOND BETWEEN THE MODULE AND THE TRIM RAIL. IF AT LEAST ONE FLOATING TRIM CLIP IS NOT ATTACHED TO A RAIL SECTION, A WIRE BONDING CLIP OR OTHER APPROVED BONDING DEVICE MUST BE INSTALLED.

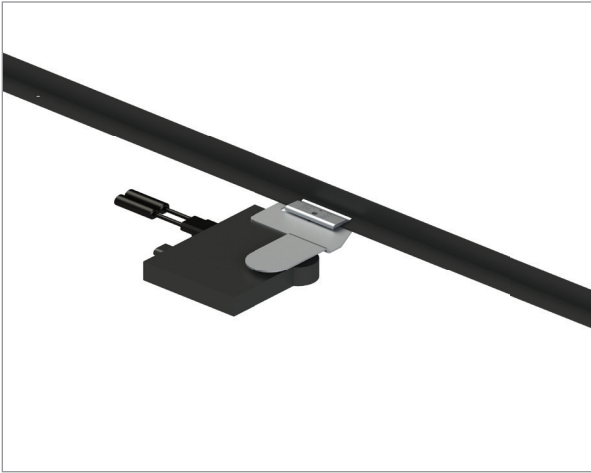

PRE-INSTALL MLPE:

Install MLPE in a location on the module that will not interfere with microrails or grounding lugs. To use trunk cable most efficiently, install MLPE components in the same locations on all modules in the same row.

TORQUE VALUE: 20FT-LBS

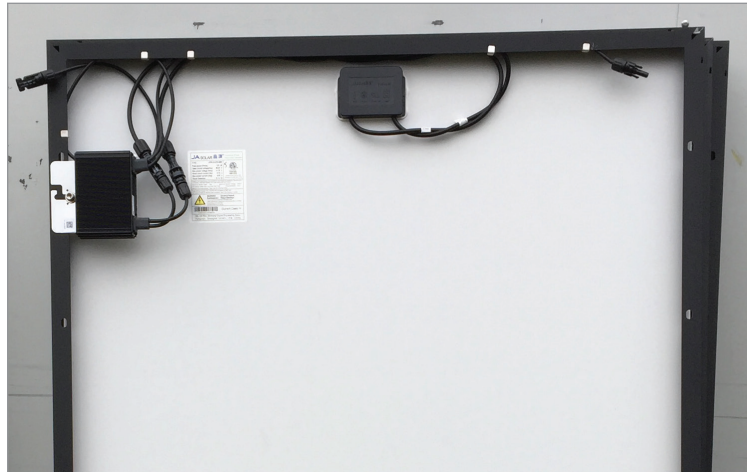
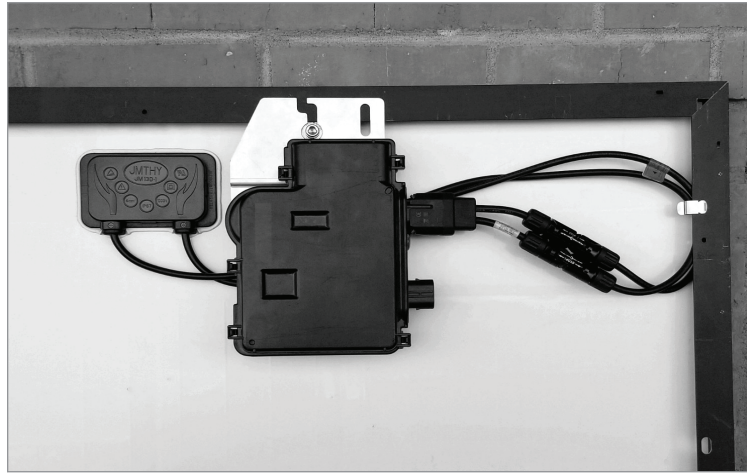

MLPE MOUNTING LOCATION & WIRE MANAGEMENT:

Install the MLPE Mount on the short side of the module when mounting in landscape orientation. Install MLPE Mount on the long side of module when mounting in portrait orientation.

ABOVE IMAGE: MLPE mount w/ microinverter & wire management

BELOW IMAGE: MLPE mount w/ power optimizer & wire mgnt.

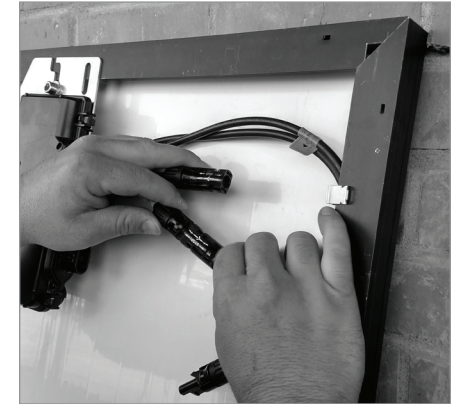

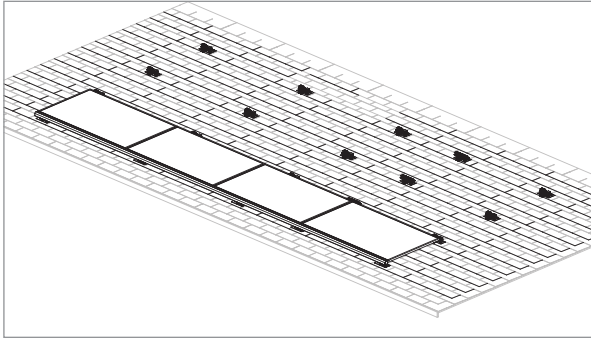

MICROINVERTER:

Before installing a row of modules place microinverter trunk cable.

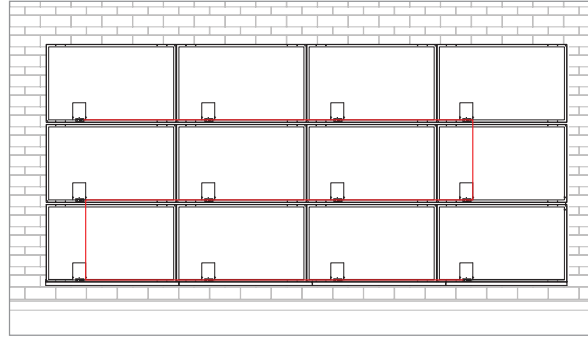

WIRE MANAGEMENT:

Verify wire management is complete after each row is installed.

EXAMPLES:

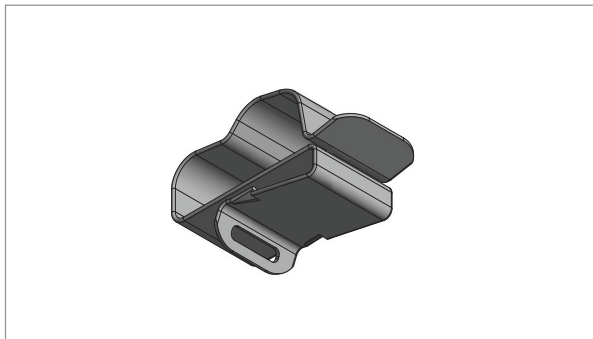

MICROINVERTER TRUNK CABLE:

The trunk cable can be managed securely by using stainless steel wire management clips attached to the module frame.

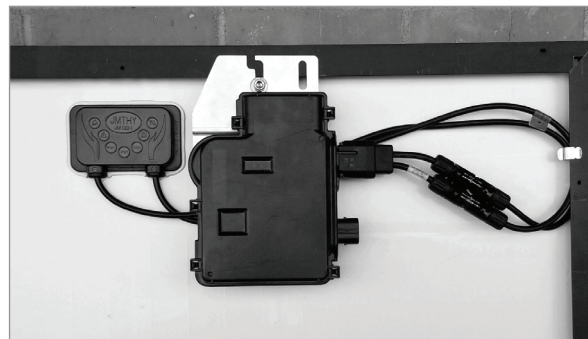

TIPS & TRICKS:

Twisting the PV module wires and/or tying a loose knot can also help manage these wires.

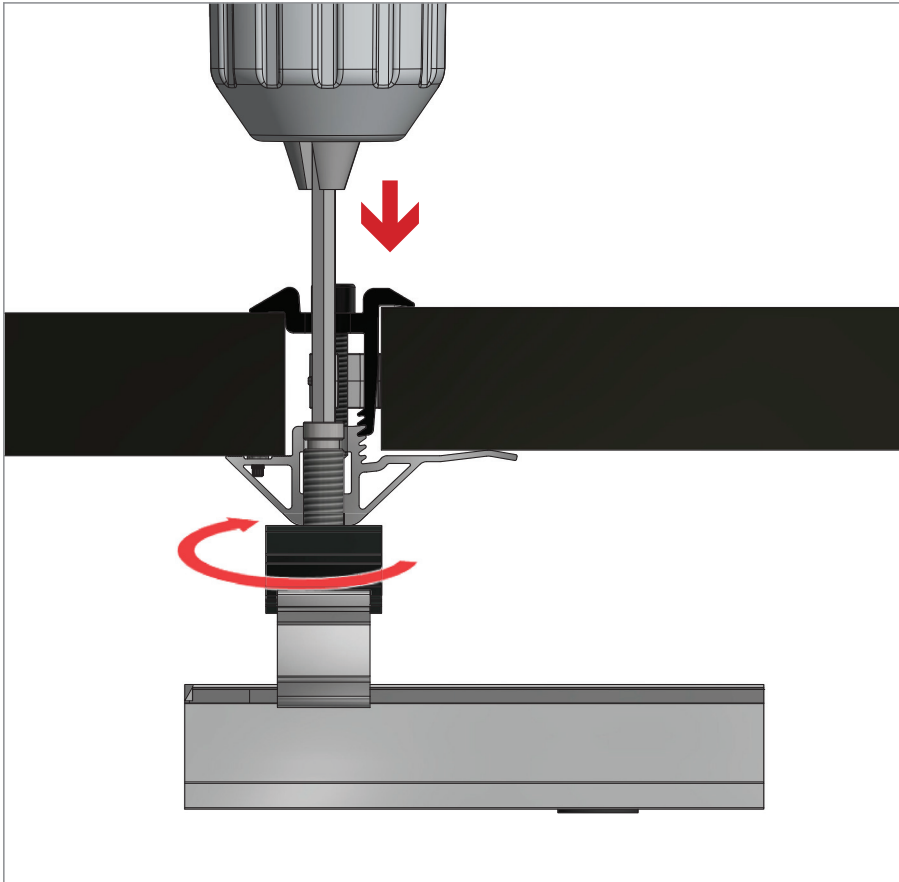

POST INSTALL HEIGHT ADJUSTMENT:

Height adjustment of each attached Microrail™ assembly can be performed by rotating the height adjustment feature with a ¼" hex drive tool. Clockwise rotation will adjust the Microrail™ upward. Counter clockwise rotation will adjust the Microrail™ downward. Insert hex drive tool through holes in caps to access the height adjustment feature.

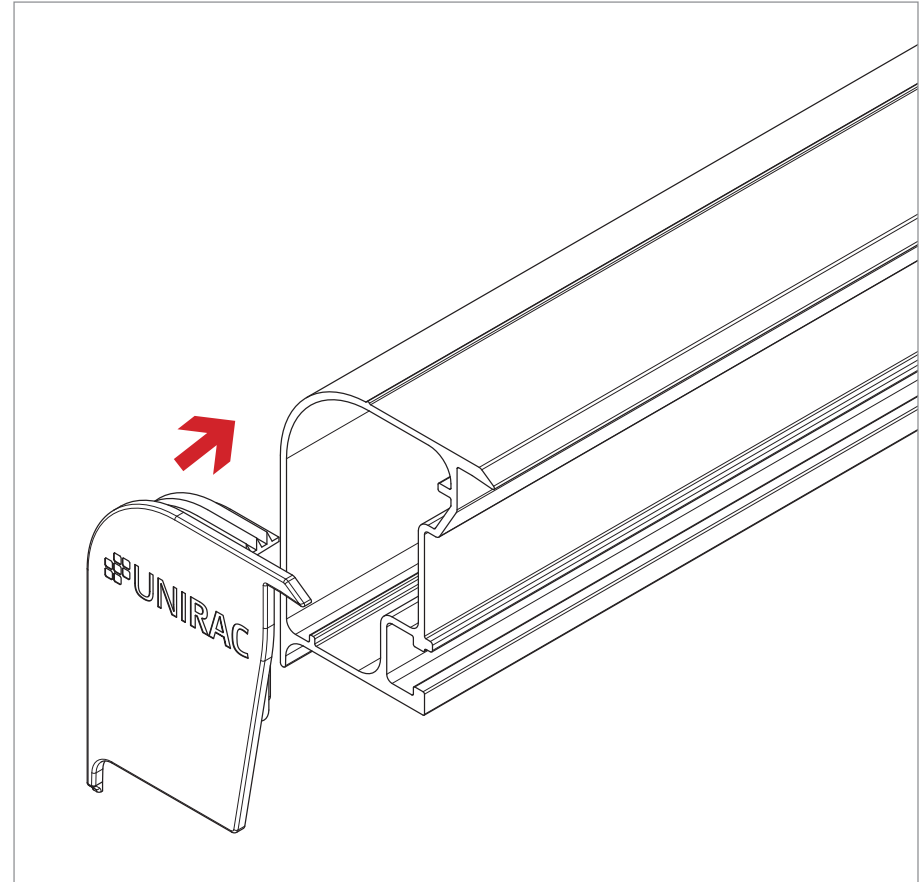

INSTALL END CAPS:

Install end caps at ends of exposed trimrail sections. Align end cap with trimrail and apply pressure until fully seated.

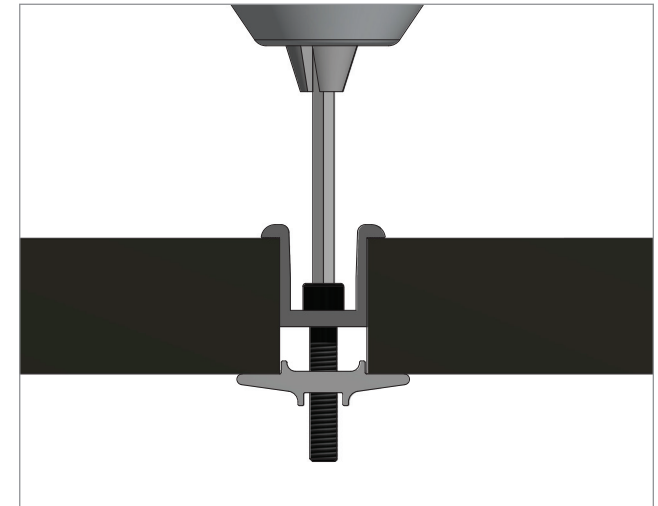
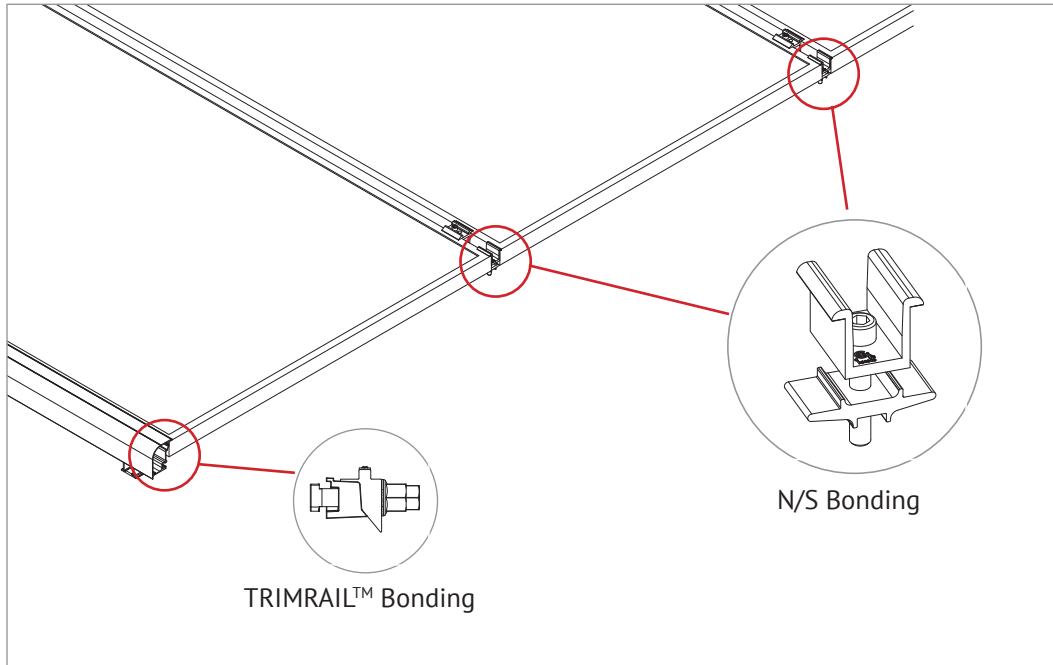

N/S Bonding Clamp:
Insert clamp between modules.
Torque to 20 ft.-lbs.

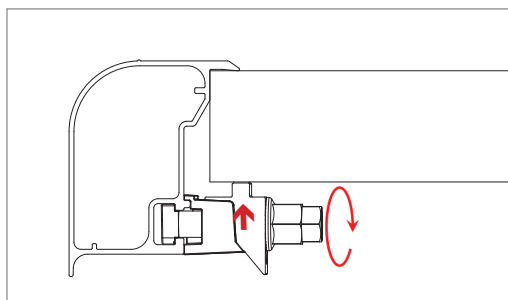

TRIMRAIL™ Bonding:
Insert clamp and Tbolt into trimrail slot.
Tighten tri-drive nut until bonding pin
contacts module.
Torque to 20 ft. lbs.

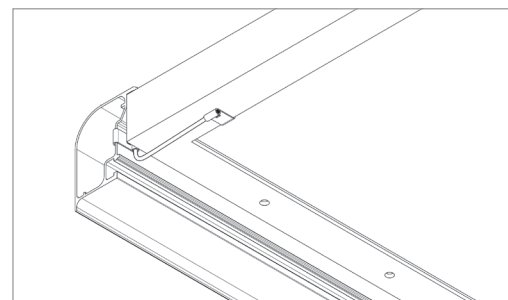

Trimrail Bonding Alternate Method:
Attach a bonding clip from the Trimrail™
to an adjacent module. Fully seat bonding
clip until radius portion is in contact with
Trimrail™ mating surface and module flange.

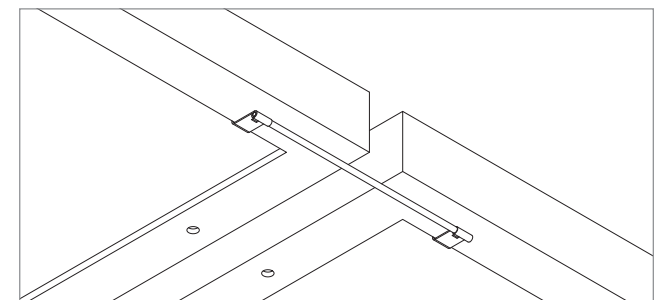

N/S Bonding Alternate Method:
Fully seat bonding clip on each module
flange to provide bond across N/S
module gap.

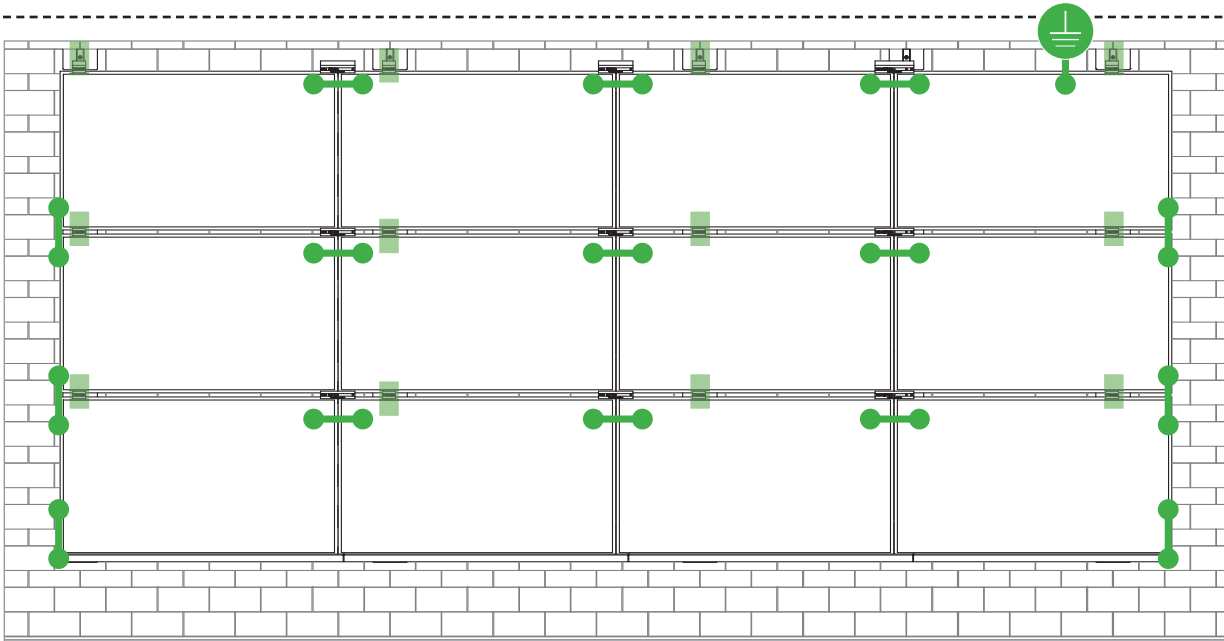

Star Washer is Single Use Only

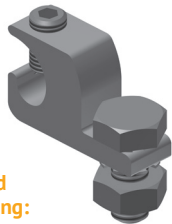

TERMINAL TORQUE,
Install Conductor and torque to the following:
4-6 AWG: 35in-lbs
8 AWG: 25 in-lbs
10-14 AWG: 20 in-lbs

TERMINAL TORQUE,
Install Conductor and torque to the following:
4-14 AWG: 35in-lbs

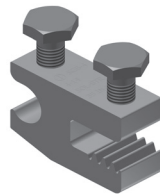

WEEBLUG Single Use Only

TERMINAL TORQUE,
Install Conductor and torque to the following:
6-14 AWG: 7ft-lbs

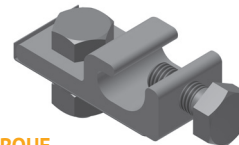

LUG DETAIL & TORQUE INFO IlSCO Lay-In Lug (GBL-4DBT)

- 10-32 mounting hardware
- Torque = 5 ft-lb
- AWG 4-14 - Solid or Stranded

LUG DETAIL & TORQUE INFO IlSCO Flange Lug (SGB-4)

- 1/4" mounting hardware
- Torque = 75 in-lb
- AWG 4-14 - Solid or Stranded

LUG DETAIL & TORQUE INFO Wiley WEEBLUG (6.7)

- 1/4" mounting hardware
- Torque = 10 ft-lb
- AWG 6-14 - Solid or Stranded

NOTE: ISOLATE COPPER FROM ALUMINUM CONTACT TO PREVENT CORROSION

System bonding is accomplished through modules. System grounding accomplished by attaching a ground lug to any module at a location on the module specified by the module manufacturer.

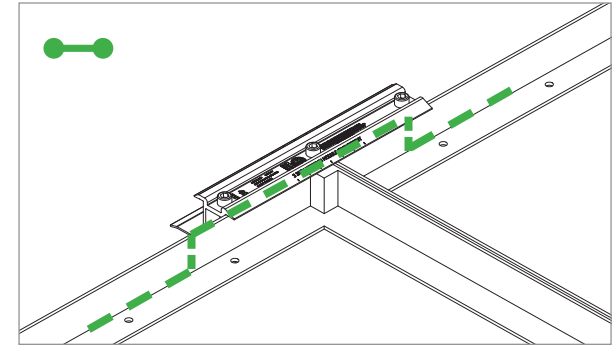

E-W BONDING PATH:

E-W module to module bonding is accomplished with 2 pre-installed bonding pins which engage on the secure side of the Microrail™ and splice.

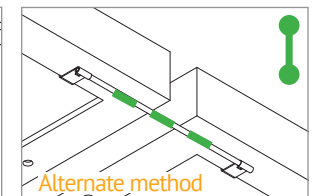
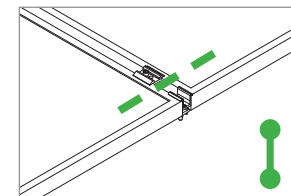

N-S BONDING PATH:

N-S module to module bonding is accomplished with bonding clamp with 2 integral bonding pins. (refer also to alternate method)

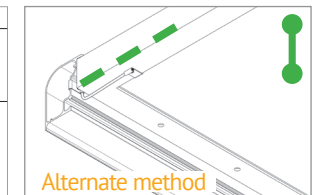
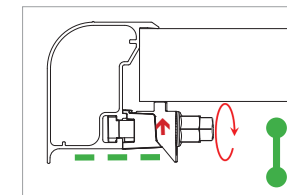

TRIMRAIL BONDING PATH:

Trimrail to module bonding is accomplished with bonding clamp with integral bonding pin and bonding T-bolt. (refer also to alternate method)

SYSTEM LEVEL FIRE CLASSIFICATION

The system fire class rating requires installation in the manner specified in the SUNFRAME MICRORAIL (SFM) Installation Guide. SFM has been classified to the system level fire portion of UL 1703. This UL 1703 classification has been incorporated into the UL 2703 product certification. SFM has achieved Class A, B & C system level performance for low slope & steep sloped roofs when used in conjunction with type 1 and type 2 modules. Class A, B & C system level fire

performance is inherent in the SFM design, and no additional mitigation measures are required. The fire classification rating is valid for any roof pitch. There is no required minimum or maximum height limitation above the roof deck to maintain the Class A, B & C fire rating for SFM. SUNFRAME MICRORAIL™ components shall be mounted over a fire resistant roof covering rated for the application.

Module Type	Roof Slope	System Level Fire Rating	Microrail Direction	Module Orientation	Mitigation Required
Type 1 and Type 2	Steep Slope & Low Slope	Class A, B & C	East-West	Landscape OR Portrait	None Required

UL2703 TEST MODULES

See page "S" for a list of modules that were electrically and mechanically tested or qualified with the SUNFRAME MICRORAIL (SFM) components outlined within this Installation Guide.

- Maximum Area of Module = 22.3 sqft
- UL2703 Design Load Ratings:
 - a) Downward Pressure – 113 PSF
 - b) Upward Pressure – 50 PSF
 - c) Down-Slope Load – 30 PSF
- Tested Loads:
 - a) Downward Pressure – 170 PSF / 8000 Pa
 - b) Upward Pressure – 75 PSF / 3500 Pa
 - c) Down-Slope Load – 45 PSF / 2100 Pa
- Maximum Span = 6ft
- Use with a maximum over current protection device OCPD of 30A

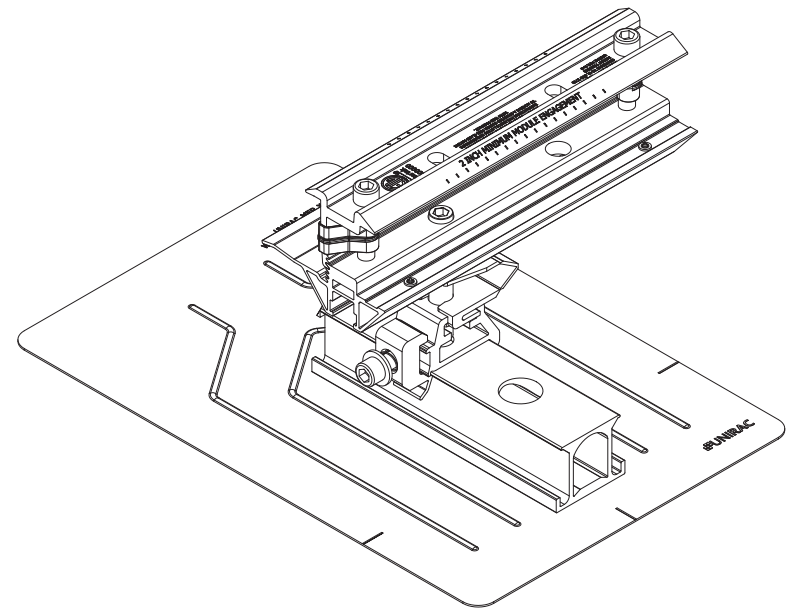

LABEL MARKINGS

- System fire class rating: See installation instructions for installation requirements to achieve a specified system fire class rating with Unirac.
- Unirac SUNFRAME MICRORAIL™ is listed to UL 2703.
- All splices within a system are shipped with marking indicating date and location of manufacture.

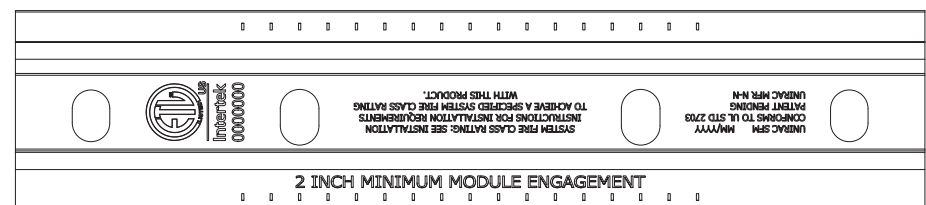

Manufacture	Module Model / Series
Aleo	P-Series
Auxin	AXN6M610T, AXN6P610T, AXN6M612T & AXN6P612T
Axitec	AXI Power, AXI Premium, AXI Black Premium
Boviet	BVM6610, BVM6612
BYD	P6K & MHK-36 Series
Canadian Solar	CS6V-M, CS6P-P, CS6K-M, CS5A-M, CS6K-MS, CS6U-P, CS6U-M, CS6X-P, CS6K-MS, CS6K-M, CS6K-P, CS6P-P, CS6P-M, CS3U-P, CS3U-MS, CS3K-P, CS3K-MS, CS1K-MS, CS3K, CS3U, CS3U-MB-AG, CS3K-MB-AG, CS6K, CS6U, CS3L, CS3W
Centrosolar America	C-Series & E-Series
CertainTeed	CT2xxMxx-01, CT2xxPxx-01, CTxxMxx-02, CTxxM-03
Eco Solargy	Orion 1000 & Apollo 1000
FreeVolt	Mono PERC
GCL	GCL-P6 & GCL-M6 Series
Hansol	TD-AN3, TD-AN4, UB-AN1, UD-AN1
Heliene	36M, 60M, 60P, 72M & 72P Series
HT Solar	HT60-156(M) (NDV) (-F), HT 72-156(M/P)
Hyundai	KG, MG, TG, RI, RG, TI, MI & KI Series
ITEK	iT, iT-HE & iT-SE Series
Japan Solar	JPS-60 & JPS-72 Series
JA Solar	JAP6 60-xxx, JAM6-60-xxx/SI, JAM6(K)-60/ xxx, JAP6(k)-72-xxx/4BB, JAP72SYY-xxx/ZZ, JAP6(k)-60-xxx/4BB, JAP60SYY-xxx/ZZ, JAM6(k)-72-xxx/ZZ, JAM72SYY-xxx/ZZ, JAM6(k)-60-xxx/ZZ, JAM60SYY-xxx/ZZ. i. YY: 01, 02, 03, 09, 10 ii. ZZ: SC, PR, BP, HiT, IB, MW

Manufacture	Module Model / Series
Jinko	JKM & JKMS Series
Kyocera	KU Series
LG Electronics	LG xxx S1C-A5, LG xxx N1C-A5, LGxxxQ1C(Q1K)-A5, LGxxxN1C(N1K)-A5, LGxxxS1CA5, LGxxxA1C-A5, LGxxxN2T-A4, LGxxxN2T-A5, LGxxxN2W-A5 LGxxxS2W-A5, LGxxxE1C-A5, LGxxxN1C(N1K)-G4, LGxxxN2W-G4, LGxxxS2W-G4, LGxxxS1C-G4, LGxxxE1K-A5
LONGi	LR6-60 & LR6-72 Series
Mission Solar Energy	MSE Series
Mitsubishi	MJE & MLE Series
Neo Solar Power Co.	D6M & D6P Series
Panasonic	VBHNxxxSA15 & SA16, VBHNxxxSA17 & SA18, VBHNxxxSA17(E/G) & SA18E VBHNxxxKA01 & KA03 & KA04
Peimar	SGxxxM (FB/BF)
Q_Cells	Plus, Pro, Peak, G3, L-G4, L-G2, G4, G5
REC	PEAK Energy Series, PEAK Energy BLK2 Series, PEAK Energy 72 Series, TwinPeak 2 Series, TwinPeak 2 BLK2 Series, TwinPeak Series
Renesola	Vitrus2 Series & 156 Series
Risen	RSM Series
S-Energy	SN72 & SN60 Series (40mm)
Seraphim	SEG-6 & SRP-6 Series
Sharp	NU-SA & NU-SC Series

Manufacture	Module Model / Series
Silfab	SLA-M & SLG-M Series
Solaria	PowerXT
SolarWorld	Sunmodule Protect, Sunmodule Plus
Suntech	STP
Suniva	MV Series & Optimus Series
Sun Edison/Flextronics	F-Series, R-Series & FLEX FXS Series
SunPower	X-Series, E-Series & P-Series
Talesun	TP572, TP596, TP654, TP660, TP672, Hipor M, Smart
Trina	PA05, PD05, DD05, PD14, PE14, DD14, DE14
Upsolar	UP-MxxxP, UP-MxxxP-B, UP-MxxxM, UP-MxxxM-B
Waaree	AC & Adiya Series
Winaico	WST & WSP Series
Yingli	YGE 60, YLM 60 & YLM 72 Series

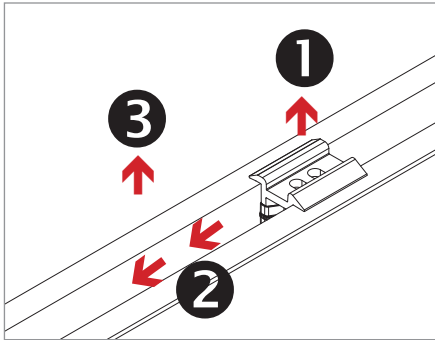

REMOVE 2" CAPS:
1. Remove capbolt 2. Separate cap from base by moving east/west 3. Remove cap

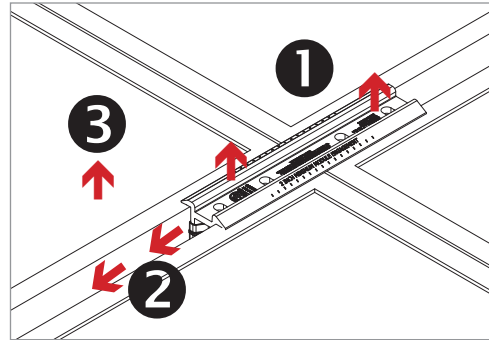

REMOVE 8" CAPS:
1. Remove (2) cap bolts 2. Separate cap from base by moving east/west 3. Remove cap

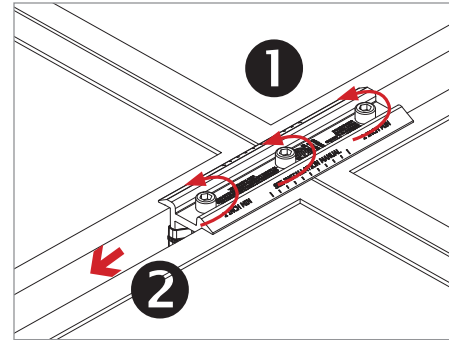

SLIDE FLOATING SPLICE:
1. Loosen (3) cap bolts approx. 3 turns. 2. Slide entire floating splice away from module being removed.

CAUTION: DO NOT FULLY REMOVE FASTENERS

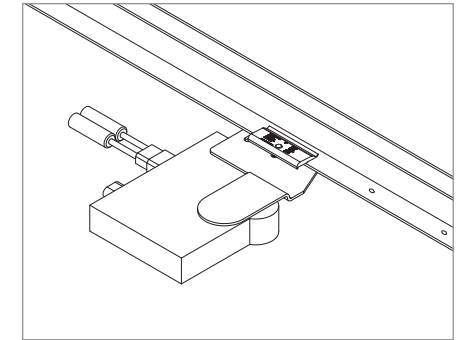

LIFT MODULE AND DISCONNECT MLPE CABLES

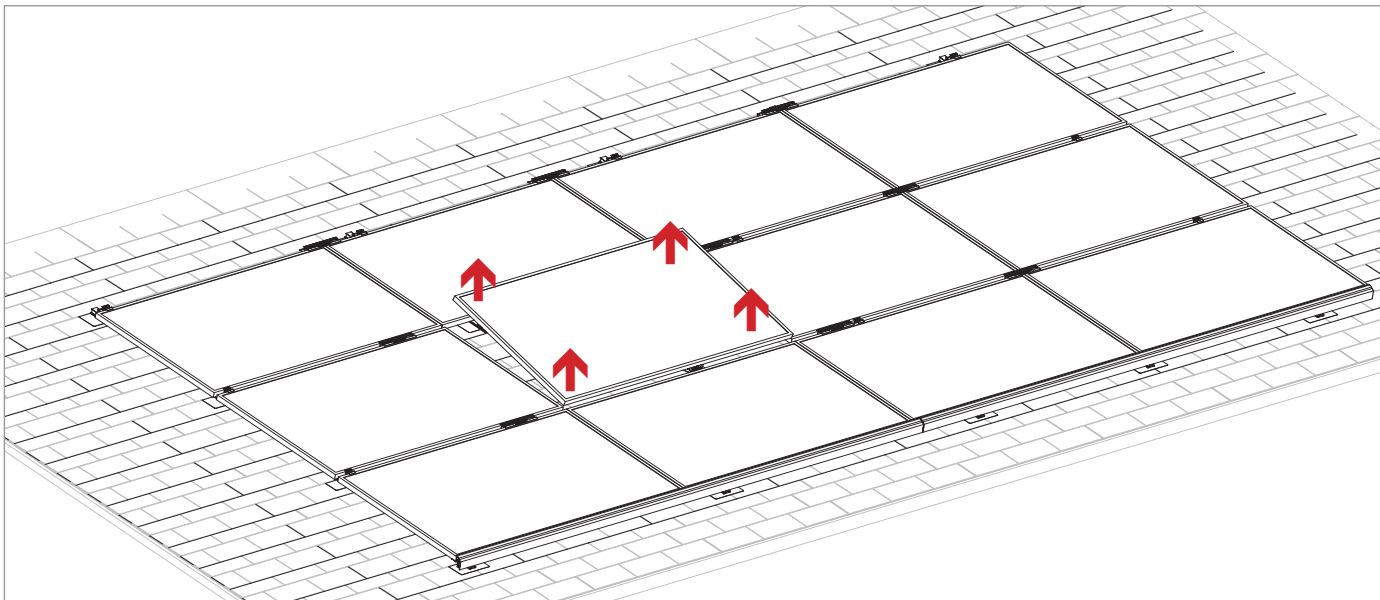

REMOVE MODULE. REVERSE STEPS TO REPLACE MODULE REMOVED

Bonding note: If both sides of array are bonded with NS Bonding Clips, as recommended, then no additional bonding is required for module maintenance.



If necessary, on the row of modules containing the module being removed, one additional bonding clip can be added to the edge of the array opposite of the edge with bonding clips already installed. This is only necessary when the module removal would break the bonding path.

ELECTRICAL CONSIDERATIONS

SUNFRAME Microrail is intended to be used with PV modules that have a system voltage less than or equal to that allowable by the NEC. A minimum 10AWG, 105°C copper grounding conductor should be used to ground a system, according to the National Electric Code (NEC). It is the installer's responsibility to check local codes, which may vary.

INTERCONNECTION INFORMATION

There is no size constraint beyond structural thermal expansion limits on how many SUNFRAME Microrails & PV modules can be mechanically interconnected for any given configuration, provided that the installation meets the requirements of applicable building and fire codes.

GROUNDING NOTES

The installation must be conducted in accordance with the National Electric Code (NEC) and the authority having jurisdiction. Please refer to these resources in your location for required grounding lug quantities specific to your project. The grounding / bonding components may overhang parts of the array so care must be taken when walking around the array to avoid damage. Conductor fastener torque values depend on conductor size.

This racking system may be used to ground and/or mount a PV module complying with UL 1703 only when the specific module has been evaluated for grounding and/or mounting in compliance with the included instruction

PERIODIC INSPECTION

Conduct periodic inspections for loose components, loose fasteners or any corrosion, immediately replace any affected components.