

# BX SYSTEM

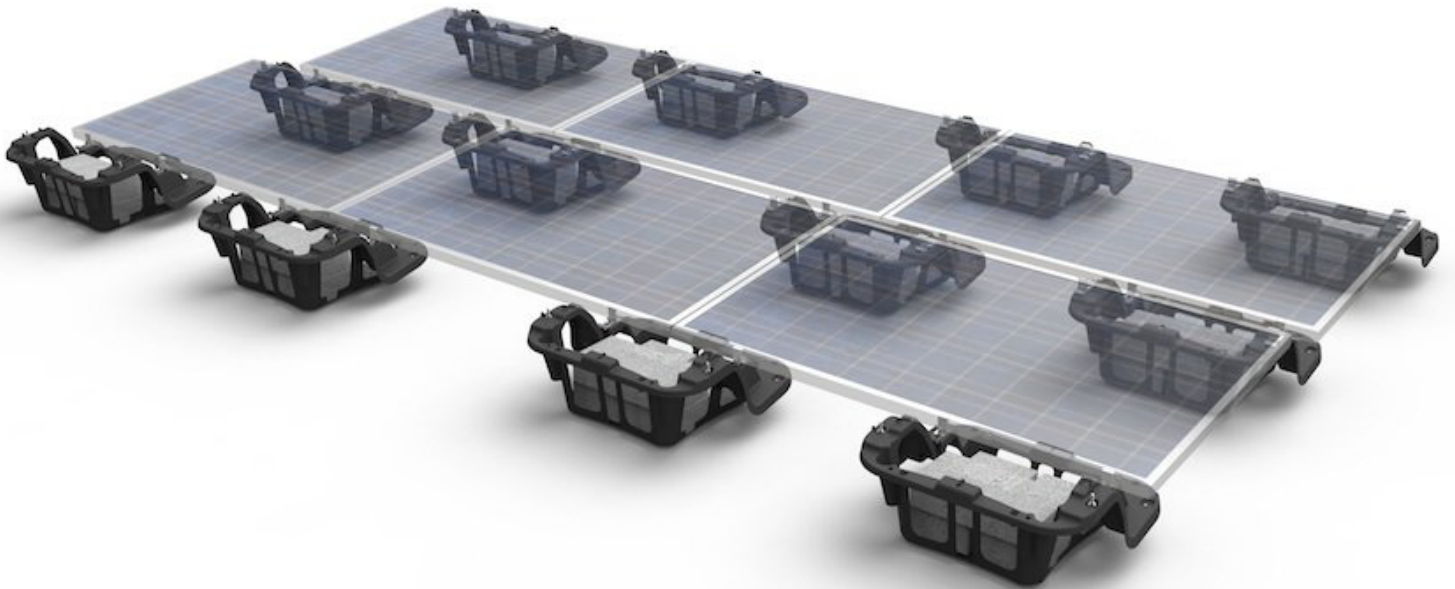

# CONTENTS

<b>DISCLAIMER</b>	<b>1</b>
<b>RATINGS</b>	<b>2</b>
<b>MARKINGS</b>	<b>2</b>
<b>CHECKLIST</b>	<b>3</b>
<b>OVERVIEW</b>	<b>4</b>
<b>INSTALLATION STEPS (QUICK GUIDE)</b>	<b>5</b>
<b>1. MARK LAYOUT</b>	<b>6</b>
<b>2. PLACE CHASSIS</b>	<b>6</b>
<b>3. MOUNT MLPE (OPTIONAL)</b>	<b>6</b>
<b>4. LAY BALLAST</b>	<b>7</b>
<b>5. ANCHOR SYSTEM (OPTIONAL)</b>	<b>7</b>
<b>6. INSTALL MODULES</b>	<b>8</b>
<b>7. COMPLETE BONDING</b>	<b>8</b>
<b>8. PV MODULE GROUNDING LUGS</b>	<b>9</b>
<b>STRING INVERTER MOUNTING KIT (OPTIONAL)</b>	<b>9</b>
<b>ELECTRICAL DIAGRAM</b>	<b>10</b>
<b>MODULE COMPATIBILITY</b>	<b>11</b>
<b>MODULE COMPATIBILITY</b>	<b>12</b>
<b>MODULE COMPATIBILITY</b>	<b>13</b>
<b>MODULE COMPATIBILITY</b>	<b>14</b>
<b>MODULE COMPATIBILITY</b>	<b>15</b>

## DISCLAIMER

This manual describes proper installation procedures and provides necessary standards required for product reliability. Warranty details are available at [IronRidge.com](http://IronRidge.com). All installers must thoroughly read this manual and have a clear understanding of the installation procedures prior to installation. Failure to follow these guidelines may result in property damage, bodily injury or even death.

### IT IS THE INSTALLER'S RESPONSIBILITY TO:

- Ensure safe installation of all electrical aspects of the array. All electrical installation and procedures should be conducted by a licensed and bonded electrician or solar contractor. Routine maintenance of a module or panel shall not involve breaking or disturbing the bonding path of the system. All work must comply with national, state and local installation procedures, product and safety standards.
- Comply with all applicable local or national building and fire codes, including any that may supersede this manual.
- Ensure all products are appropriate for the installation, environment, and array under the site's loading conditions.
- Use only IronRidge parts or parts recommended by IronRidge; substituting parts may void any applicable warranty.
- Review the [Design Assistant](#) to confirm design specifications.
- Ensure provided information is accurate. Issues resulting from inaccurate information are the installer's responsibility.
- Ensure bare copper grounding wire does not contact aluminum and zinc-plated steel components, to prevent risk of galvanic corrosion.
- If loose components or loose fasteners are found during periodic inspection, re-tighten immediately. Any components showing signs of corrosion or damage that compromise safety shall be replaced immediately.
- Provide an appropriate method of direct-to-earth grounding according to the latest edition of the National Electrical Code, including NEC 250: Grounding and Bonding, and NEC 690: Solar Photovoltaic Systems.
- Disconnect AC power before servicing or removing modules, AC modules, microinverters and power optimizers.
- Review module manufacturer's documentation for compatibility and compliance with warranty terms and conditions.

**CAUTION:** Module removal may disrupt the bonding path and could introduce the risk of electric shock. If during servicing a module is required to be removed, a bonding jumper shall be installed between the adjacent modules from where the module was removed to maintain the bond path.

## RATINGS

UL 2703 LISTED  
UL 3741 LISTED



#5014158

Intertek

**Conforms to STD UL 2703 Standard for Safety First Edition: Mounting Systems, Mounting Devices, Clamping/Retention Devices, and Ground Lugs for Use with Flat-Plate Photovoltaic Modules and Panels.**

- Max Overcurrent Protective Device (OCPD) Rating: 40A
- Max Module Size: 30.5ft<sup>2</sup>
- Module Orientation: Landscape
- System Level Allowable Design Load Rating: 30 PSF downward, 15 PSF upward, 5 PSF lateral.
- Actual system structural capacities are defined by PE stamped certification letters.

### CLASS A SYSTEM FIRE RATING PER UL 2703

- Any System Tilt with Modules Types 1, 2, 3, 13, 19, 25 & 29 on Low Slope Roofs (< 9.5 degrees)
- Any module-to-roof gap is permitted with no perimeter guarding required. This rating is applicable with any IronRidge or 3rd party roof attachment and with or without concrete blocks in the Chassis.
- Class A rated PV systems can be installed on Class A, B, and C roofs without affecting the roof fire rating.

### CONFORMS TO STD UL 3741 STANDARD FOR SAFETY PHOTOVOLTAIC HAZARD CONTROL SYSTEM

- Refer to BX UL 3741 Installation Addendum version 1.0 for full ratings, approved equipment and components, and installation requirements

### STRUCTURAL CERTIFICATION

- Designed and Certified for Compliance with the International Building Code & ASCE/SEI-7
- Wind Tunnel Testing by I.F.I.
- Approved for use on roof pitches up to 7 degrees (<=7 degrees)

## MARKINGS

Product markings are located on the top surface of the BX Chassis.

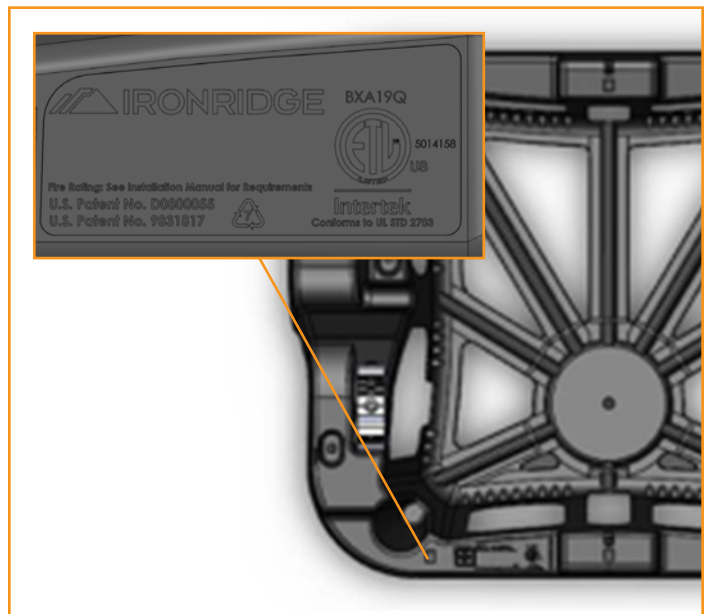

# CHECKLIST

## PRE-INSTALLATION

- Verify module compatibility. See [Page 11](#) for info.

## TOOLS REQUIRED

- Cordless Drill (optional)
- Torque Wrench (0-250 in-lbs)
- 9/16" Socket
- 7/16" Socket
- 1/2" Socket
- String Chalk Line

## TORQUE VALUES

- Top Clamp Nuts (1/2" Socket): 120 in-lbs
- 5/16" MLPE Flange Bolts (1/2" Socket): 60 in-lbs
- 5/16" String Inverter Mount Bolts (1/2" Socket): 80 in-lbs
- 5/16" L-Foot to Chassis Nuts (1/2" Socket): 120 in-lbs
- 3/8" T-Bolt Bonding Hardware (7/16" Socket): 250 in-lbs
- 1/4" String Inverter Mount Hdw (7/16" Socket): 80 in-lbs
- Flat Roof Attach to L-Foot Hdw (9/16" Socket): 250 in-lbs
- Module Grounding Lug Nut (1/2" Socket): 60 in-lbs
  - Grounding Lug Terminal Screws (3/8" Socket): 20 in-lbs

➤ Unless otherwise noted, all components have been evaluated for multiple use. They can be uninstalled and reinstalled in the same or new location.

## COMPONENTS

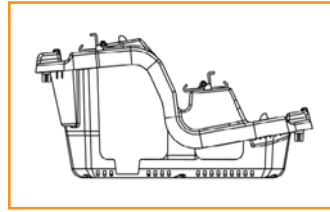

5° BX Chassis

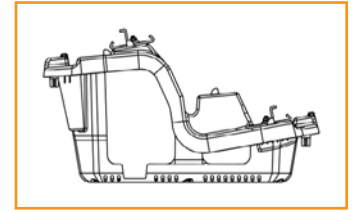

10° BX Chassis

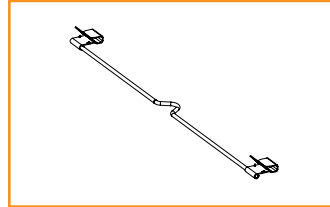

8" Module Bonding Jumper  
Single Use Only

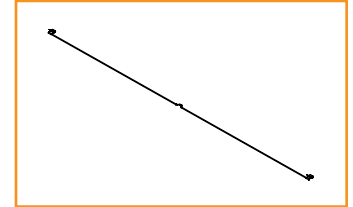

38" Row Bonding Jumper  
Single Use Only

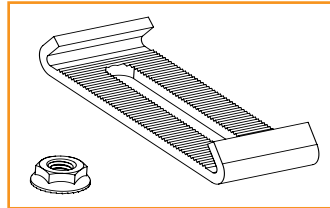

Bottom Clamp

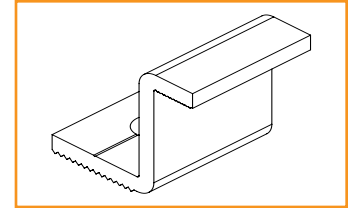

Top Clamp (Height Varies)

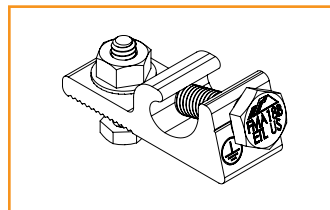

PV Module Grounding Lug

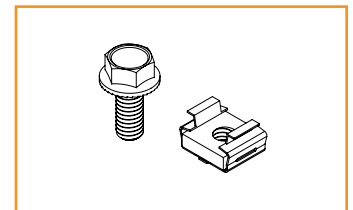

MLPE Mounting Hardware

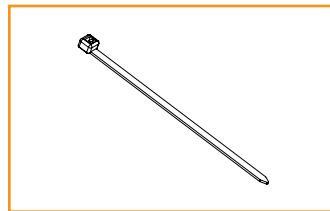

Cable Tie

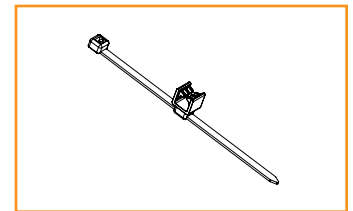

Edge Clip Cable Tie



String Inverter  
Mounting Kit

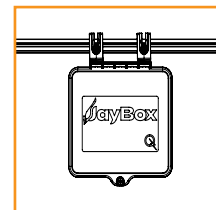

JayBox

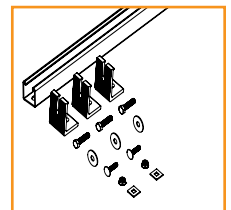

Flat Roof  
Attachment Kit

## OVERVIEW

### BX CHASSIS (5° & 10°)

BX Chassis is designed to clamp PV modules and secure them in place. Reference tabs are integrated to aid with aligning modules according to system layout. The Chassis is available in two SKUs: 5 and 10 degree tilt configurations. The Chassis is designed to accommodate 4 full size (16" x 8" x 4") or 8 half-size concrete ballast blocks (16" x 8" x 2") nominal dimensions.

Concrete ballast block must meet the following requirements:

- Manufactured per ASTM C 1491 (Standard specification for concrete pavers)
- Manufactured to resist freeze-thaw as required per local conditions
- Weight: 14-17 lbs +/- 2 lbs for half size and 28-34 lbs +/- 2 lbs for full size
- Compressive Strength requirement: 3000 PSI min

### MODULE CLAMPING

Top Clamps are module frame height specific and accommodate most common module sizes: 30mm, 31mm, 32mm, 33mm, 35mm, 38mm, 40mm, 46mm.

### ARRAY GROUNDING

Only one PV Module Grounding Lug is required per continuous array, regardless of array size. Use the IronRidge PV Module Grounding Lug (PV-LUG-01-A1).

Alternately, the following grounding lugs have been tested or evaluated for use with the BX system:

- IlSCO GBL-4DBT
- Amphenol HGLUI
- Burndy CL501TN, BGBS4

### MLPE DEVICES (OPTIONAL)

The following MLPE module mounting brackets have been tested or evaluated for use with the BX system:

- EcoFasten Frame MLPE Mount
- QMPV Accessory Frame Bracket

► Refer to respective installation instructions of MLPE module mounting brackets.

### WIRE MANAGEMENT

Optional Edge Clips and wire ties can be used to aid with wire management.

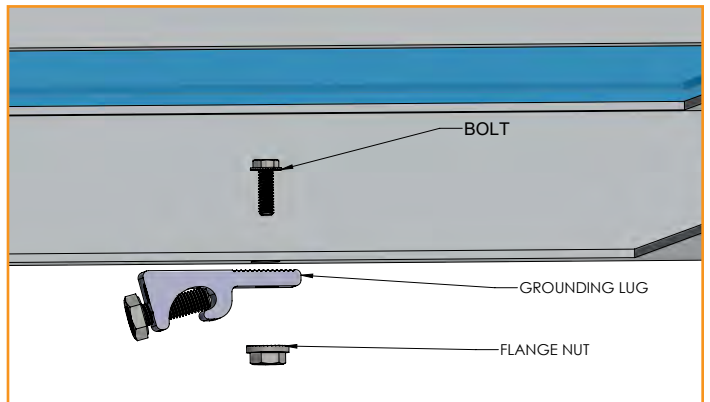
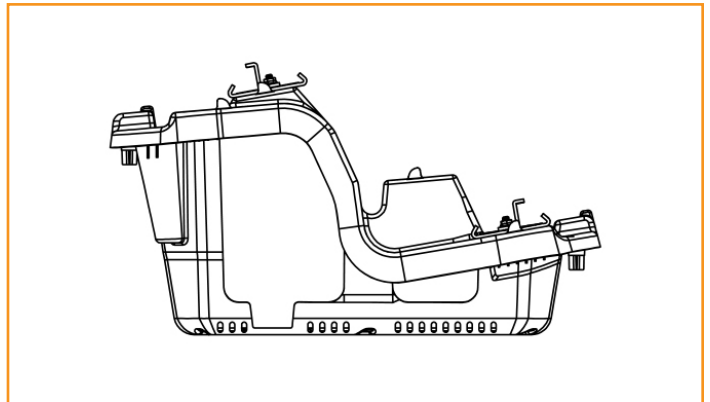
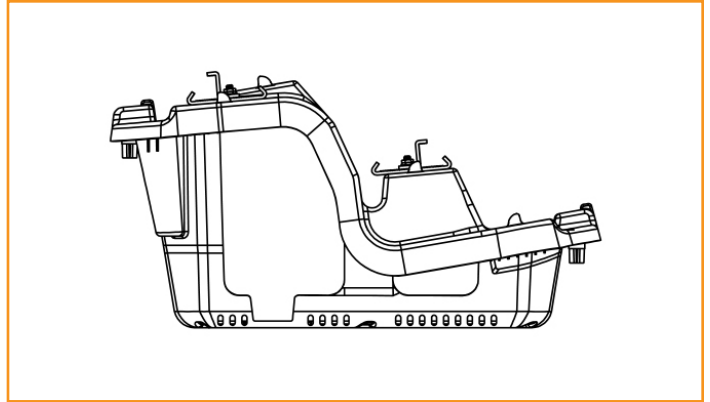

## INSTALLATION STEPS (QUICK GUIDE)

1. Mark out all fire setbacks on the roofing plane.
2. Measure and mark out footprint of array according to the approved plan set location.
3. Starting at the south edge of the approved plan set, chalk the South Array Edge, making sure that this line is at least 8" away from the South Fire Setback.
4. Measure Chassis spacing (refer to chart below) and chalk out 3 rows, 25' each.
5. Measure out the Chassis locations by marking along each row, module width plus 3/8".
6. Place Chassis on cross hairs. Align cross hairs with alignment marks on Chassis.
7. Install MLPE as needed.
8. Load Chassis with blocks as per the plan set.
9. Install fixed attachment points as required by the plan set for anchored hybrid systems, seal/flash in accordance with the roofing manufacturer's guidelines.
10. Module Installation
  - a. Place all Bottom Clamps on Chassis.
  - b. Land all panels on Chassis.
  - c. Place all Top Clamps and ensure proper alignment and engagement of the Bottom Clamp.
  - d. Make sure that all Clamps are fully engaged and square to the module and torqued appropriately.
11. Complete Array Bonding
  - a. Install 8" Module Bonding Jumpers between all modules along the rows.
  - b. Install 38" Row Bonding Jumpers between all rows.
12. Install PV Module Grounding Lug to ground each array.

It can be helpful on constrained arrays to chalk line every row, but it is not required.

The illustration below shows the order of chalk operations for marking out the starter array, as well as a corresponding Chassis spacing table which can be used to easily find the approx. Chassis spacing within 1/8". For more precise measurements use the formulas provided at the bottom of the table.

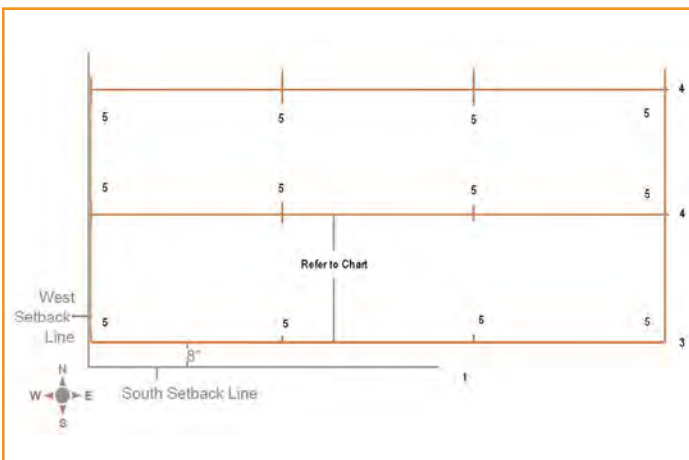

Module Width	5° Chassis Spacing	10° Chassis Spacing
38.5" - 39"	48.5"	51"
39" - 39.5"	49"	51.5"
39.5" - 40"	49.5"	52"
40" - 40.5"	50"	52.5"
40.5" - 41"	50.5"	53"
41" - 41.5"	51"	53.5"
41.5" - 42"	51.5"	54"
42" - 42.5"	52"	54.5"
42.5"+	52.5"	55"

Spacing Formulas: |  $\text{Width} \cos(5^\circ) + 10''$  |  $\text{Width} \cos(10^\circ) + 13''$

## 1. MARK LAYOUT

Using the approved planset, mark out all fire setbacks and the array footprint on the roof(s).

Mark the South Array Edge with a 25' line (for example). If the southern edge of the array is against the South Fire Setback, mark the South Array Edge at least 8" away from the setback. This will ensure that no part of the Chassis is in the setback.

Measure Chassis spacing (referring to table on [Page 5](#)) and chalk out 3x 25' rows. Then measure out the Chassis locations by marking along each row (module width plus 3/8").

- These layouts are useful for maintaining a straight line at the start of the array. Once started the rest of the system is build as you go.

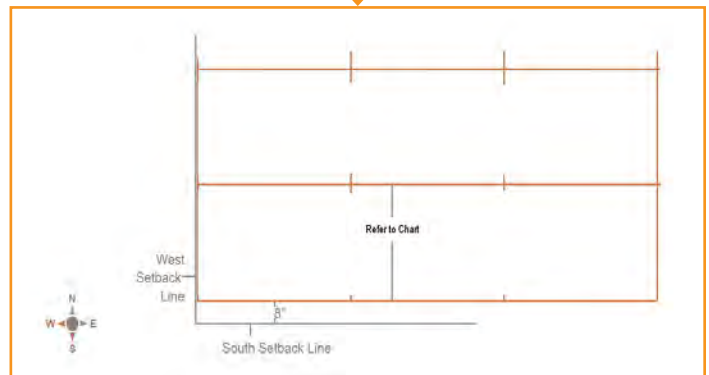
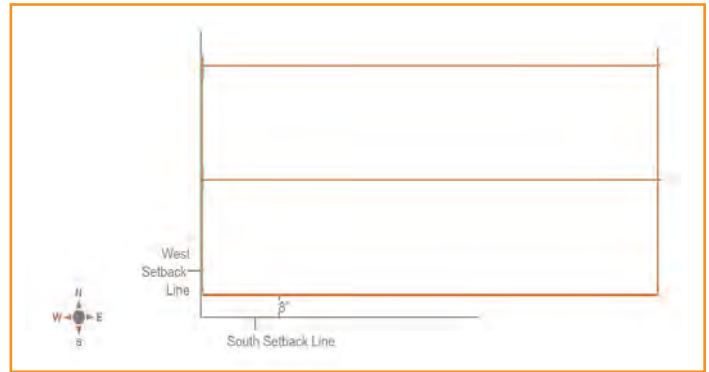

## 2. PLACE CHASSIS

Place first Chassis at Southwest corner of the array, aligning the center reference hole with the cross hair marker. Repeat for each additional Chassis in the array.

- After the array has been installed, the Chassis at the East and West edges of the array should be moved inward from the perimeter reference lines so that they are fully underneath the modules.

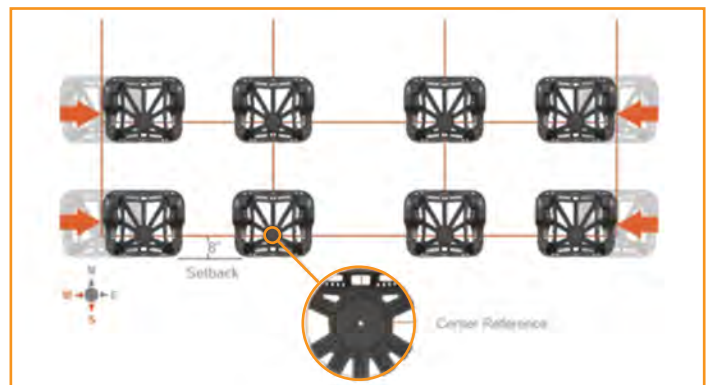

## 3. MOUNT MLPE (OPTIONAL)

Mount microinverters and power optimizers directly to the Chassis using the MLPE Mounting Hardware Kit. Alternatively, you can use a third party module mounting bracket (following manufacturer instructions).

To install the MLPE Mounting Hardware Kit, place the Cage Nut into either of the square cut-outs on the lower edge of a Chassis. Secure your MLPE device with a 5/16" Flange Bolt torqued to 60 in-lbs.

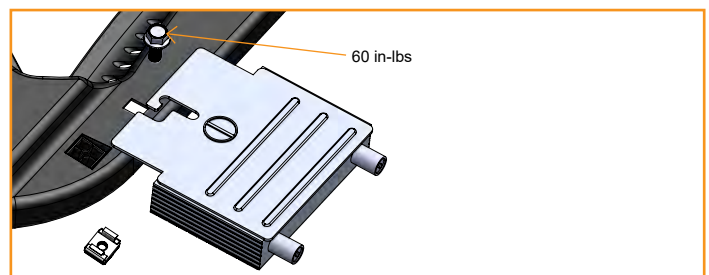

## 4. LAY BALLAST

Place ballast blocks in BX Chassis as indicated on site layout.

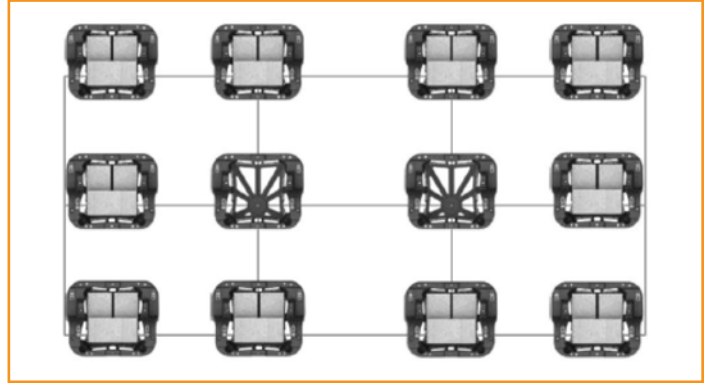

## 5. ANCHOR SYSTEM (OPTIONAL)

### A. SECURE L-FEET

The Attachment Kit uses an 8' minimum Galvanized Strut Channel with slotted holes to span across two Chassis and a Flat Roof Attachment(FRA) Anchor in order to anchor the Chassis to the roof. Secure L-Feet onto the Chassis by installing the Carriage Bolt and Square Washer from the underside of each Chassis through the reference hole. Torque Flange Nut to 120 in-lbs.

- Refer to Flat Roof Attachment [installation instructions](#) for details, where applicable.
- Flat Roof Attachment Kit is not part of the grounding path.

### B. ATTACH STRUT CHANNEL

Secure, at minimum, an 8' x 1-5/8" Galvanized Strut Channel with slotted holes, through the two Chassis onto the L-Feet using the provided 3/8" Bolt with 1-1/4" washer to a Channel Nut (not provided). Torque Nut to 250 in-lbs.

### C. FINISH ANCHORS

Assemble an L-Foot onto the FRA Anchor and flashing membrane (where applicable) using the 3/8" Bolt and Flat Washer torqued to 250 in-lbs. Then, install L-Foot and Flat Roof Attachment assembly at the Strut Channel midpoint using the provided 3/8" Bolt with a 1-1/4" Washer to a Channel Nut (as before) torqued to 250 in-lbs.

- After anchor assembly is installed seal/flash per roofing manufacturer's guidelines.
- Anchors shall not be located on a perimeter south row.
- The following 3rd party roof attachment has been tested or evaluated for use with BX:
  - Anchor Products U-Anchors

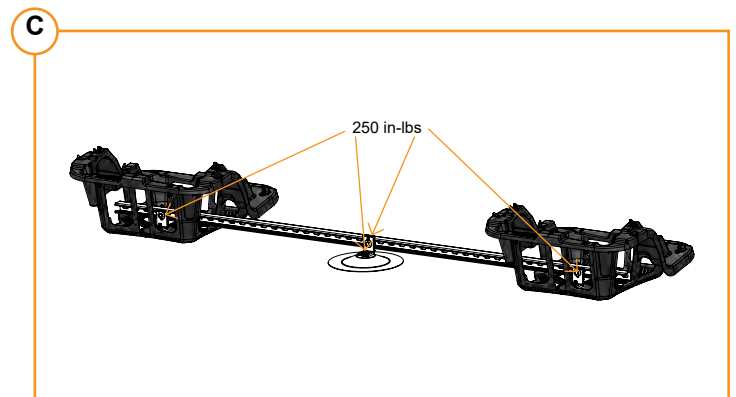
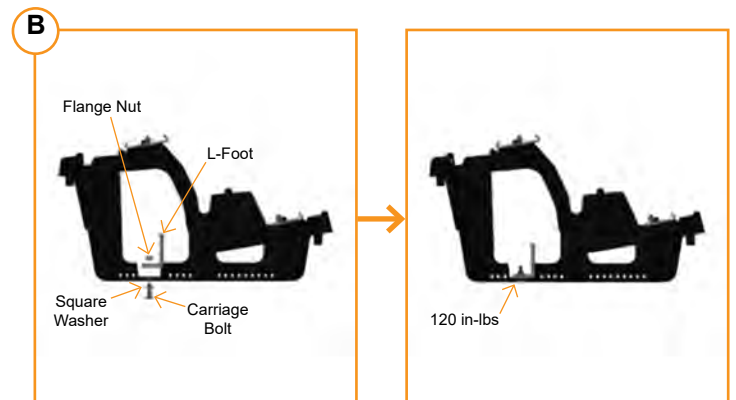
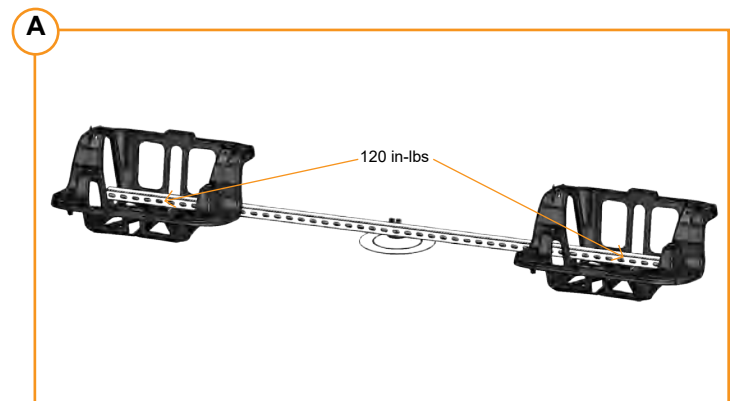



## 6. INSTALL MODULES

### A. PLACE CLAMPS

Place Bottom Clamp over the Chassis' corner bolt, then pull clamp towards the outer edge.

- The north end of the North Row and south end of the South Row do not need bottom clamps.
- When a Chassis is shifted inwards under a module, clamps should be installed on all corner bolts supporting the module.

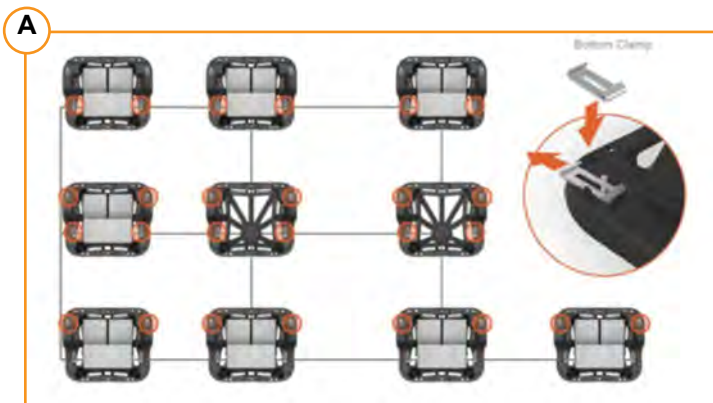

### B. LAY MODULES

Starting in the South-West corner and working east, lay modules in a row onto edge of Bottom Clamps. Double-check panel spacing along each row.

- You can use reference tabs located in the middle of the Chassis to properly space modules.

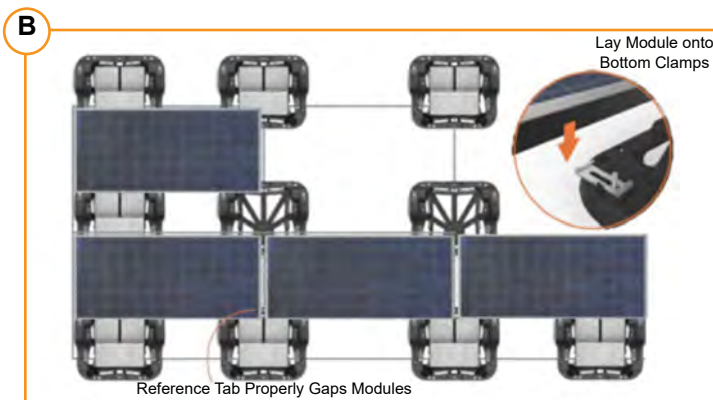

### C. SECURE MODULES

To secure a module, first pull the Bottom Clamp until it is snug against the inner flange of the module. Then place the Top Clamp and Flange Nut over the bolt and torque to 120 in-lbs.

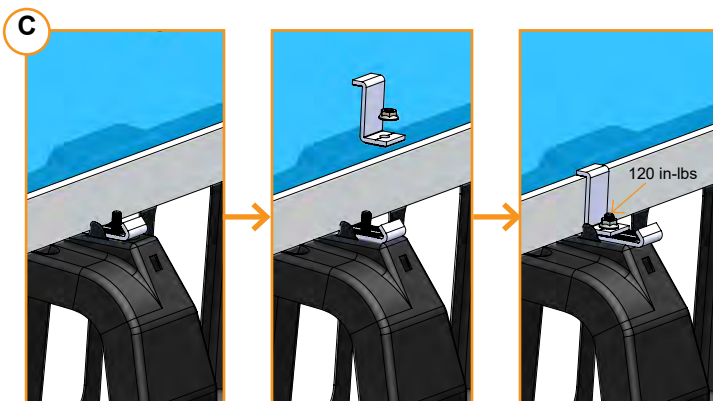

## 7. COMPLETE BONDING

### A. MODULE-TO-MODULE BONDING

The 8" Bonding Jumper is an electrical bonding jumper that can be used for module to module bonding.

- New jumpers should be used if re-installation of jumper is required.
- Jumpers are installed on the bottom flange of modules.
- Supports flange thicknesses 1.2mm to 3.1mm.



## 7. COMPLETE BONDING (CONTINUED)

### B. ROW-TO-ROW BONDING

The 38" Bonding Jumper is an electrical bonding jumper that should be used for row to row bonding by securing Clips to inner flanges on long side of a module from each row, as shown. Tapping Clips into place may be required for modules with thicker flanges.

- The bonding does not need to take place on the same side of the array, so long as every row is bonded to the next row.

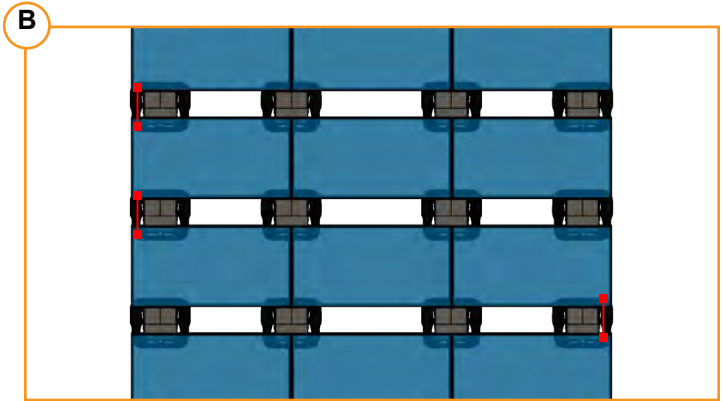

## 8. PV MODULE GROUNDING LUGS

Ground each continuous array by securing a PV Module Grounding Lug to any module in the array.

- Only one PV Module Grounding Lug is required per continuous array, regardless of array size. Reference module manufacturer's installation instructions for grounding location.

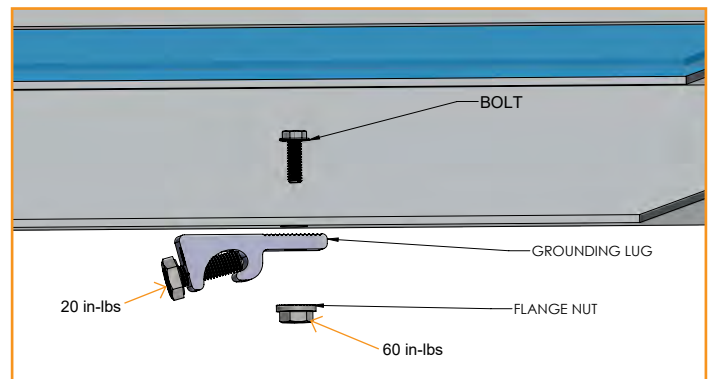

## STRING INVERTER MOUNTING KIT (OPTIONAL)

The String Inverter Mounting Kit creates a mounting platform for inverters on top of the BX Chassis.

### A. CROSS RAILS

Cut provided rails to length, as needed. Install four Cage Nuts in the square holes on the edges of the Chassis. Then, install an L-Foot into each Cage Nut location using a 5/16" bolt tightened to 80 in-lbs. Attach rails to L-Feet using 3/8" T-bolt bonding hardware tightened to 250 in-lbs.

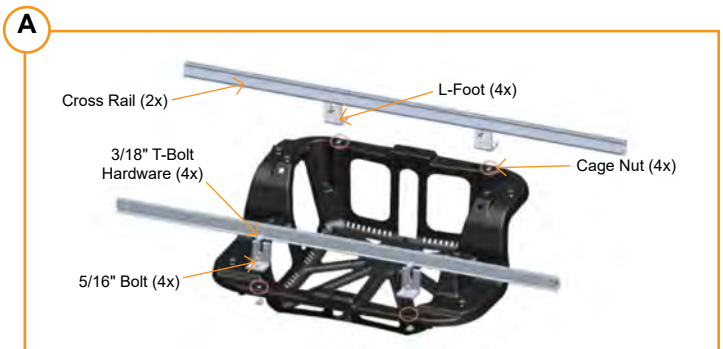

### B. TOP RAILS

Assemble the top rails using four L-Feet on top of cross rails. Install four L-Feet on top of the cross rails using 1/4" T-bolt and nut tightened to 80 in-lbs. Attach top rails to L-Feet using 3/8" T-bolt Bonding Hardware tightened to 250 in-lbs. Space top rails according to the mounting requirements for the inverter being used.

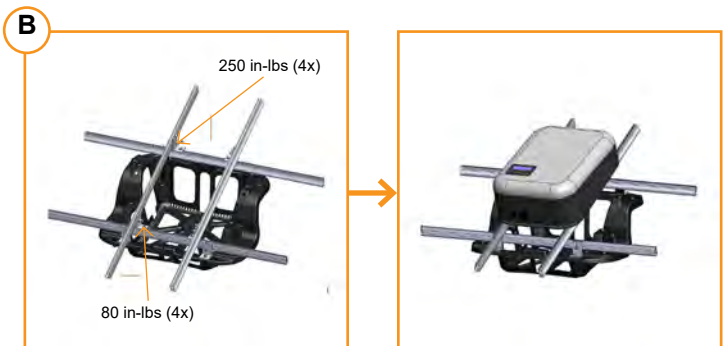

## JAYBOX INSTALLED WITH STRING INVERTER MOUNTING KIT

**A.**  
Prior to installation, use step drill bit to place pass through holes for conduits or water-tight connectors. Drill bit starter locations are provided on the sides and front of enclosure.

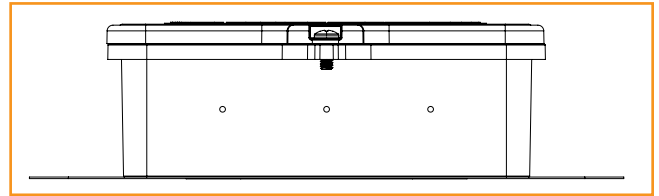

**B.**  
Use rail-specific MLPE mounting hardware to attach Rail Hangers to rail. Install only on the String Inverter Mounting Kit. Ensure junction box is pushed as close to the rail as possible. Torque to 80-in lbs (1/2" or 7/16" socket).

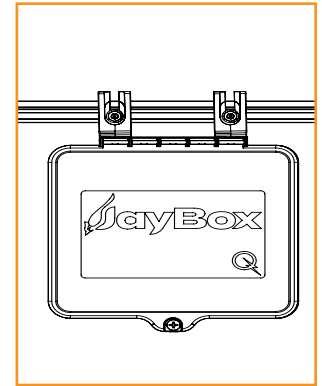
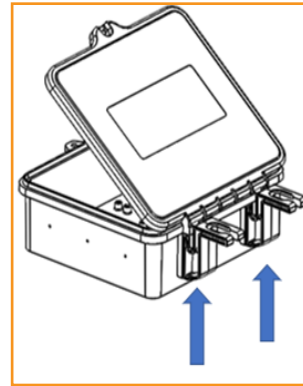

➤ Do not overtighten.

**C.**  
Install wiring, conduit and fittings per NEC requirements and following local AHJ guidance. Using Philips Head Driver tighten the bolt.

➤ For additional details refer to the full QM [Installation Manual](#).

## ELECTRICAL DIAGRAM

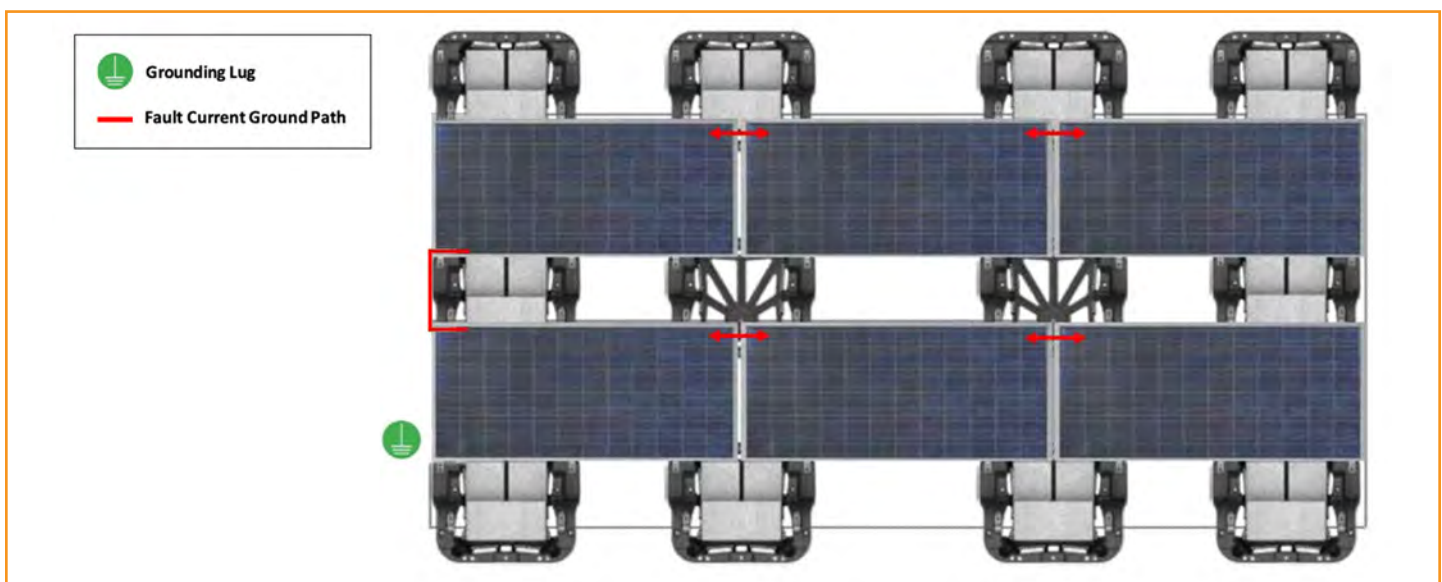

## MODULE COMPATIBILITY

The BX System may be used to ground and/or mount a PV module complying with UL 2703 only when the specific module has been evaluated for grounding and/or mounting in compliance with the included instructions. Unless otherwise noted, “xxx” refers to the module power rating and both black and silver frames are included in the certification.

MAKE	MODELS
Adani	Adani modules with 35 and 40mm frames ASX-Y-ZZ-xxx Where "X" can be B, M or P; "Y" can be 6, 7 or M10 and "ZZ" can be blank, 144, PERC, B-PERC, or AB-PERC
AIONRISE	AIONRISE modules with 35 and 40mm frames AIONyyG1-xxx Where "yy" can be 60 or 72
Amerisolar	Amerisolar modules with 35 and 40 mm frames AS-bYxxxZ Where "b" can be 5 or 6; "Y" can be M, P, M27, P27, M30, or P30; and "Z" can be blank, W or WB
Aptos Solar	Aptos modules with 35 and 40 mm frames DNA-yy-zzaa-xxx Where "yy" can be 120 or 144; "zz" can be MF or BF; and "aa" can be 23 or 26
Astronergy Solar	Astronergy modules with 30, 35 and 40 mm frames aaSMbbyyC/zz-xxx Where "aa" can be CH or A; "bb" can be 60, 66, or 72; "yy" can be blank, 10 or 12; "C" can M, P, M(BL), M-HC, M(BL)-HC, P-HC, M(DG), or M(DGT); and "zz" can be blank, HV, F-B, or F-BH
ASUN	ASUN modules with 35 and 40 mm frames ASUN-xxx-YYZZ-aa Where "YY" can be 60 or 72; "ZZ" can be M, or MH5; and "aa" can be blank or BB
Auxin	Auxin modules with 40 mm frames AXN6y6zAxxxB Where "y" can be M or P; "z" can be 08, 09, 10, 11, or 12; and "A" can be F, M or T; and "B" can be blank, A, B or C
Axitec	Axitec Modules with 30, 35 and 40 mm frames AC-xxxY/aaZZb Where "Y" can be M, P, MB or MH; "aa" can be blank, 125- or 156-; "ZZ" can be 54, 60, 72, 108, 120, or 144; "b" can be S, X, V, VB, XV, or MX
Bluesun Solar	Bluesun modules with 30 and 35mm frames BSMxxxY-AAA Where "Y" can be M or M10; and "AAA" can be 60HPH or 72HBD
Boviet	Boviet modules with 35 and 40mm frames BVMZZaaYY-xxxBcc Where "ZZ" can be 66 or 76; "aa" can be 9, 10 or 12; "YY" is M or P; and "B" can be blank, L or S; and "cc" can be blank, H, H-BF, H-BF-DG, H-HC, H-HC-BF, H-HC-BF-DG, HC-BF or HC-BF-DG
BYD	BYD modules with 35 mm frames BYDxxxAY-ZZ Where "A" can be M6, P6, MH or PH; "Y" can be C or K; and "ZZ" can be 30 or 36
Canadian Solar	Canadian Solar modules with 30, 32, 35 and 40 mm frames CSbY-xxxZ Where "b" can be 1, 3, 6 or 7 "Y" can be H, K, L, N, P, R, U, V, W, X or Y; and "Z" can be M, P, MS, PX, M-SD, P-AG, P-SD, MB-AG, PB-AG, MS-AG, MS-HL, or MS-SD
CertainTeed	CertainTeed modules with 35 and 40 frames CTxxxYZZ-AA Where "Y" can be M, P, or HC; "ZZ" can be 00, 01, 10, or 11; and "AA" can be 01, 02, 03, 04 or 06

## MODULE COMPATIBILITY

CSUN	Csun modules with 35 and 40 mm frames YYxxx-zzAbb Where "YY" is CSUN or SST; "zz" is blank, 60, or 72; and "A" is blank, P, M or MM; "bb" is blank, BB, 5BB, BW, or ROOF
Dehui	Dehui modules with 30, 35 and 40mm frames DH-MYYYYZ-xxx Where "YYYY" can be 760, 772, 860, 872; and "Z" can be B, F or W
Ecosolargy	Ecosolargy modules with 35 and 40 mm frames ECOxxxYzza-bbD Where "Y" can be A, H, S, or T; "zz" can be 125 or 156; "A" can be M or P; "bb" can be 60 or 72; and "D" can be blank or B
ET Solar	ET Solar modules with 30, 35 and 40 mm frames ET-YZZZxxxAA Where "Y" can be P, L, or M; "ZZZ" can be 660, 660BH, 672, 672BH, 754BH, 766BH, 772BH; and "AA" can be GL, TB, TW, WB, WW, BB, WBG, WWG, WBAC, WBCO, WWCO, WWBCO or BBAC
Flex	Flex modules with 35 and 40 mm frames FXS-xxxYY-ZZ; Where "YY" can be BB or BC; and "ZZ" can be MAA1B, MAA1W, MAB1W, SAA1B, SAA1W, SAC1B, SAC1W, SAD1W, SBA1B, SBA1W, SBC1B, or SBC1W
Freedom Forever	Freedom Forever modules with 35mm frames FF-MP-BBB-xxx
GCL	GCL modules with 35 mm and 40 mm frames GCL-ab/YY xxx Where "a" can be M or P; "b" can be 3 or 6; and "YY" can be 60, 72, 72H, or 72DH
GigaWatt Solar	Gigawatt modules with 40 mm frames GWxxxYY Where "YY" can be either PB or MB
Hansol	Hansol modules with 35 and 40 frames HSxxxYY-zz Where "YY" can be PB, PD, PE, TB, TD, UB, UD, or UE; and "zz" can be AH2, AN1, AN3, AN4, HH2, HV1, or JH2
Hanwa Solar	Hanwha Solar modules with 40 mm frames HSLaaP6-YY-1-xxxZ Where "aa" can be either 60 or 72; "YY" can be PA or PB; and "Z" can be blank or B
Hanwha Q CELLS	Hanwha Q CELLS Modules with 32, 35, 40mm frames aaYY-ZZ-xxx where "aa" can be Q. or B.; "YY" can be PLUS, PRO, PEAK, LINE PRO, LINE PLUS, PLUS DUO or PEAK DUO; and "ZZ" can be G3, G3.1, G4, G4.1, L-G2, L-G2.3, L-G3, L-G3.1, L-G3y, L-G4, L-G4.2, L-G4y, LG4.2/TAA, BFR-G3, BLK-G3, BFR-G3.1, BLK-G3.1, BFR-G4, BFR-G4.1, BFR G4.3, BLK-G4.1, G4/SC, G4.1/SC, G4.1/TAA, G4.1/MAX, BFR G4.1/TAA, BFR G4.1/MAX, BLK G4.1/TAA, BLK G4.1/SC, EC-G4.4, G5, G5/SC, G5/TS, BLK-G5, BLK-G5/SC, BLK-G5/TS, L-G5, L-G5.1, L-G5.2, L-G5.2/H, L-G5.3, G6, G6/SC, G6/TS, G6+/TS, G6+, BLK-G6, L-G6, L-G6.1, L-G6.2, L-G6.3, G7, BLK-G6+, BLK-G6+/AC, BLK-G6+/HL, BLK-G6+/SC, BLK-G6/TS, BLK-G6+/TS, BLK-G7, G7.2, G8, BLK-G8, G8+, BLK-G8+ L-G7, L-G7.1, L-G7.2, L-G7.3, L-G8, L-G8.1, L-G8.2, L-G8.3, L-G8.3/BFF, L-G8.3/BFG, L-G8.3/BGT, ML-G9, BLK ML-G9, ML-G9+, BLK ML-G9+, BLK ML-G10+, BLK G10+/AC, ML-G10, BLK ML-G10, ML-G10+, BLK ML-G10+, ML-G10.a, BLK ML-G10.a, ML-G10.a+, BLK ML-G10.a+, XL-G9, XL-G9.2, XL-G9.3, XL-G9.3/BFG, XL-G10.2, XL-G10.3, XL-G10.c, XL-G10.d, XL-G10.d/BFG, XL-G10.3/BFG, XL-G11.2, XL-G11.3 or XL-G11.3/BFG
Heliene	Heliene modules with 35 and 40 mm frames YYZZxxxA Where "YY" can be 36, 60, 72, 96, 120 or 144; "ZZ" can be HC, M, P, or MBLK; and "A" can be blank, HomePV, Bifacial, M10 Bifacial or M10 SL-Bifacial
HT-SAAE	HT-SAAE modules with 35 and 40 mm frames HTyy-aaaZ-xxx Where "yy" can be 60, 66, 72 or 78, "aaa" can be 18, 156 or 166, "Z" can be M, P, M-C, P-C, M(S), M(VS), M(V), P(V), M(V)-C, P(V)-C, or X

## MODULE COMPATIBILITY

Hyundai	Hyundai modules with 32, 33, 35 and 40mm frames HiY-SxxxZZ Where "Y" can be A, D or S; "S" can be M or S; and "ZZ" can be GI, HG, HI, KI, MI, MF, MG, PI, RI, RG, RG(BF), RG(BK), SG, TI, TG, YH(BK) or XG(BK)
Itek	Itek Modules with 40 mm frames IT-xxx-YY Where "YY" can be blank, HE, or SE, or SE72
JA Solar	JA Solar modules with 30, 35 and 40 mm frames JAyzzz-bbww-xxx/aa Where "yy" can be M, P, M6 or P6; "zz" can be blank, (K), (L), (R), (V), (BK), (FA), (TG), (FA)(R), (L)(BK), (L)(TG), (R)(BK), (R)(TG), (V)(BK), (BK)(TG), or (L)(BK)(TG); "bb" can be 48, 54, 60, 66, 72 or 78; "ww" can be D09, D10, D20, D30, S01, S02, S03, S06, S09, S10, S12, S17, S20, S30 or S31; and "aa" can be BP, MB, MR, SI, SC, PR, 3BB, 4BB, 4BB/RE, 5BB
Jinko	Jinko modules with 35 and 40 mm frames JKMYxxxZZ-aa Where "Y" can either be blank or S; "ZZ" can be M, P, or PP; and "aa" can be blank, 60, 60B, 60H, 60L, 60BL, 60HL, 60HB, 60HBL, 6HBL-EP, 60-J4, 60B-J4, 60B-EP, 60(Plus), 60-V, 60-MX, 6RL3, 6RL3-B, 6TL3-B, 7RL3-V, 7RL3-TV, 72, 72B, 72-J4, 72B-J4, 72(Plus), 72-V, 72H-V, 72L-V, 72HL-V, 72HL4-V, 72HL4-TV, 72-MX, 72H-BDVP, 72HL-TV, or 72HL-V-MX3
Kyocera	Kyocera Modules KYxxxZZ-AA Where "Y" can be D or U; "ZZ" can be blank, GX, or SX; and "AA" can be LPU, LFU, UPU, LPS, LPB, LFB, LFBS, LFB2, LPB2, 3AC, 3BC, 3FC, 4AC, 4BC, 4FC, 4UC, 5AC, 5BC, 5FC, 5UC, 6BC, 6FC, 8BC, 6MCA, or 6MPA
LG	LG modules with 35 and 40 mm frames LGxxxYaZ-bb Where "Y" can be A, E, M, N, Q, S; "a" can be A, 1, 2 or 3 "Z" can be C, K, T, or W; and "bb" can be A3, A5, A6, B3, B6, E6, E6.AW5, G3, G4, J5, K4, L5, N5, V5, V6
Longi	Longi modules with 30, 35 and 40 mm frames LRa-YYZZ-xxxM Where "a" can be 4, 5 or 6; "YY" can be blank, 60, 66, or 72; and "ZZ" can be blank, BK, BP, HV, PB, PE, PH, HBD, HIB, HIH, HPB, HPH, or HIBD
Maxeon	Maxeon modules with 35, 40 and 46mm frames SPR-AAAY-xxx-zzz Where "AAA" can be MAX, P or X; "Y" can be 3, 5, 6, 21 or 22; and "zzz" can be BLK, COM or UPP
Mission Solar	Mission Solar modules with 33, 35 and 40 mm frames YYYbb-xxxZZaa Where "YYY" can be MSE or TXS; "bb" can be blank, 6 or 60A; "ZZ" can be blank, MM, SE, SO, SQ, SR, SX, TS, 120 or 144; and "aa" can be blank, BB, BW, 1J, 4J, 4S, 5K, 5R, 5T, 60, 6J, 6S, 6W, 6Z, 8K, 8T, or 9S
Mitsubishi	Mitsubishi modules PV-MYYxxxZZ Where "YY" can be LE or JE; and "ZZ" can be either HD, HD2, or FB
Moltech	IM and XS series modules with 40 mm frames
Next Energy Alliance	Next Energy Alliance modules with 35 and 40mm frames yyNEA-xxxZZ where "yy" can be blank or US; "ZZ" can be M, MB or M-60
Neo Solar Power	Neo Solar Power modules with 35 mm frames D6YxxxZZaa Where "Y" can be M or P; "ZZ" can be B3A, B4A, E3A, E4A, H3A, H4A; and "aa" can be blank, (TF), ME or ME (TF)

## MODULE COMPATIBILITY

Panasonic (HIT)	Panasonic modules with 35 and 40 mm frames VBHNxxxYYzzA Where "YY" can be either KA, RA, SA or ZA; "zz" can be either 01, 02, 03, 04, 06, 06B, 11, 11B, 15, 15B, 16, 16B, 17, or 18; and "A" can be blank, E, G, or N
Panasonic (EverVolt)	Panasonic modules with 30 mm frames EVPVxxxA Where "A" can be blank or H, K or PK
Peimar	Peimar modules with 40 mm frames SbxxxYzz Where "b" can be G, M or P; "Y" can be M or P; and "zz" can be blank, (BF) or (FB)
Philadelphia Solar	Philadelphia modules with 35 and 40 mm frames PS-YzzAA-xxx Where "Y" can be M or P; "zz" can be 60, 72 or 144; and "AA" can be blank, (BF), (HC) or (HCBF)
Phono Solar	Phono Solar modules with 30, 35 and 40mm frames PSxxxY-ZZ/A Where "Y" can be M, M1, MH, M1H, M4, M4H, M5GF, M5GFH, M6, M6H, M8GF, M8GFH or P; "ZZ" can be 18, 20 or 24; and "A" can be F, T, TH, U, UH, UHB, VH or VHB
Prism Solar	Prism Solar modules with 35mm frames PST-xxxW-M72Y Where "Y" can be H, HB or HBI
Recom	Recom modules with 35 and 40 mm frames RCM-xxx-6yy Where "yy" can be MA, MB, ME or MF
REC Solar	REC modules with 30 and 38 mm frames RECxxxYYZZ Where "YY" can be AA, M, NP, NP2, PE, PE72, TP, TP2, TP2M, TP2SM, TP2S, TP3M or TP4; and "ZZ" can be blank, Black, BLK, BLK2, SLV, 72, or Pure
Renesola	ReneSola modules with 35 and 40 mm frames AAxxxY-ZZ Where "AA" can be SPM(SLP) or JC; "Y" can be blank, F, M or S; and "ZZ" can be blank, Ab, Ab-b, Abh, Abh-b, Abv, Abv-b, Bb, Bb-b, Bbh, Bbh-b, Bbv, Bbv-b, Db, Db-b, or 24/Bb
Renogy	Renogy Modules with 40 mm frames RNG-xxxY Where "xxx" is the module power rating; and "Y" can be D or P
Risen	Risen Modules with 30, 35 and 40 mm frames RSMyy-a-xxxZZ Where "yy" can be 60, 72, 110, 120, 132 or 144; "a" can be 6, 7 or 8; and "ZZ" can be M, P or BMDG
S-Energy	S-Energy modules with 35 and 40mm frames SABB-CCYYY-xxxZ Where "A" can be C, D, L or N; "BB" can be blank, 20, 25, 40 or 45; "CC" can be blank, 60 or 72; "YYY" can be blank, BDE, MAE, MAI, MBE, MBI, MCE or MCI; and "Z" can be V, M-10, P-10 or P-15
SEG Solar	SEG Solar with 30, 35 and 40 mm frames SEG-aYY-xxxZZ Where "a" can be blank, 6 or B; "YY" can be blank, MA, MB, PA, or PB; and "ZZ" can be blank, BB, BG, BW, HV, WB, WW, BMB, BMA-HV, BMA-BG, BMA-TB, BMB-TB, BMB-HV, BMD-HV, BMB-BG
Seraphim USA	Seraphim modules with 30, 35 and 40 mm frames SRP-xxx-YYY-ZZ Where "xxx" is the module power rating; and "YYY" can be BMA, BMD, 6MA, 6MB, 6PA, 6PB, 6QA-XX-XX, and 6QB-XX-XX; ZZ is blank, BB, BG or HV
Sharp	Sharp modules with 35 and 40 mm frames NUYYxxx Where "YY" can be SA or SC

## MODULE COMPATIBILITY

Shinsung E&G	Shinsung Modules with 35mm frames SSVxxx-144MH
Silfab	Silfab Modules with 35 and 38 mm frames SYY-Z-xxxAb Where "YY" can be IL, SA, LA, SG or LG; "Z" can be blank, M, P, or X; "A" can be blank, B, H, M, N; and "b" can be A, C, G, K, L, N, T, U or X
Solaria	Solaria modules with 35 and 40 mm frames PowerA-xxxY-ZZ Where "A" can be X or XT, "Y" can be R or C; and "ZZ" can be blank, AC, BD, BX, BY, PD, PL, PM, PM-AC, PX, PZ, WX or WZ
Solarcity (Tesla)	Solarcity modules with 40 mm frames SCxxxYY Where "YY" can be blank, B1 or B2
SolarTech	SolarTech modules with 40 mm frames AAA-xxxYY Where "AAA" can be PERCB-B, PERCB-W, HJT B-B, HJT B-W or STU; "YY" can be blank, PERC or HJT
SolarWorld AG	SolarWorld Sunmodule Plus, Protect, Bisun, XL, Bisun XL, may be followed by mono, poly, duo, black, bk, or clear; modules with 31 and 33 mm frames SW-xxx
SolarWorld Americas	SolarWorld Sunmodule Plus, Protect, Bisun, XL, Bisun XL, may be followed by mono, poly, duo, black, bk, or clear; modules with 33 mm frames SWA-xxx
Sonali	Sonali Modules with 35 and 40 mm frames SS-M-xxx Where "M" can be blank or M
Stion	Stion Thin film modules with 35 mm frames STO-xxx or STO-xxxA
SunEdison	SunEdison Modules with 35 and 40 mm frames SE-YxxxZABCDE Where "Y" can be B, F, H, P, R, or Z; "Z" can be 0 or 4; "A" can be B,C,D,E,H,I,J,K,L,M, or N; "B" can be B or W; "C" can be A or C; "D" can be 3, 7, 8, or 9; and "E" can be 0, 1 or 2
Suniva	Suniva modules with 35, 38 and 40 mm frames OPTxxx-AA-B-YYY-Z MVXxxx-AA-B-YYY-Z Where "AA" is either 60 or 72; "B" is either 4 or 5; "YYY" is either 100,101,700,1B0, or 1B1; and "Z" is blank or B
Sunmac Solar	Sunmac Solar modules with 30 and 35mm frames SMxxxMaaaZZ-BB Where "aaa" can be 660 or 754; and "ZZ" can be NH or SH
Sunpower	Sunpower standard (G3 or G4) or InvisiMount (G5) 35 and 40mm frames SPR-Zb-xxx-YY Where "Z" can be A, E, M, P or X; "b" can be blank, 17, 18, 19, 20, 21, or 22; and "YY" can be blank, BLK, COM, C-AC, D-AC, E-AC, BLK-E-AC, G-AC, BLK-G-AC, H-AC, BLK-H-AC, BLK-C-AC, or BLK-D-AC
Sunspark	Sunspark modules with 40 mm frames SYY-xxxZ-A Where "YY" can be MX or ST; and "Z" can be M, MB, M3, M3B, P or W; and "A" can be 60 or 72
Suntech	Suntech Modules with 35 and 40mm frames STPxxxz-aa Where "y" is blank or S; and "zz" can be 20, 24, A60, A72U, B60 or B72; and "aa" can be Vd, Vem, Vfw, Vfh, Vnh, Wdb, Wde, Wd, Wfhh or Wnhb
Talesun	Talesun modules with 30, 35 and 40mm frames TAByZZaa-xxx-b Where "A" can be D or P; "B" can be 6 or 7; "y" can be blank, F, G, H, I or L; "ZZ" can be 60, 66, 72 or 78; "aa" can be M, M(H), or P; and "b" can be blank, B, T, or (H)



## MODULE COMPATIBILITY

Tesla	<p>Tesla modules with 40 mm frames TxxxY Where "Y" can be H or S</p>
Trina	<p>Trina Modules with 30, 35 and 40mm frames TSM-xxxYYZZ Where "YY" can be DD05, DD06, DD14, DE14, DE15, DE15V, DEG15, DEG15VC, DE18M, DEG18MC, DE09, DE19, DEG19C.20, DE06X, PA05, PC05, PD05, PD06, PA14, PC14, PD14, PE14, or PE15 ; and "ZZ" can be blank, .05, .05(II), .08, .08(II), .10, .18, .08D, .18D, 0.82, .002, .00S, 05S, 08S, .20(II), A, A.05, A.08, A.10, A.18, (II), A(II), A.05(II), A.08(II), A.082(II), A.10(II), A.18(II), C.05, C.07, C.05(II), C.07(II), H, H(II), H.05(II), H.08(II), HC.20(II), HC.20(II), M, M(II), M.05(II), MC.20(II)</p>
URE	<p>URE modules with 35 mm frames DyZxxxaa Where "D" can be D or F, "y" can be A, B, 6 or 7; "Z" can be K or M; and "aa" can be C8G, H3A, H4A, H8A, E7G-BB, E8G, E8G-BB or MFG-BB</p>
Vikram	<p>Vikram solar modules with 35 and 40 mm frames XVSyy.ZZ.AAA.bb Where "X" can be blank, Paradea, Prexos or Somera; "yy" can be M, P, MBB, MDH, MDHT, MH, MS, MHBB, or PBB; "ZZ" can be 60 or 72; "AAA" is the module power rating; and "bb" can be 03, 04 or 05</p>
VSUN	<p>VSUN modules with 30, 35 and 40 mm frames VSUNxxx-YYz-aa Where "YY" can be 60, 72, 108, 120, or 144; "z" can be M, P, MH, PH, or BMH; and "aa" can be blank, BB, BW, or DG</p>
Waaree	<p>Waaree modules with 40mm frames AAyy-xxx Where "AA" can be WS or Bi; and "yy" can be blank, M, MB, 55 or 66</p>
Winaico	<p>Winaico modules with 35 and 40 mm frames Wsy-xxxZa Where "y" can be either P or T; "Z" can be either M, P, or MX; and "a" can be blank or 6</p>
Yingli	<p>Yingli modules with 35 and 40 mm frames YLxxxZ-yy Where "Z" can be D or P; "yy" can be 29b, 30b, 34d, 35b, 36b or 40d</p>
ZN Shine	<p>ZN Shine modules with 35mm frames ZXMY-AAA-xxx/M Where "Y" can be 6, 7 or 8; "AAA" can be 72, NH120, NH144, NHDB144, NHLDD144, SH144, SHDB144, SHLDD144 or TP120</p>